

AGENDA

Midland Public Schools Vision Statement:

*Lead with respect, trust and courage.
Ensure an equitable, collaborative and inclusive culture. Enable all to achieve success.*

Regular monthly meetings are held at the Midland Public Schools Administration Center, 600 E. Carpenter Street, Midland, Michigan, at 7 p.m. with adjournment not later than 9:30 p.m. except by unanimous approval otherwise.

This meeting is a meeting of the Midland Public Schools' Board of Education in public for the purpose of conducting the School District's business and is not to be considered a public community meeting. There is a time for public participation during the meeting as indicated in the agenda. The Board of Education receives agenda material in advance of the meeting and has the opportunity to ask clarification questions of the staff. In order to expedite routine items of business and operations and maximize the opportunity for discussion topics, the Board will utilize a consent format for portions of the agenda as noted.

1. Call to Order

1. Roll Call

Board of Education:

Phillip Rausch, President
Scott McFarland, Vice President
Jennifer Ringgold, Secretary
Jonathan Lauderbach, Treasurer
Brad Blasy, Trustee
Meki Craig, Trustee
Ann Horowitz, Trustee

Central Staff:

Penny Miller-Nelson, Superintendent
Brian Brutyn, Assistant Superintendent
Kara Stark, Associate Superintendent of Student Services and Human Resources
Anna Wamack, Associate Superintendent of Finance, Facilities, and Operations
Kenneth Weaver, Associate Superintendent of Curriculum, Instruction, and Assessment

2. Requests to Address the Board Regarding Budget Workshop

Citizens are required to limit public comment to three minutes, except when this requirement is waived by the board president during the meeting. A designated timekeeper will communicate to the individual who is addressing the board at three



minutes. The Board of Education highly values public comment and input; however, the board meeting format is designed to facilitate the evening's agenda and, therefore, restricts board members from engaging in conversation with speakers or immediately responding to questions. Questions and concerns may be addressed by the board later in the agenda and may be assigned for follow-up by the board or superintendent at a later date.

To ensure due process and respect of individual rights, the District maintains a formal process for handling complaints against individuals. A problem involving an individual or specific incident is best handled through administrative channels. For assistance, please contact the superintendent's office.

Speakers are asked to express themselves in a civil manner, with due respect for the dignity and privacy of others who may be affected by the comments. While it is not the District's intent to stifle public comment, speakers should be aware that if statements violate the rights of others under the law of defamation or invasion of privacy, the speaker may be held legally responsible. If the speaker is unsure of the legal ramifications of what they are about to say, the District urges them to consult first with a legal advisor.

3. Board Discussion and Prioritization for 2026-2027 General Fund Budget

4. Consent Agenda

1. Approval of Minutes from the March 16, 2026 Regular Meeting 
2. Recommendations for Hire 

FTE	Assignment	New Hire
1.0	Special Education (Co-taught) Teacher at Midland High School	Andrew Filipek
1.0	Director of Fiscal Services	Hannah Kelly

3. Approval of Food Service Contract Renewal 

Administration recommends the renewal of the food service contract with Chartwells for the 2026-27 school year. This is the second renewal of the five-year contract.

4. Resignations 

The below staff announced their resignation effective these dates:

- Terry Borsum, Paraprofessional, Transportation, effective 03/09/2026
- Teresa Balzer, Bus Driver, Transportation, effective 03/25/2026
- Jennifer Hayward, Paraprofessional, Plymouth Elementary School, effective 03/26/2026
- Megan Sylvester, Paraprofessional, H.H. Dow High School, effective 04/09/2026
- Randi Meehle, Paraprofessional, Central Park Elementary School, effective

04/17/2026

- Haleigh Metiva, Paraprofessional, Chestnut Hill Elementary School, effective 04/17/2026
- Carolyn Bugard, Teacher, Adams Elementary School, effective 06/04/2026
- Jacquelyn Ellithorpe, Teacher, Adams Elementary School, effective 06/04/2026
- Paige Smith, Teacher, Adams Elementary School, effective 06/04/2026

5. Financials

Approval of the payment of the school system's bills for the month of February 2026 as listed in the check registers, prepared by Lori Holderby, in the total amount of \$9,590,572.00 is recommended. The distribution of obligations by fund is included in the documentation.

6. Legal Payments

Approval is requested to authorize legal payments to the below list for professional legal fees:

- Thrun Law Firm, P.C., for \$1,540.00, invoice number 312086, dated March 26, 2026
- Thrun Law Firm, P.C., for \$3,430.00, invoice number 312087, dated March 26, 2026
- Thrun Law Firm, P.C., for \$3,815.00, invoice number 312088, dated March 26, 2026
- Thrun Law Firm, P.C., for \$3,820.00, invoice number 312089, dated March 26, 2026

5. Board of Education Matters: Presentations to the Board

1. Shining Stars

Presenter: Superintendent Miller-Nelson

2. Spotlight on Excellence - Central Park Elementary

Presenter: Chelsea Sauve

3. Facility Planning Update (President Rausch)

4. Facility Planning Workshop

6. Requests to Address the Board

Citizens are required to limit public comment to three minutes, except when this requirement is waived by the board president during the meeting. A designated timekeeper will communicate to the individual who is addressing the board at three minutes. The Board of Education highly values public comment and input; however, the board meeting format is designed to facilitate the evening's agenda and, therefore,



restricts board members from engaging in conversation with speakers or immediately responding to questions. Questions and concerns may be addressed by the board later in the agenda and may be assigned for follow-up by the board or superintendent at a later date.

To ensure due process and respect of individual rights, the District maintains a formal process for handling complaints against individuals. A problem involving an individual or specific incident is best handled through administrative channels. For assistance, please contact the superintendent's office.

Speakers are asked to express themselves in a civil manner, with due respect for the dignity and privacy of others who may be affected by the comments. While it is not the District's intent to stifle public comment, speakers should be aware that if statements violate the rights of others under the law of defamation or invasion of privacy, the speaker may be held legally responsible. If the speaker is unsure of the legal ramifications of what they are about to say, the District urges them to consult first with a legal advisor.

7. Curriculum, Instruction, and Assessment

Study Committee Chair: Secretary Ringgold; Staff Resource Person: Associate Superintendent Weaver

1. Curriculum, Instruction, and Assessment Study Committee Meeting Notes from March 16, 2026 and April 8, 2026 
2. For Action: New School Program
3. For Information: Staff and Curriculum Development Proposals - Summary Proposals for Implementation in 2026-2027 School Year (Weaver) 

The district recommends 18 Staff & Curriculum Development Proposals for consideration. Following the 28-day period of public input, they will be presented for action at the May 18, 2026 Board of Education meeting. These proposals reflect the identified needs for curriculum and staff development and align with the continuous improvement process.

The proposals include:

1. MPS Resiliency \$210,106
2. Multi-Tiered System of Supports (MTSS) \$46,070
3. Engineering (CTE) \$296
4. Instructional Design (CTE) \$5,678
5. Development of Xello Assignments and Activities \$9,464
6. Elementary Professional Development \$21,904

7. Sheltered Instruction Observation Protocol (SIOP) \$36,181
8. Online Curriculum & Online Vendor Review Process \$9,925
9. Online Honors Curriculum Review \$1,893
10. NMS MICIP \$17,745
11. Secondary ELA \$12,954
12. Secondary Math \$13,309
13. Secondary Science \$15,067
14. Secondary Social Studies \$31,129
15. Disciplinary Literacy \$52,852
16. Artificial Intelligence (AI) \$11,830
17. Blended Learning \$3,549
18. Instructional Technology \$21,294

Staff Development Proposals grand total \$521,246

Anticipated amount from General Fund \$105,867 with remaining potentially from related grants.

Upon approval of these projects and subsequent approval of funding through the budget process, the district team will consult with those leading each project to make decisions about implementation.

4. For Information: Sex Education Curriculum Resource Adoption

8. Requests to Address the Board Regarding Public Hearing on Proposed Revisions to Instruction in Sex Education

9. Finance, Facilities and Operations

Study Committee Chair: Member Blasy; Staff Resource Person: Associate Superintendent Wamack

1. Finance, Facilities & Operations Study Committee Meeting Notes from April 7, 2026 

2. For Action: Dow High Walk-In Cooler (Wamack) 

Bids were solicited and a tabulation is provided for a walk-in cooler at Dow High. Administration recommends issuing a purchase order to Refrigeration and Mechanical Services of Greenville, MO for \$75,715. Food Service funds will be utilized for this purchase.

3. For Action: Trailer Mounted Cooler (Wamack) 

Bids were solicited and a tabulation is provided for a trailer mounted cooler for our food service department. Administration recommends issuing a purchase order to Spencer Trailers of Spencer, IN for \$56,795. Food Service funds will be utilized for this purchase.

4. For Action: Concrete Bid (Wamack) 

Bids were solicited and a tabulation is provided for concrete repair work within MPS. Areas receiving work include Adams, Central Park, Dow High, Plymouth, Jefferson, and Midland High. Administration recommends issuing a purchase order to Stafford Landscaping of Memphis, MI for \$94,412. Capital Improvement funds will be utilized for this purchase.

5. For Action: Fast Ice Camera Bid (Wamack) 

Administration recommends approving a purchase order to Mobile Communications America (MCA) of Troy, MI, for \$77,412.40 for video security equipment for the new facility at Fast Ice Drive. This equipment includes nine 270-degree and nine 360-degree multi-sensor cameras, twelve indoor IR dome cameras, eight outdoor dual-head cameras, and 38 Enterprise camera channel licenses. This will provide comprehensive video surveillance and safety monitoring throughout and around the building. The pricing provided by MCA was secured through the REMC bid, ensuring compliance with Board purchasing policy. The expenditure will be paid for through 31aa Mental Health & Safety Grant funds.

6. For Action: Gifts Totaling \$25,092.00 (Wamack) 

School	Donor	Purpose	Amount
Dow High	HH Dow High Sports Boosters	Installation of 8 Electrical Circuits	\$9,842.00
Dow High	HH Dow High Sports Boosters	Installation of Daktronics Equipment	\$9,250.00
Midland High/Dow High	Dodrothy O Minikel Business Education Endowment Fund	BPA/DECA	\$6,000.00

7. For Information: Gifts totaling \$24,210.39 (Wamack) 

School	Donor	Purpose	Amount
Dow High	HH Dow High Sports Boosters	Rebounder for Boys and Girls Lacrosse	\$3,851.50
Midland High	Midland High Baseball Parents	Support for MH Baseball Team Needs	\$2,440.00
Dow High	Megan Yezak	DHS Drama Spring Musical	\$2,000.00
Midland High	Gerstacker Innovator Mini-Grant	Support TKO Transportation	\$2,000.00
	Michigan Foundation for	Backpack Buddy Program	

Adams	Agriculture	- Nutritional Resources	\$2,000.00
Midland High	Swan Valley School District	Transportation to BPA Nationals	\$1,961.80
Jefferson	Gerstacker Innovator Mini-Grant	Support for Silent Sustained Reading Program	\$1,550.00
Midland High	Tuscola Technology Center	Transportation to BPA Nationals	\$1,038.60
Midland High	Sam Bernstein Law Firm	MHS Hockey	\$1,000.00
Jefferson	Hemlock Semiconductor	TechnoHuskies Team 10309	\$1,000.00
Jefferson	CommunityGives Youth Service Program	CyDogs FTC 10615	\$1,000.00
Jefferson	CommunityGives Youth Service Program	TechnoHuskies Team 10309	\$1,000.00
Jefferson	Velazco Grill LLC	CyDogs Team 10615	\$500.00
Central Park	Kellogg Youth Fund	Beyond the Brick Safe Artifact Transportation	\$500.00
Siebert	Kellogg Youth Fund	Kindergarten Trip to the Zoo	\$500.00
Adams	Midland Kiwanis Foundation	Mrs. Richards Kindergarten Classroom	\$498.45
Adams	American Heart Association	Support for Adams Physical Education Program	\$300.00
Jefferson	Jefferson Parent Advisory Committee	Art Club Field Trip to Detroit Institute of Art	\$300.00
Plymouth	Donald Pearson	In Memory of Jean Pearson	\$200.00
Midland High	Ludus Technologies Inc.	Orchestra, Band & Choir	\$150.02
Dow High	Ludus Technologies Inc.	Orchestra, Band & Choir	\$150.02
Central Park	Meki & Ian Craig	Central Park Robotics	\$100.00
Midland High	Dow Inc Political Action Committee	Robotics	\$65.00
Jefferson	Gavin & Lindsey McMacken	TechnoHuskies Team 10309	\$50.00
Dow High	Dow Parent Advisory Committee	Go Green, Drama & DECA	\$40.00

Dow High	Charities Aid Foundation America	FRC Team 2619	\$6.00
Dow High	Charities Aid Foundation America	FRC Team 2619	\$4.00
Dow High	Charities Aid Foundation America	FRC Team 2619	\$3.00
Dow High	Charities Aid Foundation America	FRC Team 2619	\$2.00

8. For Information: Gifts of Item 

School	Donor	Item(s)	Estimated Value
Midland High	Lee Industrial Contracting	Welding supplies: 8-pipe caps, 12-90s, 8-Ts, 6-12' sticks of black pipe, 6-ball valves (all Sch 40 black iron pipe)	\$2,000.00
Midland High	BOSTONtec	Sheet metal, hardware, and casters for Mobile Quench Tank	\$4,952.00

10. Human Resources

Study Committee Chair: Member Horowitz; Staff Resource Person: Associate Superintendent Stark

1. For Information: The Board and Staff extend their deepest sympathy to the following family: (Stark) 
 - The Board and Staff extend their deepest sympathy to the family of Beth Chapman, who passed away on April 5, 2026. Beth was employed as a paraprofessional in various locations throughout the district until her retirement in 2017, with 28 years of service. Following her retirement, she also served as a substitute paraprofessional from 2017-2019.

11. Correspondence From the Board of Education

1. Letters from the Board of Education to: 
 - Gerstacker Foundation c/o Midland County ESA
 - Ludus Technologies, Inc.
 - H.H. Dow High Sports Boosters (2)
 - Firehouse Subs - K&S Brothers, LLC
 - The Music Parents of Northeast
 - Apprecots
 - Joseph & Angelin Nokku
 - Todd & Mary Draves Family Donor Advised Fund (2)
 - Julie Johnston & Angela Kerr
 - Jefferson Music Parents

12. Scheduled Activities: For Information

All meetings are Regular and Special Meetings of the Board of Education and begin at 7:00 p.m. at the MPS Administration Center (600 E. Carpenter, Midland) unless otherwise noted:

- May 18, 2026
- June 15, 2026
- July 20, 2026
- August 17, 2026
- September 21, 2026
- October 19, 2026
- November 16, 2026
- December 21, 2026

13. Study Session Discussion

This portion of the agenda is utilized by the Board to introduce topics for future study, to discuss school district related matters, to complete professional association business and to relate items of interest. No action is taken during this time. Occasionally closed sessions are scheduled to discuss confidential personnel, negotiations or property matters.

1. Points of Clarification
2. Announcements from Superintendent Miller-Nelson

14. Adjournment

1. Call to Order

1. 1. Roll Call

Recommendation

Board of Education:

Phillip Rausch, President

Scott McFarland, Vice President

Jennifer Ringgold, Secretary

Jonathan Lauderbach, Treasurer

Brad Blasy, Trustee

Meki Craig, Trustee

Ann Horowitz, Trustee

Central Staff:

Penny Miller-Nelson, Superintendent

Brian Brutyn, Assistant Superintendent

Kara Stark, Associate Superintendent of Student Services and Human Resources

Anna Wamack, Associate Superintendent of Finance, Facilities, and Operations

Kenneth Weaver, Associate Superintendent of Curriculum, Instruction, and Assessment

2. Requests to Address the Board Regarding Budget Workshop

Recommendation

Citizens are required to limit public comment to three minutes, except when this requirement is waived by the board president during the meeting. A designated timekeeper will communicate to the individual who is addressing the board at three minutes. The Board of Education highly values public comment and input; however, the board meeting format is designed to facilitate the evening's agenda and, therefore, restricts board members from engaging in conversation with speakers or immediately responding to questions. Questions and concerns may be addressed by the board later in the agenda and may be assigned for follow-up by the board or superintendent at a later date.

To ensure due process and respect of individual rights, the District maintains a formal process for handling complaints against individuals. A problem involving an individual or specific incident is best handled through administrative channels. For assistance, please contact the superintendent's office.

Speakers are asked to express themselves in a civil manner, with due respect for the dignity and privacy of others who may be affected by the comments. While it is not the District's intent to stifle public comment, speakers should be aware that if statements violate the rights of others under the law of defamation or invasion of privacy, the speaker may be held legally responsible. If the speaker is unsure of the legal ramifications of what they are about to say, the District urges them to consult first with a legal advisor.

3. Board Discussion and Prioritization for 2026-2027 General Fund Budget

4. Consent Agenda

4. 1. Approval of Minutes from the March 16, 2026 Regular Meeting

Meeting Minutes

Board Meeting



[_03/16/2026 - Board of Education Meeting](#)

MEETING MINUTES

Midland Public Schools Vision Statement:

*Lead with respect, trust and courage.
Ensure an equitable, collaborative and inclusive culture. Enable all to achieve success.*

Regular monthly meetings are held at the Midland Public Schools Administration Center, 600 E. Carpenter Street, Midland, Michigan, at 7 p.m. with adjournment not later than 9:30 p.m. except by unanimous approval otherwise.

This meeting is a meeting of the Midland Public Schools' Board of Education in public for the purpose of conducting the School District's business and is not to be considered a public community meeting. There is a time for public participation during the meeting as indicated in the agenda. The Board of Education receives agenda material in advance of the meeting and has the opportunity to ask clarification questions of the staff. In order to expedite routine items of business and operations and maximize the opportunity for discussion topics, the Board will utilize a consent format for portions of the agenda as noted.

Attendance

Board of Education

Phillip Rausch, President
Scott McFarland, Vice President
Jennifer Ringgold, Secretary
Jon Lauderbach, Treasurer
Brad Blasy, Trustee
Meki Craig, Trustee
Ann Horowitz, Trustee

Central Staff

Penny Miller-Nelson, Superintendent
Brian Brutyn, Assistant Superintendent
Kara Stark, Associate Superintendent of Student Services and Human Resources
Anna Wamack, Associate Superintendent of Finance, Facilities, and Operations
Kenneth Weaver, Associate Superintendent of Curriculum, Instruction, and Assessment

1. Call to Order

1. Roll Call

2. Consent Agenda

Motion made by: Jon Lauderbach

Motion seconded by: Scott McFarland

Voting results: Unanimously Approved

1. Approval of Minutes from the February 16, 2026 Regular Meeting, February 16, 2026 Closed Session, and February 27, 2026 Special Meeting

2. Resignations

The below staff announced their resignation effective these dates:

- Kimberly Slater, Bus Driver, Transportation, effective 02/20/2026
- Beth Jankens, Paraprofessional, Plymouth Elementary School, effective 02/27/2026
- Rebecca Longoria, Teacher, Midland High School, effective 02/27/2026
- Kristine Fagersten, Paraprofessional, Siebert Elementary School, effective 03/06/2026
- Taylor Overzet, Paraprofessional, Central Park Elementary School, effective 03/27/2026
- Emily Urban, Teacher, Plymouth Elementary School, effective 06/03/2026

3. Financials

Approval of the payment of the school system's bills for the month of January 2026 as listed in the check registers, prepared by Lori Holderby, in the total amount of \$7,026,513.00 was recommended. The distribution of obligations by fund was included in the documentation.

4. Legal Payments

Approval was requested to authorize legal payments to the below list for professional legal fees:

- PDKST, for \$1,988.00, invoice number 63761, dated February 19, 2026
- Thrun Law Firm, P.C., for \$2,730.00, invoice number 311392, dated February 26, 2026
- Thrun Law Firm, P.C., for \$4,587.00, invoice number 311393, dated February 26, 2026

3. Board of Education Matters: Presentations to the Board

1. Shining Stars

Presenter: Superintendent Miller-Nelson

Congratulations to our March Shining Stars: Hilarie Huschke, Teacher - Northeast Middle School; and Paul Hoisington, Bus Driver - Transportation.

2. Spotlight on Excellence - Carpenter Pre-Primary Center

StoryMaking - presented by Melissa Ahearn, Laura DeShais, Amber Sanel, and Katrina Spry, who were accompanied by Pre-Primary students who also participated in the presentation.

3. George G. Mallinson Award from the Michigan Science Teachers Association

Presenter: Superintendent Miller-Nelson

Congratulations to Dr. Christie Gayheart, Science Teacher at Jefferson Middle School, on being named the recipient of the George G. Mallinson Award for Lifetime Achievement in the Field of Science Education from the Michigan Science Teachers Association (MSTA).

4. Strategic Planning Update (President Rausch)

President Rausch reminded the public that the district's strategic planning was designed to define our purpose, clarify our objectives, and build a strong foundation for future goal-setting. With the Board's foundational work now complete, the plan officially transitions to district leadership for implementation. We extend our sincere gratitude to the collaborative working teams - comprising Board members, district leadership, and community members - for their invaluable insights. As we shift from planning to action, your continued engagement will remain essential to our success.

5. For Action: Approval of Strategic Plan

Motion made by: Ann Horowitz

Motion seconded by: Scott McFarland

Voting results: Unanimously Approved

6. New School Program

Presenter: Lucas Peless

7. Facility Planning Update

Presenters: Steven Gunther, GMB; Kenny Babinski, Clark Construction; Kathie Fuce-Hobohm, Blueprint for Tomorrow Steering Team

4. Requests to Address the Board

Public comment/audience participation. No action was taken.

5. Curriculum, Instruction, and Assessment

1. Curriculum, Instruction, and Assessment Study Committee Meeting Notes from February 16, 2026 and March 3, 2026

Curriculum, Instruction, and Assessment Study Committee meeting notes from February 16, 2026 and March 3, 2026 were read aloud by Committee Chair Ringgold.

Curriculum, Instruction, Assessment (CIA) Study Committee Meeting Notes

Meeting Date: March 3, 2026

Members Present: Jennifer Ringgold, Chair; Ann Horowitz; Meki Craig; Ken Weaver; Penny Miller-Nelson; Anna Wamack

Guests Present: Steven Gunther, GMB; Bill Cox, Clark Construction

Meeting Location: MPS Administration Building, Conference Rooms C&D

The meeting started at 10:00 am.

Strategic Planning - The committee discussed district strategic planning.

Facilities Assessment - The committee discussed the facilities assessment.

The meeting adjourned at 11:15 am.

CIA Meetings are scheduled for the third Monday (Board Meeting Monday), 1:30-2:45.

Remaining CIA Meeting Dates 2025-26: March 16, April 20, and May 18

Curriculum, Instruction, Assessment (CIA) Study Committee Meeting Notes

Meeting Date: February 16, 2026

Members Present: Jennifer Ringgold, Chair; Ann Horowitz; Meki Craig; Ken Weaver; Penny Miller-Nelson

Guests Present: Nicole Bruski, Amanda Thoms, Yang (Joy) Jiao, Andrea Jozwiak

Meeting Location: Northeast Middle School

The meeting started at 1:30 pm.

1. The committee visited a band classroom and a choir classroom at Northeast Middle School.
2. Nicole Bruski and Amanda Thoms presented on the MPS music program.
3. Yang (Joy) Jiao presented on student and family engagement activities for January and February.

The meeting adjourned at 2:45 pm.

CIA Meetings are scheduled for the third Monday (Board Meeting Monday), 1:30-2:45.
Remaining CIA Meeting Dates 2025-26:
March 16, April 20 and May 18

6. Finance, Facilities and Operations

1. Finance, Facilities & Operations Study Committee Meeting Notes from March 2, 2026

Finance, Facilities & Operations Study Committee meeting notes from March 2, 2026 were read aloud by Committee Chair Blasy.

Finance, Facilities, & Operations Study Committee Meeting Notes

Meeting Date: March 2, 2026, 5:00 pm

Members Present: Brad Blasy, Chair; Scott McFarland, Penny Miller-Nelson, Anna Wamack

Guests Present: Steven Gunther and Gary Smith, GMB
Kevin Bouchey, Clark Construction

Meeting Location: MPS Administration Center, Room 9

The meeting started at 5:00 pm

January Financials - January financials were reviewed.

MCoNet Fiber - The committee discussed the potential use of MCoNet fiber.

Pool Resurfacing Bid - Administration will propose awarding a bid for resurfacing the pool at Dow High.

Mulch Bid - Administration will propose awarding a bid for pea stone removal and mulch installation at Chestnut Hill and Siebert.

Filter First Demo Bid - Administration will propose awarding a bid for required Filter First drinking fountain demolition.

Food Service Renewal - The committee discussed the process for renewing the food service management contract.

Audit Service Renewal - The committee discussed renewing audit services with Yeo and Yeo.

Fast Ice Update - The committee discussed the status of Fast Ice building renovations.

Alternative Programming - The committee discussed alternative programming.

Strategic Planning - The committee discussed district strategic planning.

Facilities Assessment - The committee discussed the facilities assessment.

The meeting adjourned at 6:36 pm

2. For Action: 2025-2026 Budget Amendment #1 (Wamack)

Motion made by: Scott McFarland

Motion seconded by: Jon Lauderbach

Voting results: Unanimously Approved

3. For Action: Pool Resurfacing Bid (Wamack)

Bids were solicited and a tabulation was provided for resurfacing the Midland Community Pool at Dow High. Administration recommended issuing a purchase order to Advanced Pool Systems Inc. of Highland, MI for \$163,025.00. Capital Improvement funds will be utilized for this purchase.

Motion made by: Scott McFarland

Motion seconded by: Jon Lauderbach

| **Voting results:** Unanimously Approved

4. For Action: Pea Stone Removal and Mulch Installation Bid (Wamack)

Bids were solicited, and a tabulation was provided for pea gravel removal and delivery and installation of mulch at Chestnut Hill and Siebert Elementary Schools. This project is being undertaken to comply with playground safety standards. Administration recommended issuing a purchase order to Three Oaks Groundcover of Wayland, MI, for \$97,846.00. Capital Improvement funds will be utilized for this purchase.

Motion made by: Jennifer Ringgold

Motion seconded by: Jon Lauderbach

| **Voting results:** Unanimously Approved

5. For Action: Filter First Drinking Fountain Demo Bid (Wamack)

Bids were solicited and a tabulation was provided for demolition of water fountains throughout the district to comply with Filter First legislation. Administration recommended issuing a purchase order to William E. Walter of Saginaw, MI for \$76,900.00. Filter First grant funds will be utilized for this purchase.

Motion made by: Scott McFarland

Motion seconded by: Jennifer Ringgold

| **Voting results:** Unanimously Approved

6. For Action: Gifts Totaling \$10,445.00 (Wamack)

School	Donor	Purpose	Amount
Dow High	HH Dow High Sports Boosters	Volleyball Net System	\$5,445.00
Dow High	Gerstacker Foundation c/o Midland County ESA	Purchase of Underwater Remotely Operated Vehicles	\$5,000.00

Motion made by: Jon Lauderbach

Motion seconded by: Ann Horowitz

| **Voting results:** Unanimously Approved

7. For Information: Gifts totaling \$10,371.44 (Wamack)

School	Donor	Purpose	Amount
Dow High	Todd & Mary Draves Family Donor Advised Fund	Student Leadership Conference Expenses	\$2,000.00
Jefferson	Jefferson Music Parents	Music Programs	\$2,000.00
Dow High	HH Dow High Sports Boosters	Boys Volleyball	\$1,000.00
Dow High	Julie Johnston & Angela Kerr	Boys Volleyball Uniforms	\$1,000.00
Midland High	Todd & Mary Draves Family Donor Advised Fund	Food Pantry	\$1,000.00
Dow High	CommunityGives Youth Service Program	DHS City Explorers Club	\$1,000.00
Jefferson	Joseph & Angelin Nokku	JMS TechnoHuskies	\$1,000.00
Midland High	Kellogg Youth Fund	Decision Day Celebrations	\$500.00
Dow High	Apprecots	DHS Drama Spring Musical	\$300.00
Northeast	Northeast Music Parents TMPONE	Support for Tuners for Orchestra	\$266.00
Dow High	Firehouse Subs - K&S Hoffman Brothers, LLC	DHS Softball	\$200.00
Jefferson	Ludus Technologies, Inc.	Drama Club	\$105.44

7. Correspondence From the Board of Education

1. Letters from the Board of Education to:

- Siebert Elementary PTO
- Jean Krause
- FIRST of the Great Lakes Bay Region (3)
- Adams Elementary PTO
- Central Park PTO
- Garber Chevrolet, Inc.
- United Dairy Industry of Michigan - Moolah for Schools Grant
- HH Dow High Sports Boosters
- MHS Athletic Boosters
- Barbara Morrison
- Tri-Star Trust
- Colin Buell
- Holocaust Memorial Center
- Geskus Photography
- Kiwassee Kiwanis
- Members First Credit Union

- Memorial Presbyterian Church
- Ludus Technologies, Inc.
- Stephanie Heyland, DMD, PLLC
- Charities Aid Foundation America

8. Scheduled Activities: For Information

All meetings are Regular and Special Meetings of the Board of Education and begin at 7:00 p.m. at the MPS Administration Center (600 E. Carpenter, Midland) unless otherwise noted:

- April 20, 2026
- May 18, 2026
- June 15, 2026
- July 20, 2026
- August 17, 2026
- September 21, 2026
- October 19, 2026
- November 16, 2026
- December 21, 2026

1. For Action: Motion to change the start time of the April 20, 2026 regular meeting to 6:00 pm

Motion made by: Jon Lauderbach

Motion seconded by: Scott McFarland

Voting results: Unanimously Approved

9. Study Session Discussion

1. Points of Clarification

President Rausch addressed proficiency, stating that the district's approach to serving all students includes prioritizing long-term outputs, as indicated in the MPS "Profile of a Graduate." Progressive growth is evident by increased proficiency in 11th - 12th grades. While district SAT scores consistently exceed state averages and are among the best in the state, he acknowledged a commitment to continuous improvement, with continued focus on the elementary level to further support student growth.

2. Announcements from Superintendent Miller-Nelson

Superintendent Miller-Nelson expressed excitement about bringing the new strategic plan and graduate profile to life with help from Omni Tech now that it has the Board's approval. Regular feedback will be provided to the Board about the progress.

We are also thrilled to introduce the SHINE Squad (Support, Help, Inspire, Nurture, and Engage)



- a fresh reboot of our district volunteer program. Our strategic planning sessions made one thing clear: our community wants deeper connections. The SHINE Squad offers a variety of meaningful ways to get involved and make a difference. Ready to shine with us? Visit the MPS website today to complete your application!

To wrap up, Trustee Horowitz shared a shout-out to the Midland High Girls Varsity Basketball team for their outstanding season. Congratulations to the Chemics on a job well done!

10. Adjournment

The meeting adjourned at 9:20 PM.

Motion made by: Jon Lauderbach

Motion seconded by: Jennifer Ringgold

Voting results: Unanimously Approved

DRAFT

4. 2. Recommendations for Hire

Recommendation

FTE	Assignment	New Hire
1.0	Special Education (Co-taught) Teacher at Midland High School	Andrew Filipek
1.0	Director of Fiscal Services	Hannah Kelly

Supporting Documents

 [New Hire Recommendation April 2026 \(1\)](#)

**SUPERINTENDENT'S RECOMMENDATION OF STAFF FOR EMPLOYMENT BY BOARD OF EDUCATION
SCHOOL DISTRICT OF MIDLAND, MICHIGAN**

Hires for the 2025-2026 School Year

<u>FTE</u>	<u>Assignment</u>	<u>New Hire</u>	<u>Education</u>	<u>University/College</u>
1	Special Education (Co-taught) Teacher at Midland High School	Andrew Filipek	MA	Saginaw Valley State University
1	Director of Fiscal Services	Hannah Kelly	BA	Olivet Nazarene University

Believing that the foregoing nominee is the best candidate among those whose credentials are complete in our files and that he/she is now available, I recommend his/her employment.

Superintendent

4. 3. Approval of Food Service Contract Renewal

Recommendation

Administration recommends the renewal of the food service contract with Chartwells for the 2026-27 school year. This is the second renewal of the five-year contract.

Supporting Documents



[.MDE approved renewal agreement - Midland](#)

School Year 2026-2027
Food Service Management Company
Contract Renewal Agreement
(COST REIMBURSABLE CONTRACT)

**Note: Do not complete this tab if sponsor has a Fixed Price contract.
Use the Fixed Price Agreement form on next tab.**

Sponsor Name			Agreement Number		
Midland Public Schools			56010		
Food Service Management Company Name			Year of Original Contract		
Compass Group USA, Inc. by and through its Chartwells Division			2024		
<p>This document contains the rates and fees for the furnishing of food service management for non-profit food service programs for the period beginning July 1, 2026, and ending June 30, 2027. The terms and conditions of the original contract are applicable to the contract renewal. The Consumer Price Index for All Urban Consumers (CPI-U) for the Midwest Region for December 2025 is 4% as released by the U.S. Bureau of Labor Statistics. The Equivalent Meal Factor increased from \$4.9700 to \$5.14 for SY 2025-2026.</p> <p>This Contract Renewal Agreement, attachments, and the original Contract, with addenda, if any, constitute the entire agreement between the Sponsor and the Food Service Management Company. The parties shall not execute any additional contractual documents pertaining to this Contract, except as permitted by applicable law.</p>					
RATES MUST NOT BE ROUNDED UP					
Fee Items	Current SY 25-26 Rate (must match what was approved by MDE for the SY 25-26 renewal)	Percentage Rate of Increase		New SY 26-27 Rate**	Note:
		% Per Original Contract	Other Agreed Upon % for SY 26-27*		
1. Management Fee per Meal (breakfast and lunch) and Meal Equivalent (a la carte)	\$ 0.0618	3.0%		\$ 0.0636	<p>*Only percentage rates lower than the original contract's percentage rate may be negotiated and/or agreed upon by both parties (such as 0%) for renewals. Higher negotiated percentage rates are not allowed; a rebid for new contract terms will be necessary.</p> <p>**Price Per Meal and Meal Equivalents must be quoted as if no USDA Donated Commodities will be received.</p> <p>***Planned Client Investment refers to any planned dollar amount the FSMC will invest on the Sponsor's behalf to improve the food service program (such as the purchase of large kitchen equipment or improvements to serving lines, etc.). The Sponsor will pay back that dollar amount to the FSMC over a specified time period as agreed upon by both parties.</p>
2. Administrative Fee per Meal or Month	\$ 15,347.00	3.0%		\$ 15,807.41	
3. Reimbursable Breakfasts	N/A	N/A	N/A	N/A	
4. Reimbursable Lunches	N/A	N/A	N/A	N/A	
5. A la Carte Meal Equivalents	N/A	N/A	N/A	N/A	
6. After School Snacks	N/A	N/A	N/A	N/A	
7. At Risk Suppers	N/A	N/A	N/A	N/A	
8. Special Milk	N/A	N/A	N/A	N/A	
9. Has the SY 26-27 budget been agreed upon by the Sponsor and FSMC? (yes/no)		NO			
10. Advance Payment dollar amount for SY 26-27, if any		\$ N/A			
11. Guaranteed Return dollar amount for SY 26-27, if any		N/A			
12. Planned Client Investment*** dollar amount for SY 26-27, if any		N/A			
13. Has the Sponsor made any changes to the scope of service in the last year?			Describe Changes Made in the Last Year		Addendum or Amendment Approved by MDE (yes/no)
<input checked="" type="checkbox"/> Mark all that apply.					
<input type="checkbox"/> Added or closed a site(s)					
<input type="checkbox"/> Began a new child nutrition program, such as CACFP, SFSP, FFVP, etc.					
<input type="checkbox"/> Made changes to meal types served, such as adding snacks or suppers					
<input type="checkbox"/> Added a vended meal agreement/contract with another sponsor					
<input type="checkbox"/> Added an alternate agreement with another local education authority (LEA)					
<input type="checkbox"/> Made changes to revenue, such as catering, concessions, vending machines, etc.					
<input type="checkbox"/> Other (describe)					
Before MDE Approval - Both parties must sign this portion prior to GEMS/MARS upload.			After MDE Approval		
<p>The Food Service Management Company (FSMC) certifies that it will operate in accordance with all applicable State and Federal laws and regulations. By submission of this proposal, the FSMC certifies that, in the event it receives a renewal award under this solicitation, the FSMC shall operate in accordance with applicable program laws and regulations. The FSMC shall not plead misunderstanding or deception because of such estimates of quantities, or of the character, location, or other conditions pertaining to the proposal. This Agreement shall not exceed one year.</p> <p>IN WITNESS WHEREOF, both parties agree to the terms specified on this Contract Renewal Agreement and hereto have caused this Agreement to be signed by their duly authorized representative on this day and year.</p>			FOR MDE USE ONLY		
			Michigan Department of Education (MDE) has reviewed and approved this Food Service Management Company Contract Renewal Agreement for School Year 2026-2027.		
			MDE Reviewer Signature		Date Approved
			<i>Tammy Saul</i>		<i>3/6/26</i>
			Sponsor must sign this section AFTER MDE's review/approval in GEMS/MARS.		
<p>The Sponsor may proceed with this item at the next board meeting for approval and obtain the authorized Board Representative signature and date below. Once the contract renewal is fully executed, it is the Sponsor's responsibility to upload a copy of the final, fully executed FSMC Contract Renewal Agreement form into GEMS/MARS and submit a copy to the FSMC.</p>					
FSMC's Authorized Representative Signature		Date			
<i>Amy Shaffer</i>		<i>2/26/2026</i>			
Printed Name/Title					
Amy Shaffer CEO, Chartwells K12					
Sponsor's Authorized Representative Signature		Date		Sponsor's Board Representative Signature	
<i>Anna Wasmack</i>		<i>2/27/26</i>		<i>Anna Wasmack</i>	
Printed Name/Title				Printed Name/Title	
Anna Wasmack Assoc. Superintendent				Anna Wasmack	

4. 4. Resignations

Recommendation

The below staff announced their resignation effective these dates:

- Terry Borsum, Paraprofessional, Transportation, effective 03/09/2026
- Teresa Balzer, Bus Driver, Transportation, effective 03/25/2026
- Jennifer Hayward, Paraprofessional, Plymouth Elementary School, effective 03/26/2026
- Megan Sylvester, Paraprofessional, H.H. Dow High School, effective 04/09/2026
- Randi Meehle, Paraprofessional, Central Park Elementary School, effective 04/17/2026
- Haleigh Metiva, Paraprofessional, Chestnut Hill Elementary School, effective 04/17/2026
- Carolyn Bugard, Teacher, Adams Elementary School, effective 06/04/2026
- Jacquelyn Ellithorpe, Teacher, Adams Elementary School, effective 06/04/2026
- Paige Smith, Teacher, Adams Elementary School, effective 06/04/2026

Supporting Documents



[_BOE Retirements and Resignations April](#)









April 2026 Announced Resignations

Employee Name	Title	Location	Effective Date
Meehle, Randi	Paraprofessional	Central Park	4/17/2026
Sylvester, Megan	Paraprofessional	H.H. Dow High School	4/9/2026
Smith, Paige	Teacher	Adams	6/4/2026
Balzer, Teresa	Bus Driver	Transportation	3/25/2026
Burgard, Carolyn	Teacher	Adams	6/4/2026
Borsum, Terry	Paraprofessional	Transportation	3/9/2026
Ellithorpe, Jacquelyn	Teacher	Adams	6/4/2026
Hayward, Jennifer	Paraprofessional	Plymouth	3/26/2026
Metiva, Haleigh	Paraprofessional	Chestnut Hill	4/10/2026

Recommendation

Approval of the payment of the school system's bills for the month of February 2026 as listed in the check registers, prepared by Lori Holderby, in the total amount of \$9,590,572.00 is recommended. The distribution of obligations by fund is included in the documentation.

Supporting Documents

-  [_Combined Feb 2026 PO & PC Support](#)
-  [_February 2026 dashboard](#)
-  [_February 25-26 General Fund Revenue by Source](#)
-  [_February 25-26 General Fund Expenses by Object](#)
-  [_February 25-26 General Fund Expenses by Function](#)
-  [_February 25-26 dashboard board](#)
-  [_February 25-26 dashboard board obligations](#)
-  [_25-26 February Expense Graph](#)

Midland Public Schools

600 E Carpenter St
Midland, MI 48640

PURCHASE ORDER NO. 260785

PAGE NO. 1

VENDOR 110853
METRO ELEVATOR MICHIGAN INC
100 WEST BIG BEAVER ROAD
SUITE 200
TROY MI 48084

SHIP TO
MAINTENANCE DEPARTMENT
MIDLAND PUBLIC SCHOOLS
811 GEORGE STREET
MIDLAND MI 48640
ATTN: MICHAEL MOEGGENBERG

ORDER DATE: 02/10/26		BUYER: MICHAEL MOEGGENBERG		REQ. NO.: 2601123	REQ. DATE:
TERMS: NET 30 DAYS		F.O.B.:		DESC.:	
ITEM	QUANTITY	UOM	DESCRIPTION	UNIT PRICE	EXTENSION
01	1.00		MHS- REPLACE HYDRAULIC CYLINDER, PLUS DRILL WELL FOR NEW CYLINDER IS NEEDED	159160.3400	159,160.34
02	1.00		CENTRAL AUDITORIUM- REPLACE HYDRAULIC CYLINDER, PLUS DRILL WELL FOR NEW CYLINDER IS NEEDED	131049.2000	131,049.20
ITEM	ACCOUNT		AMOUNT	PROJECT CODE	PAGE TOTAL \$ 290,209.54
01	414560000000 6220		159,160.34		TOTAL \$ 290,209.54
02	414560000000 6220		131,049.20		

SEND INVOICE TO:
Midland Public Schools
Accounts Payable
600 E. Carpenter St.
Midland, MI 48640

PURCHASING AUTHORIZATION

Midland Public Schools

600 E Carpenter St
Midland, MI 48640

PURCHASE ORDER NO.260830

PAGE NO. 1

VENDOR 110869
PRIME RESULTS LLC
235 TAWAS ST A
ALPENA MI 49707

SHIP TO MAINTENANCE DEPARTMENT
MIDLAND PUBLIC SCHOOLS
811 GEORGE STREET
MIDLAND MI 48640
ATTN: MICHAEL MOEGGENBERG

ORDER DATE: 02/26/26		BUYER: MICHAEL MOEGGENBERG		REQ. NO.: 2601190	REQ. DATE:
TERMS: NET 30 DAYS		F.O.B.:		DESC.:	
ITEM	QUANTITY	UOM	DESCRIPTION	UNIT PRICE	EXTENSION
01	1.00		DISTRICT- CLEAN, PREP, CRACK FILL, SEALCOAT AND LINE PAINT	92401.0000	92,401.00
ITEM		ACCOUNT		AMOUNT	PROJECT CODE
				PAGE TOTAL \$	92,401.00
01	414520000000	6220	92,401.00	TOTAL \$	92,401.00
SEND INVOICE TO: Midland Public Schools Accounts Payable 600 E. Carpenter St. Midland, MI 48640					

PURCHASING AUTHORIZATION

Midland Public Schools

600 E Carpenter St
Midland, MI 48640

PURCHASE ORDER NO. 260839

PAGE NO. 1

VENDOR 110139
LUNGHAMER FORD OF OWOSSO LLC
1960 E MAIN ST
OWOSSO MI 48867

SHIP TO MAINTENANCE DEPARTMENT
MIDLAND PUBLIC SCHOOLS
811 GEORGE STREET
MIDLAND MI 48640
ATTN: MICHAEL MOEGGENBERG

ORDER DATE: 02/26/26		BUYER: MICHAEL MOEGGENBERG		REQ. NO.: 2601202	REQ. DATE:
TERMS: NET 30 DAYS		F.O.B.:		DESC.:	
ITEM	QUANTITY	UOM	DESCRIPTION	UNIT PRICE	EXTENSION
01	2.00		FOOD SERVICE-2027 FORD E450 CUTAWAY VAN WITH 16' ALUMINUM VAN BODY	67859.0000	135,718.00
			PAGE TOTAL \$ 135,718.00		
			TOTAL \$ 135,718.00		
ITEM	ACCOUNT	AMOUNT	PROJECT CODE	SEND INVOICE TO: Midland Public Schools Accounts Payable 600 E. Carpenter St. Midland, MI 48640	
01	252970000690 6410	135,718.00			

PURCHASING AUTHORIZATION

Midland Public Schools

600 E Carpenter St
Midland, MI 48640

PURCHASE ORDER NO. 260840

PAGE NO. 1

VENDOR
109235
SAMSARA NETWORKS INC.
444 DE HARO ST
SUITE 101
SAN FRANCISCO CA 94107

SHIP TO
MAINTENANCE DEPARTMENT
MIDLAND PUBLIC SCHOOLS
811 GEORGE STREET
MIDLAND MI 48640
ATTN: MICHAEL MOEGGENBERG

ORDER DATE: 02/26/26		BUYER: MICHAEL MOEGGENBERG		REQ. NO.: 2601203	REQ. DATE:
TERMS: NET 30 DAYS		F.O.B.:		DESC.:	
ITEM	QUANTITY	UOM	DESCRIPTION	UNIT PRICE	EXTENSION
01	1.00		TRANSPORTATION- LICENSES TO COVER: VEHICLE GATEWAYS, CAMERAS, FLEET TRACKING SERVICE AND SOFTWARE UPGRADES. TICKET 25885902, YEAR 1 OF 3. DUE 4-24-26 NET 90	52975.5300	52,975.53
ITEM	ACCOUNT		AMOUNT	PROJECT CODE	PAGE TOTAL \$ 52,975.53
01	112710000000	3450	52,975.53		TOTAL \$ 52,975.53
					SEND INVOICE TO: Midland Public Schools Accounts Payable 600 E. Carpenter St. Midland, MI 48640

PURCHASING AUTHORIZATION

1

Supply Chain Notice: We expect OEM cost increases and supply constraints due to demand in the memory and storage industries. Contact our specialists to secure inventory and pricing. [Learn More](#)

11-284-000-0000-3450
January 1, 2026 to December 31, 2026
Paid with S. Follen CC 1/5/26

Invoice#: AH5EA2G

Due
2/4/2026

cc
Sherrie Allen
1/5/26

Invoice Amount
\$91,781.91

Invoice Date 1/5/2026	Payment Terms MasterCard/Visa Govt	Customer # 0645598
Order # 1CJ458Z	Order Date 10/16/2025	PO # SHERRIE ALLEN/DAVE DZIEDZIC

Account Manager
Wes Farrell
847-419-8255
wesfar@cdw.com

Need help? Email Us
credit@cdw.com

PREPAY

January 1, 2026 to December 31, 2026

How to Pay

Electronic (ACH)

The Northern Trust
50 S. LaSalle St.
Chicago, IL 60675

Routing No.: 071000152
Account Name: CDW
GOVERNMENT LLC
Account No. 91057

E-mail Remittance To:
gachremittance@cdw.com

By Mail (Check)

CDW Government
75 Remittance Dr., Suite 1515
Chicago, IL 60675-1515

Shipping Information

Address of Use
DAVE DZIEDZIC
600 E CARPENTER ST

MIDLAND, MI, 48640-5417

Shipping Method
Digital Delivery

Attention to
DAVE DZIEDZIC

Billing Information

Billing Address

MIDLAND PUBLIC SCHOOLS
MIDLAND PUBLIC

600 E CARPENTER ST
OFFICE OF BUSINESS
MANAGEMENT
MIDLAND, MI, 48640-5417
989-923-5115

CDW PART #	DESCRIPTION	QUANTITY ORD / SHP / B.O	ITEM PRICE	ITEM TOTAL
5419420	Microsoft 365 A3 - subscription license - 1 user MFG # AAD-38391-12MO Contract # REMC SOFTWARE 2024	1130 1130 0	\$56.27	\$63,585.10
5419376	Microsoft 365 A3 - subscription license - 1 user MFG # AAD-38397-B-12mo Contract # MARKET	15000 15000 0	\$0.00	\$0.00
5680005	Microsoft Office 365 ProPlus Add-on - subscription license - 1 device MFG # RQL-00001-12MO Contract # MARKET	64 64 0	\$0.00	\$0.00

CDW PART #	DESCRIPTION	QUANTITY ORD / SHP / B.O	ITEM PRICE	ITEM TOTAL
4325198	Microsoft Windows Server Datacenter Edition - license & software assurance MFG # 9EA-00039 Contract # REMC SOFTWARE 2024	88 88 0	\$43.55	\$3,832.40
2379801	Microsoft Windows Server - External Connector License & Software Assurance MFG # R39-00374 Contract # REMC SOFTWARE 2024	5 5 0	\$190.62	\$953.10
2670095	Microsoft SQL Server Enterprise Core Edition License & Software Assurance MFG # 7JQ-00341 Contract # REMC SOFTWARE 2024	16 16 0	\$1,327.00	\$21,232.00
5419426	Microsoft 365 A5 - subscription license - 1 user MFG # AAD-38400-12MO Contract # REMC SOFTWARE 2024	7 7 0	\$117.69	\$823.83
3821974	Microsoft Visual Studio Enterprise with MSDN - license & software assurance MFG # MX3-00115 Contract # REMC SOFTWARE 2024	4 4 0	\$338.87	\$1,355.48
ISO 9001 and ISO 14001 Certified CDW DIRECT FEIN 36-4230110			Subtotal	\$91,781.91
			Shipping	\$0.00
			Tax	\$0.00
			Invoice Amount	\$91,781.91
			AMOUNT DUE	\$91,781.91



City of Midland
 PO Box 1647
 Midland, MI 48641-1647
 www.cityofmidlandmi.gov
 Phone: (989) 837-3315

Date: 01/20/2026
 Receipt: 2026-00054403
 Cashier: Treasurer 2
 Received From: MPS-Central Park
 Description: Elementary

WATER BILL	2,005.66
Account #: 11020-001	
Address: 1400 Rodd ST	
WATER BILL	725.13
Account #: 0033894-001	
Address: 305 E Reardon ST	
WATER BILL	1,807.58
Account #: 103-001	
Address: 1005 Adams DR	
WATER BILL	1,324.98
Account #: 2634-001	
Address: 1407 W Carpenter ST	
WATER BILL	1,998.08
Account #: 2928-001	
Address: 3900 Chestnut Hill DR	
WATER BILL	3,421.13
Account #: 11646-001	
Address: 3901 N Saginaw RD	
WATER BILL	3,368.62
Account #: 20919-001	
Address: 3901 N Saginaw RD Wa 2	
WATER BILL	2,790.77
Account #: 20940-001	
Address: 1301 Eastlawn DR Wa 2	
WATER BILL	2,568.52
Account #: 20941-001	
Address: 1301 Eastlawn DR Wa 3	
WATER BILL	113.65
Account #: 17421-002	
Address: 2600 Washington ST	
WATER BILL	680.34
Account #: 20925-002	
Address: 2600 Washington ST Wa 2	
WATER BILL	2,524.07
Account #: 4326-001	
Address: 1301 Eastlawn DR	
WATER BILL	639.18
Account #: 17090-002	
Address: 2620 Washington ST	
WATER BILL	2,496.78
Account #: 17458-001	
Address: 800 W Chapel LN	
WATER BILL	4,260.82
Account #: 13163-001	
Address: 1305 E Sugnet RD	
WATER BILL	2,191.98
Account #: 13143-001	
Address: 1105 E Sugnet RD	
WATER BILL	2,252.08
Account #: 12262-001	
Address: 5700 Siebert ST	
WATER BILL	927.71
Account #: 2579-001	
Address: 600 E Carpenter ST	
WATER BILL	308.98
Account #: 6622-001	
Address: 406 E Hines ST	
WATER BILL	461.49
Account #: 5198-001	
Address: 805 George ST	
WATER BILL	315.33
Account #: 6560-001	
Address: 411 E Hines ST	
WATER BILL	1,794.88
Account #: 4215-001	
Address: 5500 Drake ST	

Receipt Total	38,977.76
Total Charge	38,977.76
Total Remitted	38,977.76
Total Received	38,977.76

Customer Copy

CITY OF MIDLAND TREAS
 333 W ELLSWORTH STREET
 MIDLAND, MI 486400000

01/20/2026 08:25:40
 CREDIT CARD
 MC SALE

Card # XXXXXXXXXXXXX2976
 Chip Card: MASTERCARD
 AID: A0000000041010
 SEQ #: 1
 Batch #: 1296
 INVOICE: 1
 Approval Code: 000161
 Entry Method: Chip Read
 Mode: Issuer
 Tax Amount: \$0.00
 Cust Code:

SALE AMOUNT \$38977.76

5

CUSTOMER COPY

KML
 1/20/26

Checks Payable to **CITY OF MIDLAND**

P.O. BOX 1647 - MIDLAND, MI 48641-1647 (989) 837-3341

FIRST-CLASS MAIL
U.S. POSTAGE PAID
PERMIT NO. 5
MIDLAND, MI 48640

ACCOUNT NUMBER **11020-001** CYCLE **03** BILL DATE **12/22/2025**

SERVICE ADDRESS **1400 Rodd ST**
SERVICE PERIOD **9/1/2025 - 11/30/2025** # OF DAYS **95**

Service	Curr Read	Read Type	Usage (TGAL)
073289705	2,520.0	Manual Estimate	60
073289844	2,585.0	Manual Estimate	60

Cityofmidlandmi.gov/pay

1002-83

Description of Charges	AMOUNT
Sewer Usage	428.40
Sewer Readiness-To-Serve	685.08
Water Usage	333.60
Water Readiness-To-Serve	517.08
FP <= 6"	41.50

TOTAL CURRENT CHARGES	2,005.66
PREVIOUS BALANCE	0.00
TOTAL DUE	2,005.66

DUE DATE

Pay 2,206.23 After 1/22/2026

Checks Payable to **CITY OF MIDLAND**

P.O. BOX 1647 - MIDLAND, MI 48641-1647 (989) 837-3341

FIRST-CLASS MAIL
U.S. POSTAGE PAID
PERMIT NO. 5
MIDLAND, MI 48640

ACCOUNT NUMBER

0033894-001

CYCLE

03

BILL DATE

12/22/2025

SERVICE ADDRESS

305 E Reardon ST

SERVICE PERIOD

9/1/2025 - 11/30/2025

OF DAYS

98

Cityofmidlandmi.gov/pay

Service

082595620

Curr Read

767.0

Read Type

Routine

Usage (TGAL)

13

Description of Charges

Sewer Usage

Sewer Readiness-To-Serve

Water Usage

Water Readiness-To-Serve

FP <= 6"

AMOUNT

46.41

342.54

36.14

258.54

41.50

TOTAL CURRENT CHARGES

725.13

PREVIOUS BALANCE

0.00

TOTAL DUE

725.13

DUE DATE

Pay 797.65 After 1/22/2026

Checks Payable to CITY OF MIDLAND

P.O. BOX 1647 - MIDLAND, MI 48641-1647 (989) 837-3341

FIRST-CLASS MAIL
U.S. POSTAGE PAID
PERMIT NO. 5
MIDLAND, MI 48640

ACCOUNT NUMBER: 103-001
CYCLE: 03
BILL DATE: 12/22/2025

SERVICE ADDRESS: 1005 Adams DR
SERVICE PERIOD: 9/1/2025 - 11/30/2025
OF DAYS: 98

Cityofmidlandmi.gov/pay

Service	Curr Read	Read Type	Usage (TGAL)
090020260	2,173.0	Routine	190

Description of Charges	AMOUNT
Sewer Usage	678.30
Sewer Readiness-To-Serve	342.54
Water Usage	528.20
Water Readiness-To-Serve	258.54

TOTAL CURRENT CHARGES	1,807.54
PREVIOUS BALANCE	0.00
TOTAL DUE	1,807.54

DUE DATE

Pay 1,988.33 After 1/22/2026

Checks Payable to **CITY OF MIDLAND**

P.O. BOX 1647 - MIDLAND, MI 48641-1647 (989) 837-3341

FIRST-CLASS MAIL
U.S. POSTAGE PAID
PERMIT NO. 5
MIDLAND, MI 48640

ACCOUNT NUMBER

2634-001

CYCLE

03

BILL DATE

12/22/2025

SERVICE ADDRESS

1407 W Carpenter ST

SERVICE PERIOD

9/1/2025 - 11/30/2025

OF DAYS

97

Service

010183563

Curr Read

7,047.0

Read Type

Routine

Usage (TGAL)

114

Description of Charges

Sewer Usage

Sewer Readiness-To-Serve

Water Usage

Water Readiness-To-Serve

AMOUNT

406.98

342.54

316.92

258.54

Cityofmidlandmi.gov/pay

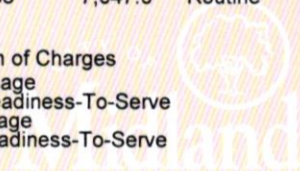

TOTAL CURRENT CHARGES

1,324.9

PREVIOUS BALANCE

0.00

TOTAL DUE

1,324.9

DUE DATE

Pay 1,457.48 After 1/22/2026

Checks Payable to **CITY OF MIDLAND**

P.O. BOX 1647 - MIDLAND, MI 48641-1647 (989) 837-3341

FIRST-CLASS MAIL
U.S. POSTAGE PAID
PERMIT NO. 5
MIDLAND, MI 48640

ACCOUNT NUMBER **2928-001** CYCLE **03** BILL DATE **12/22/2025**

SERVICE ADDRESS **3900 Chestnut Hill DR**

SERVICE PERIOD **9/1/2025 - 11/30/2025** # OF DAYS **97**

Cityofmidlandmi.gov/pay

Service **090020275** Curr Read **2,191.0** Read Type **Routine** Usage (TGAL) **220**

Description of Charges	AMOUNT
Sewer Usage	785.40
Sewer Readiness-To-Serve	342.54
Water Usage	611.60
Water Readiness-To-Serve	258.54

TOTAL CURRENT CHARGES	1,998.08
PREVIOUS BALANCE	0.00
TOTAL DUE	1,998.08
DUE DATE	

Pay 2,197.88 After 1/22/2026

Checks Payable to **CITY OF MIDLAND**

P.O. BOX 1647 - MIDLAND, MI 48641-1647 (989) 837-3341

FIRST-CLASS MAIL
U.S. POSTAGE PAID
PERMIT NO. 5
MIDLAND, MI 48640

ACCOUNT NUMBER **11646-001** CYCLE **03** BILL DATE **12/22/2025**

SERVICE ADDRESS
3901 N Saginaw RD

Service	Curr Read	Read Type	Usage (TGAL)
014206476	6,535.0	Routine	246
063540841	7,506.0	Routine	119

SERVICE PERIOD **9/1/2025 - 11/30/2025** # OF DAYS **101**

Cityofmidlandmi.gov/pay

Description of Charges	AMOUNT
Sewer Usage	878.22
Sewer Readiness-To-Serve	685.72
Water Usage	683.88
Water Readiness-To-Serve	517.55
Irrigation	330.82
Irrigation Readiness-To-Serve	258.54
FP > 6"	66.40

TOTAL CURRENT CHARGES	3,421.1
PREVIOUS BALANCE	0.00
TOTAL DUE	3,421.1

DUE DATE

Pay 3,763.24 After 1/22/2026

Checks Payable to **CITY OF MIDLAND**

P.O. BOX 1647 - MIDLAND, MI 48641-1647 (989) 837-3341

FIRST-CLASS MAIL
U.S. POSTAGE PAID
PERMIT NO. 5
MIDLAND, MI 48640

ACCOUNT NUMBER

20919-001

CYCLE

03

BILL DATE

12/22/2025

SERVICE ADDRESS

3901 N Saginaw RD Wa 2

SERVICE PERIOD

9/1/2025 - 11/30/2025

OF DAYS

101

Service

014250990

Curr Read

1,982.0

Read Type

Routine

Usage (TGAL)

341

Description of Charges

Sewer Usage

Sewer Readiness-To-Serve

Water Usage

Water Readiness-To-Serve

AMOUNT

1,217.3

685.72

947.98

517.55

Cityofmidlandmi.gov/pay

TOTAL CURRENT CHARGES

3,368.6

PREVIOUS BALANCE

0.00

TOTAL DUE

3,368.6

DUE DATE

Pay 3,705.48 After 1/22/2026

Checks Payable to **CITY OF MIDLAND**

P.O. BOX 1647 - MIDLAND, MI 48641-1647 (989) 837-3341

FIRST-CLASS MAIL
U.S. POSTAGE PAID
PERMIT NO. 5
MIDLAND, MI 48640

ACCOUNT NUMBER 20940-001 **CYCLE** 03 **BILL DATE** 12/22/2025

SERVICE ADDRESS
1301 Eastlawn DR Wa 2

SERVICE PERIOD 9/1/2025 - 11/30/2025 **# OF DAYS** 99

Cityofmidlandmi.gov/pay

Service 014232664 **Curr Read** 4,192.0 **Read Type** Routine **Usage (TGAL)** 250

Description of Charges	AMOUNT
Sewer Usage	892.50
Sewer Readiness-To-Serve	685.72
Water Usage	695.00
Water Readiness-To-Serve	517.55

TOTAL CURRENT CHARGES	2,790.7
PREVIOUS BALANCE	0.00
TOTAL DUE	2,790.7
DUE DATE	

Pay 3,069.85 After 1/22/2026

Checks Payable to **CITY OF MIDLAND**

P.O. BOX 1647 - MIDLAND, MI 48641-1647 (989) 837-3341

FIRST-CLASS MAIL
U.S. POSTAGE PAID
PERMIT NO. 5
MIDLAND, MI 48640

ACCOUNT NUMBER

CYCLE

BILL DATE

20941-001

03

12/22/2025

SERVICE ADDRESS

1301 Eastlawn DR Wa 3

Service

Curr Read

Read Type

Usage (TGAL)

014232380

1,628.0

Routine

215

SERVICE PERIOD

OF DAYS

9/1/2025 - 11/30/2025

99

Description of Charges

AMOUNT

Sewer Usage

767.55

Sewer Readiness-To-Serve

685.72

Water Usage

597.70

Water Readiness-To-Serve

517.55

Cityofmidlandmi.gov/pay

TOTAL CURRENT CHARGES

2,568.5

PREVIOUS BALANCE

0.00

TOTAL DUE

2,568.5

DUE DATE

Pay 2,825.38 After 1/22/2026

Checks Payable to **CITY OF MIDLAND**
P.O. BOX 1647 - MIDLAND, MI 48641-1647 (989) 837-3341

FIRST-CLASS MAIL
U.S. POSTAGE PAID
PERMIT NO. 5
MIDLAND, MI 48640

ACCOUNT NUMBER CYCLE BILL DATE
17421-002 **03** **12/22/2025**

SERVICE ADDRESS
2600 Washington ST
SERVICE PERIOD # OF DAYS
9/1/2025 - 11/30/2025 **71**

Service Curr Read Read Type Usage (TGAL)
065030836 **30.0** **Removal** **2**

Cityofmidlandmi.gov/pay

Description of Charges	AMOUNT
Sewer Usage	7.14
Sewer Readiness-To-Serve	57.12
Water Usage	5.56
Water Readiness-To-Serve	43.83

TOTAL CURRENT CHARGES

113.65

PREVIOUS BALANCE

0.00

TOTAL DUE

113.65

DUE DATE

Pay 125.02 After 1/22/2026

Checks Payable to **CITY OF MIDLAND**

P.O. BOX 1647 - MIDLAND, MI 48641-1647 (989) 837-3341

FIRST-CLASS MAIL
U.S. POSTAGE PAID
PERMIT NO. 5
MIDLAND, MI 48640

ACCOUNT NUMBER **20925-002** CYCLE **03** BILL DATE **12/22/2025**

SERVICE ADDRESS
2600 Washington ST Wa 2

SERVICE PERIOD **9/1/2025 - 11/30/2025** # OF DAYS **71**

Cityofmidlandmi.gov/pay

Service **001892341** Curr Read **2,385.0** Read Type **Removal** Usage (TGAL) **23**

Description of Charges	AMOUNT
Sewer Usage	82.11
Sewer Readiness-To-Serve	304.48
Water Usage	63.94
Water Readiness-To-Serve	229.81

TOTAL CURRENT CHARGES	680.34
PREVIOUS BALANCE	0.00
TOTAL DUE	680.34

DUE DATE

Pay **748.38** After **1/22/2026**

Checks Payable to **CITY OF MIDLAND**

P.O. BOX 1647 - MIDLAND, MI 48641-1647 (989) 837-3341

FIRST-CLASS MAIL
U.S. POSTAGE PAID
PERMIT NO. 5
MIDLAND, MI 48640

ACCOUNT NUMBER	CYCLE	BILL DATE
4326-001	03	12/22/2025

SERVICE ADDRESS
1301 Eastlawn DR
SERVICE PERIOD
9/1/2025 - 11/30/2025
OF DAYS
99

Cityofmidlandmi.gov/pay

Service	Curr Read	Read Type	Usage (TGAL)
014251080	626.0	Routine	208

Description of Charges	AMOUNT
Sewer Usage	742.56
Sewer Readiness-To-Serve	685.72
Water Usage	578.24
Water Readiness-To-Serve	517.55

TOTAL CURRENT CHARGES	2,524.07
PREVIOUS BALANCE	0.00
TOTAL DUE	2,524.07
DUE DATE	

Pay 2,776.48 After 1/22/2026

Checks Payable to **CITY OF MIDLAND**

P.O. BOX 1647 - MIDLAND, MI 48641-1647 (989) 837-3341

FIRST-CLASS MAIL
U.S. POSTAGE PAID
PERMIT NO. 5
MIDLAND, MI 48640

ACCOUNT NUMBER 17090-002 **CYCLE** 03 **BILL DATE** 12/22/2025

SERVICE ADDRESS
2620 Washington ST

Service 052684188 **Curr Read** 480.0 **Read Type** Routine **Usage (TGAL)** 6

SERVICE PERIOD 9/1/2025 - 11/30/2025 **# OF DAYS** 99

Description of Charges	AMOUNT
Sewer Usage	21.42
Sewer Readiness-To-Serve	342.54
Water Usage	16.68
Water Readiness-To-Serve	258.54

Cityofmidlandmi.gov/pay

TOTAL CURRENT CHARGES	639.18
PREVIOUS BALANCE	0.00
TOTAL DUE	639.18
DUE DATE	

Pay 703.10 After 1/22/2026

Checks Payable to **CITY OF MIDLAND**

P.O. BOX 1647 - MIDLAND, MI 48641-1647 (989) 837-3341

FIRST-CLASS MAIL
U.S. POSTAGE PAID
PERMIT NO. 5
MIDLAND, MI 48640

ACCOUNT NUMBER 17458-001 **CYCLE** 03 **BILL DATE** 12/22/2025

SERVICE ADDRESS
800 W Chapel LN
SERVICE PERIOD 9/1/2025 - 11/30/2025
OF DAYS 102

Service 090020276 **Curr Read** 3,576.0 **Read Type** Routine **Usage (TGAL)** 292

Cityofmidlandmi.gov/pay

Description of Charges	AMOUNT
Sewer Usage	1,042.44
Sewer Readiness-To-Serve	342.54
Water Usage	811.76
Water Readiness-To-Serve	258.54
FP <= 6"	41.50

TOTAL CURRENT CHARGES

2,496.78

PREVIOUS BALANCE

0.00

TOTAL DUE

2,496.78

DUE DATE

Pay 2,746.46 After 1/22/2026

Checks Payable to **CITY OF MIDLAND**

P.O. BOX 1647 - MIDLAND, MI 48641-1647 (989) 837-3341

FIRST-CLASS MAIL
U.S. POSTAGE PAID
PERMIT NO. 5
MIDLAND, MI 48640

ACCOUNT NUMBER **13163-001** CYCLE **03** BILL DATE **12/22/2025**

SERVICE ADDRESS
1305 E Sugnet RD
SERVICE PERIOD **9/1/2025 - 11/30/2025** # OF DAYS **98**

Cityofmidlandmi.gov/pay

Service	Curr Read	Read Type	Usage (TGAL)
004308110	2,460.0	Routine	0
005475766	3,996.0	Manual Estimate	400
Description of Charges			AMOUNT
Sewer Usage			1,428.0
Sewer Readiness-To-Serve			685.72
Water Usage			1,112.0
Water Readiness-To-Serve			517.55
Irrigation			0.00
Irrigation Readiness-To-Serve			517.55

TOTAL CURRENT CHARGES	4,260.8
PREVIOUS BALANCE	0.00
TOTAL DUE	4,260.8
DUE DATE	

Pay 4,686.90 After 1/22/2026

Checks Payable to **CITY OF MIDLAND**

P.O. BOX 1647 - MIDLAND, MI 48641-1647 (989) 837-3341

FIRST-CLASS MAIL
U.S. POSTAGE PAID
PERMIT NO. 5
MIDLAND, MI 48640

ACCOUNT NUMBER CYCLE BILL DATE
13143-001 **03** **12/22/2025**

SERVICE ADDRESS
1105 E Sugnet RD
SERVICE PERIOD # OF DAYS
9/1/2025 - 11/30/2025 **99**

Service Curr Read Read Type Usage (TGAL)
090020265 **2,120.0** **Routine** **244**

Cityofmidlandmi.gov/pay

Description of Charges	AMOUNT
Sewer Usage	871.08
Sewer Readiness-To-Serve	342.54
Water Usage	678.32
Water Readiness-To-Serve	258.54
FP <= 6"	41.50

TOTAL CURRENT CHARGES	2,191.98
PREVIOUS BALANCE	0.00
TOTAL DUE	2,191.98
DUE DATE	

Pay 2,411.18 After 1/22/2026

Checks Payable to **CITY OF MIDLAND**

P.O. BOX 1647 - MIDLAND, MI 48641-1647 (989) 837-3341

FIRST-CLASS MAIL
U.S. POSTAGE PAID
PERMIT NO. 5
MIDLAND, MI 48640

ACCOUNT NUMBER CYCLE BILL DATE
12262-001 03 12/22/2025

SERVICE ADDRESS
5700 Siebert ST

SERVICE PERIOD # OF DAYS
9/1/2025 - 11/30/2025 102

Cityofmidlandmi.gov/pay

Service Curr Read Read Type Usage (TGAL)
090020277 3,092.0 Routine 260

Description of Charges	AMOUNT
Sewer Usage	928.20
Sewer Readiness-To-Serve	342.54
Water Usage	722.80
Water Readiness-To-Serve	258.54

TOTAL CURRENT CHARGES	2,252.0
PREVIOUS BALANCE	0.00
TOTAL DUE	2,252.0
DUE DATE	

Pay 2,477.28 After 1/22/2026

Checks Payable to **CITY OF MIDLAND**
 P.O. BOX 1647 - MIDLAND, MI 48641-1647 (989) 837-3341

FIRST-CLASS MAIL
 U.S. POSTAGE PAID
 PERMIT NO. 5
 MIDLAND, MI 48640

ACCOUNT NUMBER CYCLE BILL DATE
 2579-001 03 12/22/2025

SERVICE ADDRESS
 600 E Carpenter ST
 SERVICE PERIOD # OF DAYS
 9/1/2025 - 11/30/2025 98

Service	Curr Read	Read Type	Usage (TGAL)
006414253	66.0	Routine	0
090020271	658.0	Routine	26

Cityofmidlandmi.gov/pay

Description of Charges	AMOUNT
Sewer Usage	92.82
Sewer Readiness-To-Serve	342.54
Water Usage	72.28
Water Readiness-To-Serve	258.54
Irrigation	0.00
Irrigation Readiness-To-Serve	161.53

TOTAL CURRENT CHARGES	927.71
PREVIOUS BALANCE	0.00
TOTAL DUE	927.71

DUE DATE

Pay 1,020.49 After 1/22/2026

Checks Payable to **CITY OF MIDLAND**

P.O. BOX 1647 - MIDLAND, MI 48641-1647 (989) 837-3341

FIRST-CLASS MAIL
U.S. POSTAGE PAID
PERMIT NO. 5
MIDLAND, MI 48640

ACCOUNT NUMBER **6622-001** CYCLE **03** BILL DATE **12/22/2025**

SERVICE ADDRESS **406 E Hines ST**
SERVICE PERIOD **9/1/2025 - 11/30/2025** # OF DAYS **97**

Cityofmidlandmi.gov/pay

Service	Curr Read	Read Type	Usage (TGAL)
055310252	2,902.0	Routine	19
Description of Charges			AMOUNT
Sewer Usage			67.83
Sewer Readiness-To-Serve			107.33
Water Usage			52.82
Water Readiness-To-Serve			81.00

TOTAL CURRENT CHARGES	308.98
PREVIOUS BALANCE	0.00
TOTAL DUE	308.98

DUE DATE

Pay 339.88 After 1/22/2026

Checks Payable to **CITY OF MIDLAND**

P.O. BOX 1647 - MIDLAND, MI 48641-1647 (989) 837-3341

FIRST-CLASS MAIL
U.S. POSTAGE PAID
PERMIT NO. 5
MIDLAND, MI 48640

ACCOUNT NUMBER **5198-001** CYCLE **03** BILL DATE **12/22/2025**

SERVICE ADDRESS **805 George ST**
SERVICE PERIOD **9/1/2025 - 11/30/2025** # OF DAYS **97**

Cityofmidlandmi.gov/pay

Service **055274970** Curr Read **953.0** Read Type **Routine** Usage (TGAL) **7**

Description of Charges	AMOUNT
Sewer Usage	24.99
Sewer Readiness-To-Serve	214.01
Water Usage	19.46
Water Readiness-To-Serve	161.53
FP <= 6"	41.50

TOTAL CURRENT CHARGES	461.49
PREVIOUS BALANCE	0.00
TOTAL DUE	461.49
DUE DATE	

Pay 507.64 After 1/22/2026

Checks Payable to **CITY OF MIDLAND**

P.O. BOX 1647 - MIDLAND, MI 48641-1647 (989) 837-3341

FIRST-CLASS MAIL
U.S. POSTAGE PAID
PERMIT NO. 5
MIDLAND, MI 48640

ACCOUNT NUMBER **6560-001** CYCLE **03** BILL DATE **12/22/2025**

SERVICE ADDRESS
411 E Hines ST
SERVICE PERIOD **9/1/2025 - 11/30/2025** # OF DAYS **97**

Service **005133490** Curr Read **1,286.0** Read Type **Routine** Usage (TGAL) **20**

Cityofmidlandmi.gov/pay

Description of Charges	AMOUNT
Sewer Usage	71.40
Sewer Readiness-To-Serve	107.33
Water Usage	55.60
Water Readiness-To-Serve	81.00

TOTAL CURRENT CHARGES	315.33
PREVIOUS BALANCE	0.00
TOTAL DUE	315.33

DUE DATE

Pay 346.86 After 1/22/2026

Checks Payable to **CITY OF MIDLAND**

P.O. BOX 1647 - MIDLAND, MI 48641-1647 (989) 837-3341

FIRST-CLASS MAIL
U.S. POSTAGE PAID
PERMIT NO. 5
MIDLAND, MI 48640

ACCOUNT NUMBER CYCLE BILL DATE
4215-001 **03** **12/22/2025**

SERVICE ADDRESS
5500 Drake ST

SERVICE PERIOD # OF DAYS
9/1/2025 - 11/30/2025 **97**

Service Curr Read Read Type Usage (TGAL)
090020274 **2,231.0** **Routine** **188**

Cityofmidlandmi.gov/pay

Description of Charges	AMOUNT
Sewer Usage	671.16
Sewer Readiness-To-Serve	342.54
Water Usage	522.64
Water Readiness-To-Serve	258.54

TOTAL CURRENT CHARGES	1,794.88
PREVIOUS BALANCE	0.00
TOTAL DUE	1,794.88
DUE DATE	

Pay 1,974.37 After 1/22/2026

**Midland Public Schools
Financial Dashboard
07/01/25-02/28/2026**

	2025-26	2024-2025
February total cash receipts	\$ 10,475,547	\$ 10,768,245
February total expenses	\$ 9,354,396	\$ 7,988,236
YTD athletic revenue	\$ 401,867	\$ 322,537
YTD athletic expenses	\$ 1,127,522	\$ 1,173,642
Bond Issue 2015 Debt Retirement	\$ 230,145	\$ 1,925,852
Bond Issue 2019 Debt Retirement	\$ 1,358,359	\$ 1,274,125
Energy Conservation Debt Retirement	\$ 279,970	\$ 247,810
2021 Refunding Bond Debt Retirement	\$ 2,963,121	\$ 1,231,348
Bond Issue 2023 Debt Retirement	\$ 782,877	\$ 1,128,331
Capital Projects fund available cash	\$ 1,954,769	\$ 2,340,529
Bond Issue 2019 Cash and Investments	\$ -	\$ 12,837
2021 Energy Conservation Bond	\$ 1,642	\$ 79,011
Bond Issue 2023 Cash and Investments	\$ 4,643,950	\$ 6,015,385
General Fund interest earned year to date	\$ 622,842	\$ 827,278
Payrolls paid to date	17	17

General Fund Revenue by Source

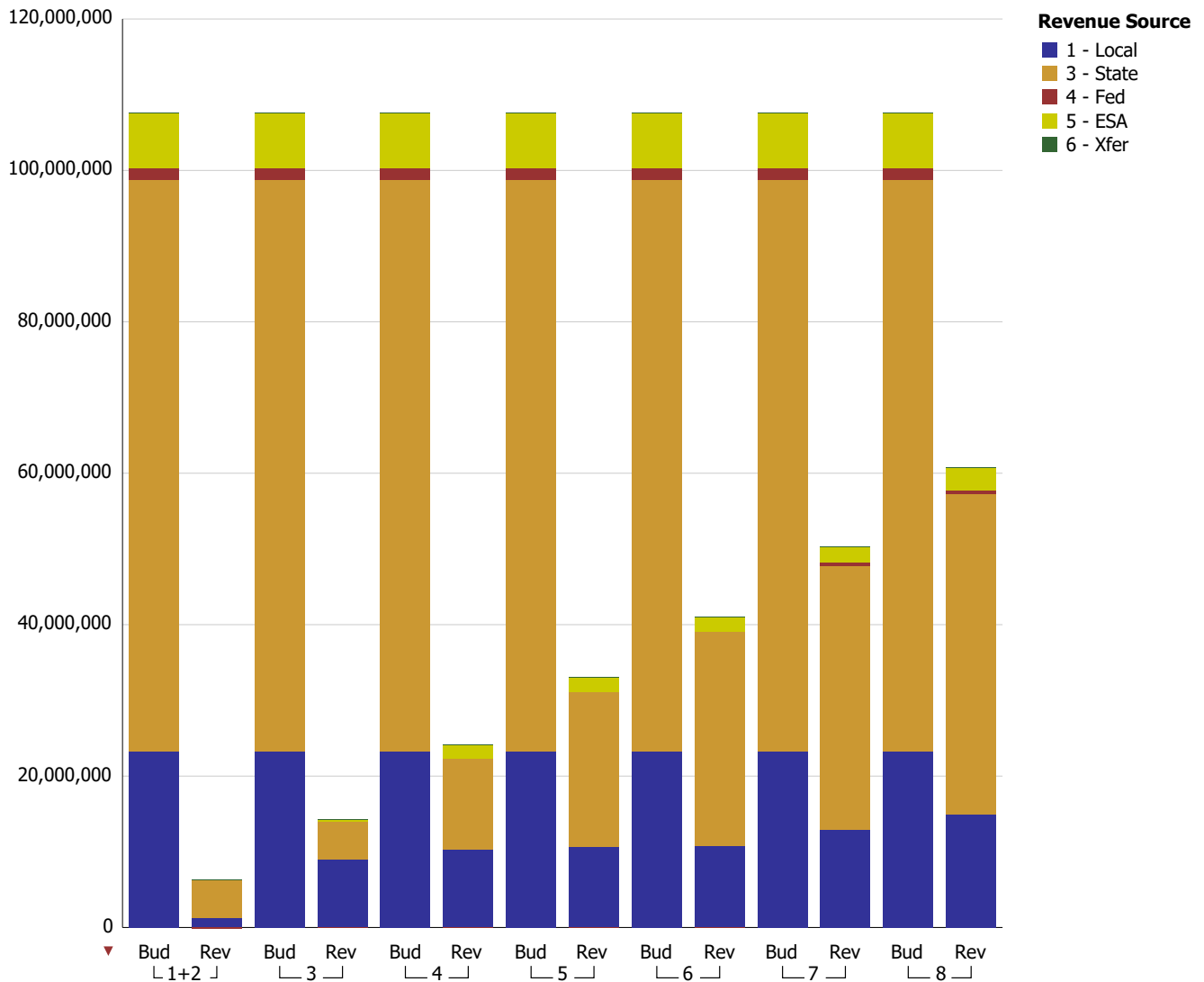

Period					
Period	Revenue Source	YTD Budget	Period Receipts	YTD Revenue	YTD Remaining
8	1 - Local	\$23,257,428.00	\$2,017,635.81	\$14,950,301.09	\$8,307,126.91
8	3 - State	\$75,501,638.00	\$7,462,166.63	\$42,355,612.09	\$33,146,025.91
8	4 - Fed	\$1,552,145.00	\$21,206.00	\$408,351.41	\$1,143,793.59
8	5 - ESA	\$7,312,294.00	\$974,538.45	\$3,090,499.69	\$4,221,794.31
8	6 - Xfer	\$8,000.00	\$0.00	\$0.00	\$8,000.00
Summary		\$107,631,505.00	\$10,475,546.89	\$60,804,764.28	\$46,826,740.72

General Fund Expenses by Object

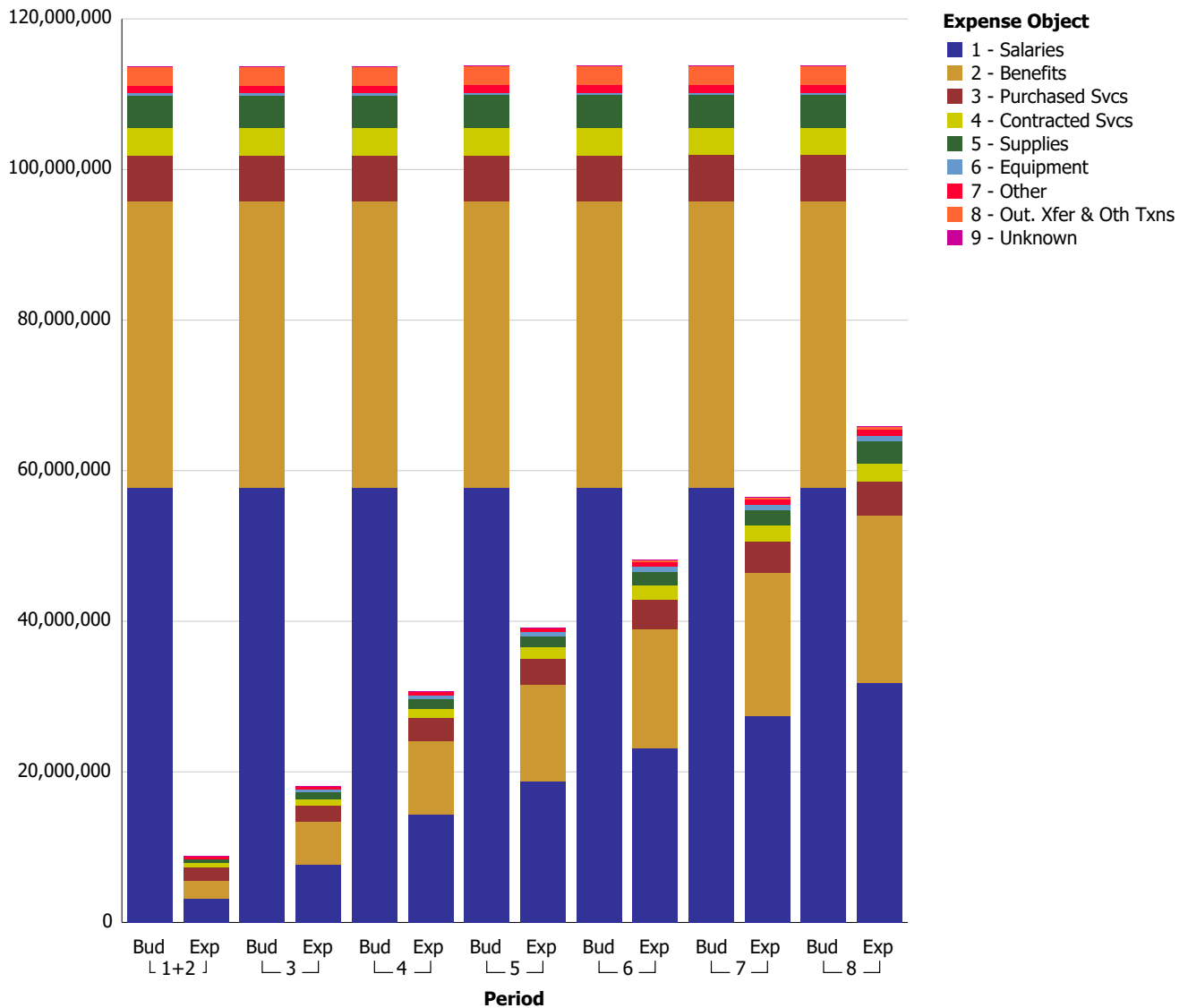

Period	Expense Object	YTD Budget	Period Expenditures	Encumbrances Outstanding	YTD Expenditures	Available Balance
8	1 - Salaries	\$57,787,794.00	\$4,401,052.85	\$0.00	\$31,753,030.17	\$26,034,763.83
8	2 - Benefits	\$38,004,842.00	\$3,194,012.26	\$0.00	\$22,322,684.61	\$15,682,157.39
8	3 - Purchased Svcs	\$6,097,801.00	\$440,291.16	\$631,559.64	\$4,522,540.30	\$943,701.06
8	4 - Contracted Svcs	\$3,673,468.00	\$274,856.00	\$1,064,468.70	\$2,398,367.63	\$210,631.67
8	5 - Supplies	\$4,372,365.00	\$792,983.79	\$834,001.72	\$2,912,887.60	\$625,475.68
8	6 - Equipment	\$253,400.00	\$98,224.42	\$100,305.00	\$766,612.08	(\$613,517.08)
8	7 - Other	\$1,052,296.00	\$152,459.13	\$46,449.50	\$831,156.09	\$174,690.41
8	8 - Out. Xfer & Oth Txns	\$2,541,207.00	\$516.80	\$3,668.97	\$295,776.95	\$2,241,761.08
8	9 - Unknown	\$0.00	\$0.00	\$0.00	\$0.00	\$0.00
Summary		\$113,783,173.00	\$9,354,396.41	\$2,680,453.53	\$65,803,055.43	\$45,299,664.04

General Fund Expenses by Function

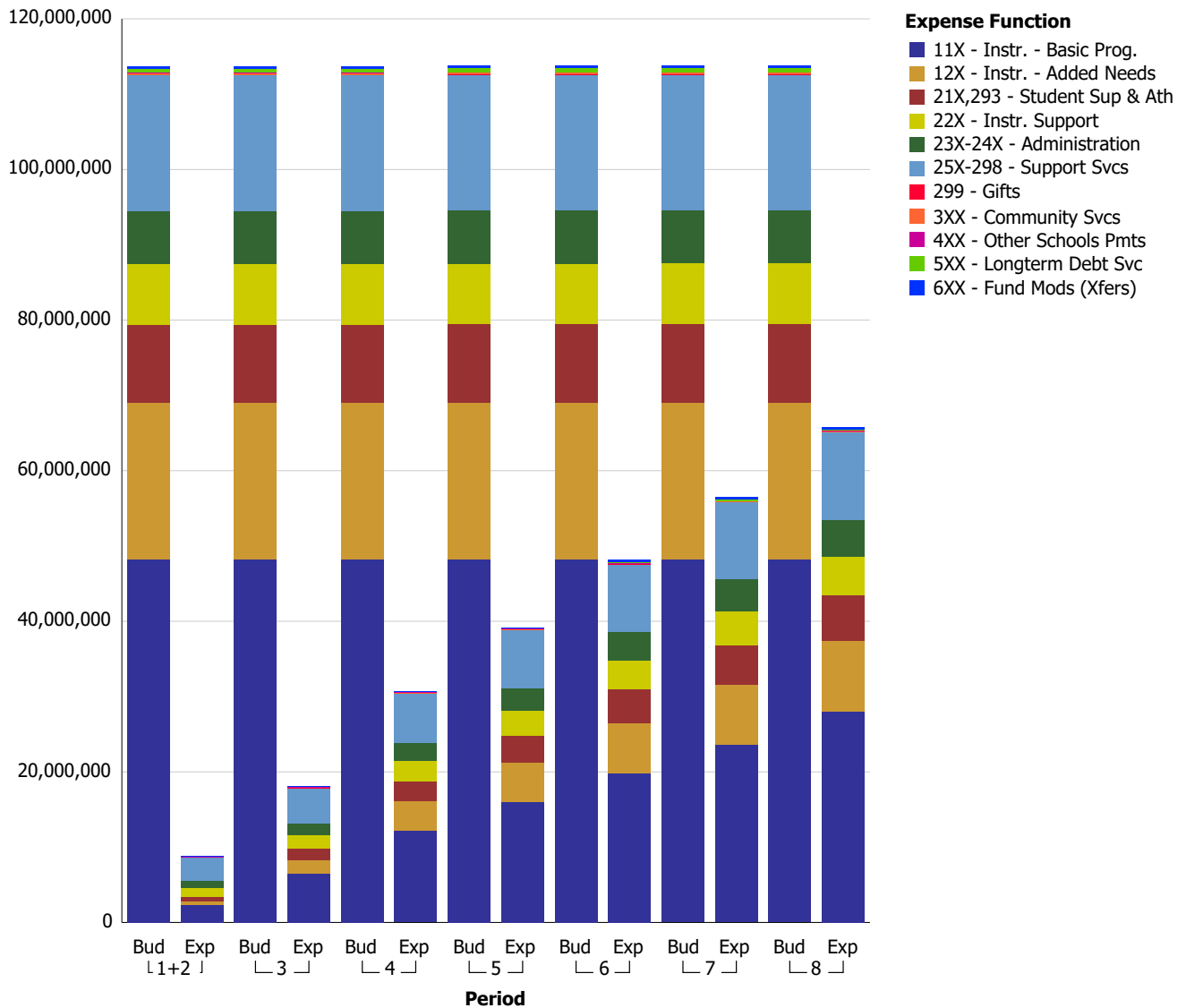

Period	Expense Function	YTD Budget	Period Expenditures	Encumbrances Outstanding	YTD Expenditures	Available Balance
8	11X - Instr. - Basic Prog.	\$48,257,597.00	\$4,366,843.90	\$209,327.68	\$28,022,869.29	\$20,025,400.03
8	12X - Instr. - Added Needs	\$20,786,246.00	\$1,407,635.81	\$34,412.38	\$9,341,226.62	\$11,410,607.00
8	21X,293 - Student Sup & Ath	\$10,417,656.00	\$857,554.41	\$184,252.98	\$6,152,202.36	\$4,081,200.66
8	22X - Instr. Support	\$8,047,958.00	\$584,482.95	\$130,083.09	\$5,027,774.39	\$2,890,100.52
8	23X-24X - Administration	\$7,123,001.00	\$637,752.03	\$100,886.01	\$4,972,273.39	\$2,049,841.60
8	25X-298 - Support Svcs	\$17,994,742.00	\$1,453,517.79	\$1,980,846.89	\$11,597,305.52	\$4,416,589.59
8	299 - Gifts	\$25,000.00	\$3,521.60	\$0.00	\$24,543.89	\$456.11
8	3XX - Community Svcs	\$292,051.00	\$22,765.67	\$0.00	\$123,131.97	\$168,919.03
8	4XX - Other Schools Pmts	\$0.00	\$0.00	\$0.00	\$98,450.00	(\$98,450.00)
8	5XX - Longterm Debt Svc	\$553,222.00	\$20,322.25	\$40,644.50	\$162,578.00	\$349,999.50
8	6XX - Fund Mods (Xfers)	\$285,700.00	\$0.00	\$0.00	\$280,700.00	\$5,000.00
Summary		\$113,783,173.00	\$9,354,396.41	\$2,680,453.53	\$65,803,055.43	\$45,299,664.04

**Midland Public Schools
Financial Dashboard
07/01/25-02/28/2026**

	2025-26	2024-2025
February total cash receipts	\$ 10,475,547	\$ 10,768,245
February total expenses	\$ 9,354,396	\$ 7,988,236
YTD athletic revenue	\$ 401,867	\$ 322,537
YTD athletic expenses	\$ 1,127,522	\$ 1,173,642
Bond Issue 2015 Debt Retirement	\$ 230,145	\$ 1,925,852
Bond Issue 2019 Debt Retirement	\$ 1,358,359	\$ 1,274,125
Energy Conservation Debt Retirement	\$ 279,970	\$ 247,810
2021 Refunding Bond Debt Retirement	\$ 2,963,121	\$ 1,231,348
Bond Issue 2023 Debt Retirement	\$ 782,877	\$ 1,128,331
Capital Projects fund available cash	\$ 1,954,769	\$ 2,340,529
Bond Issue 2019 Cash and Investments	\$ -	\$ 12,837
2021 Energy Conservation Bond	\$ 1,642	\$ 79,011
Bond Issue 2023 Cash and Investments	\$ 4,643,950	\$ 6,015,385
General Fund interest earned year to date	\$ 622,842	\$ 827,278
Payrolls paid to date	17	17

Midland Public Schools
Board Agenda Obligation Distribution
For the months of February 2026

	<u>Through</u> <u>2/15/2026</u>	<u>Through</u> <u>2/28/2026</u>	<u>Totals</u>
General Fund / Athletics	\$ 2,699,004	\$ 1,229,037	\$ 3,928,041
Capital Projects	5,344	87,599	92,942
2015 Debt Retirement	-	-	-
2019 Debt Retirement	388	1,153	1,541
2021 Energy Conservation Debt Ret.	-	-	-
2021 Refunding Debt Retirement	717	2,127	2,843
2023 Debt Retirement	259	768	1,027
Bond 2019 Capital Projects	-	-	-
Bond 2023 Capital Projects	11,686	-	11,686
2021 Energy Conservation Bond	-	-	-
School Services:			
School Stores	1,104	-	1,104
Food Service	-	743,056	743,056
Student Activities	<u>10,387</u>	<u>29,656</u>	<u>40,043</u>
Sub-totals	2,728,889	2,093,395	4,822,284
Federal Withholding			298,676
State Withholding/Sales Tax			148,552
Social Security/Medicare			638,835
Payroll Transfers			7,315
ACH Transfers			2,908,800
Consumers payments paid electronically			136,423
Health Savings Accounts			116,728
Edustaff payroll (contracted substitutes)			152,939
Purchase Card Transactions January			360,022
February Distributions			<u><u>\$9,590,572</u></u>

2025-2026 Expenses

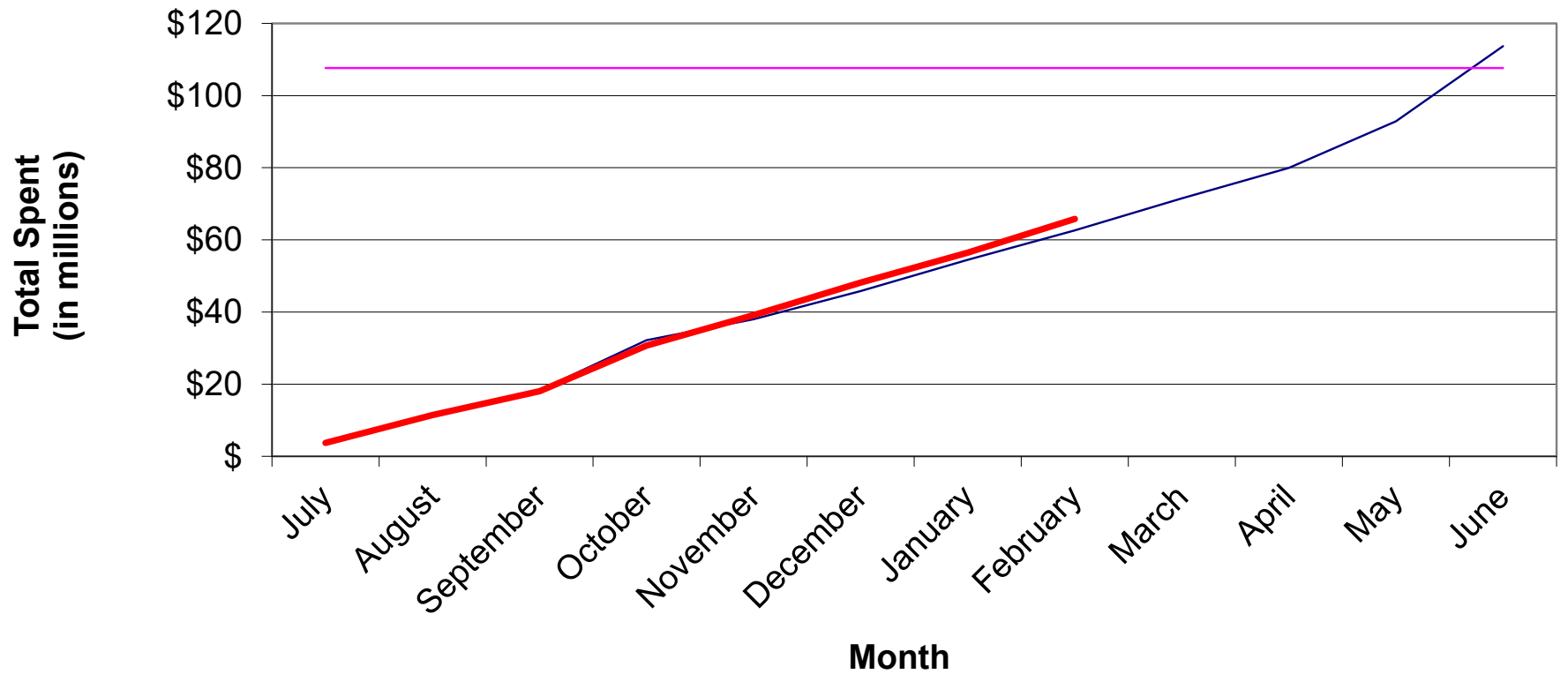

4. 6. Legal Payments

Recommendation

Approval is requested to authorize legal payments to the below list for professional legal fees:

- Thrun Law Firm, P.C., for \$1,540.00, invoice number 312086, dated March 26, 2026
- Thrun Law Firm, P.C., for \$3,430.00, invoice number 312087, dated March 26, 2026
- Thrun Law Firm, P.C., for \$3,815.00, invoice number 312088, dated March 26, 2026
- Thrun Law Firm, P.C., for \$3,820.00, invoice number 312089, dated March 26, 2026

Supporting Documents



[Thrun Invoice 312089](#)



[Thrun Invoice 312088](#)



[Thrun Invoice 312086](#)



[Thrun Invoice 310287](#)

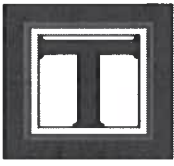

THRUN

LAW FIRM, P.C.

2900 WEST ROAD, SUITE 400
 EAST LANSING, MI 48823-1391
 MAILING ADDRESS: P.O. BOX 2575
 EAST LANSING, MI 48826-2575
 TAX ID#: 38-2201807

March 26, 2026

Board of Education
 Midland Public Schools
 600 East Carpenter Street
 Midland, MI 48640-5417

Invoice# 312089

Our file# 0419 - 00083

Billing through 03/19/2026

Due Process Complaint #(G.P.)

PROFESSIONAL SERVICES

03/02/26	KSB - Attend prehearing conference re: due process complaint	0.20 hrs.	\$60.00
03/02/26	RAD - Confer with attorney re: due process complaints	0.20 hrs.	\$70.00
03/04/26	KSB - Attend prehearing conference	0.20 hrs.	\$60.00
03/05/26	KSB - Review documentation re: due process complaint; prepare exhibit and witness list (3); email exchange with special education director re: exhibits	1.20 hrs.	\$360.00
03/06/26	KSB - Continue preparing exhibit and witness list (3)	0.20 hrs.	\$60.00
03/09/26	RAD - Correspondence to MOAHR re: subpoena	0.20 hrs.	\$70.00
03/10/26	RAD - Correspondence with MOAHR re: oral argument; correspondence with A. Gates; prepare exhibits	0.80 hrs.	\$280.00
03/12/26	RAD - Finalize exhibit and witness list	2.00 hrs.	\$700.00
03/16/26	KSB - Prepare petitioner's response to respondent's requests; research re: same; prepare appearance	1.30 hrs.	\$390.00
03/17/26	KSB - Prepare for due process hearing; research re: same; meet with witnesses re: same	0.90 hrs.	\$270.00
03/18/26	KSB - Review exhibits; prepare for due process hearing; email exchange with special education director re: same	2.00 hrs.	\$600.00
03/19/26	KSB - Review exhibits; prepare for due process hearing; phone conversation with special education director re: same	3.00 hrs.	\$900.00

Total Fees \$3,820.00

BILLING SUMMARY

Total professional services \$3,820.00

Total charges for this invoice \$3,820.00

Total balance now due \$3,820.00

Statement due upon receipt. Please make checks payable and remit to Thrun Law Firm, P.C., P.O. Box 2575, East Lansing MI 48826-2575. If you have questions, please contact Alex Rozell by phone 517-374-4530, fax 517-484-0041, or email arozell@thrunlaw.com

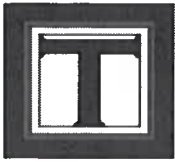

THRUN
LAW FIRM, P.C.

2900 WEST ROAD, SUITE 400
EAST LANSING, MI 48823-1391
MAILING ADDRESS: P.O. BOX 2575
EAST LANSING, MI 48826-2575
TAX ID#: 38-2201807

March 26, 2026

Board of Education
Midland Public Schools
600 East Carpenter Street
Midland, MI 48640-5417

Invoice# 312088
Our file# 0419 - 00082
Billing through 03/19/2026

Due Process Complaint # (A.P.)

PROFESSIONAL SERVICES

03/02/26	KSB - Attend prehearing conference re: due process complaint	0.10 hrs.	\$30.00
03/04/26	KSB - Attend prehearing conference	0.30 hrs.	\$90.00
03/04/26	RAD - Attend prehearing conference call; correspondence to administrative team re: same	0.80 hrs.	\$280.00
03/05/26	KSB - Review documentation re: due process complaint; prepare exhibit and witness list (3); email exchange with special education director re: exhibits	1.10 hrs.	\$330.00
03/06/26	KSB - Continue preparing exhibit and witness list (3)	0.20 hrs.	\$60.00
03/09/26	RAD - Correspondence to MOAHR re: subpoena	0.20 hrs.	\$70.00
03/10/26	RAD - Correspondence with MOAHR re: oral argument; prepare exhibits; correspondence with A. Gates re: hearing	0.60 hrs.	\$210.00
03/12/26	RAD - Finalize exhibit and witness list	1.50 hrs.	\$525.00
03/16/26	KSB - Prepare petitioner's response to respondent's requests; research re: same; prepare appearance	1.30 hrs.	\$390.00
03/17/26	KSB - Prepare for due process hearing; research re: same; meet with witnesses re: same	0.90 hrs.	\$270.00
03/18/26	KSB - Review exhibits; prepare for due process hearing; email exchange with special education director re: same	2.10 hrs.	\$630.00
03/19/26	KSB - Review exhibits; prepare for due process hearing; phone conversation with special education director re: same	3.10 hrs.	\$930.00

Total Fees ~~\$3,815.00~~

BILLING SUMMARY

Total professional services \$3,815.00
Total charges for this invoice \$3,815.00
Total balance now due \$3,815.00

Statement due upon receipt. Please make checks payable and remit to Thrun Law Firm, P.C., P.O. Box 2575, East Lansing MI 48826-2575. If you have questions, please contact Alex Rozell by phone 517-374-4530, fax 517-484-0041, or email arozell@thrunlaw.com

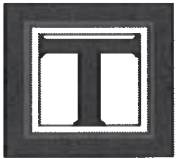

THRUN
LAW FIRM, P.C.

2900 WEST ROAD, SUITE 400
EAST LANSING, MI 48823-1391
MAILING ADDRESS: P.O. BOX 2575
EAST LANSING, MI 48826-2575
TAX ID#: 38-2201807

March 26, 2026

Board of Education
Midland Public Schools
600 East Carpenter Street
Midland, MI 48640-5417

Invoice# 312086
Our file# 0419 - 00001
Billing through 03/19/2026

General

Balance from statement dated	February 26, 2026	\$2,730.00
Payments received since last invoice		\$2,730.00
Accounts receivable balance carried forward		\$0.00

PROFESSIONAL SERVICES

02/23/26	RAD - Draft, revise, file due process complaints (3)	3.60 hrs.	\$1,260.00
03/02/26	RAD - Correspondence to K. Stark re: FOIA response	0.40 hrs.	\$140.00
03/19/26	RMD - Phone conversation with superintendent re: personnel matters	0.40 hrs.	\$140.00
Total Fees			\$1,540.00

BILLING SUMMARY

Total professional services \$1,540.00

Total charges for this invoice \$1,540.00

Total balance now due \$1,540.00

Statement due upon receipt. Please make checks payable and remit to Thrun Law Firm, P.C., P.O. Box 2575, East Lansing MI 48826-2575. If you have questions, please contact Alex Rozell by phone 517-374-4530, fax 517-484-0041, or email arozell@thrunlaw.com

4/8/2026
[Signature]

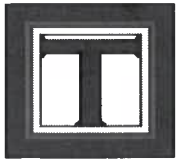

THRUN

LAW FIRM, P.C.

2900 WEST ROAD, SUITE 400
 EAST LANSING, MI 48823-1391
 MAILING ADDRESS: P.O. BOX 2575
 EAST LANSING, MI 48826-2575
 TAX ID#: 38-2201807

March 26, 2026

Board of Education
 Midland Public Schools
 600 East Carpenter Street
 Midland, MI 48640-5417

Invoice# 312087
 Our file# 0419-00081
 Billing through 03/19/2026

Due Process Complaint # (A.Y.)

PROFESSIONAL SERVICES

03/02/26	KSB - Attend prehearing conference re: due process complaint	0.10 hrs.	\$30.00
03/04/26	KSB - Attend prehearing conference	0.30 hrs.	\$90.00
03/05/26	KSB - Review documentation re: due process complaint; prepare exhibit and witness list (3); email exchange with special education director re: exhibits	1.10 hrs.	\$330.00
03/05/26	RAD - Confer with attorney re: due process complaint	0.20 hrs.	\$70.00
03/06/26	KSB - Continue preparing exhibit and witness list (3)	0.20 hrs.	\$60.00
03/09/26	RAD - Correspondence to MOAHR re: subpoena	0.20 hrs.	\$70.00
03/10/26	RAD - Correspondence with MOAHR re: oral argument; prepare exhibits	0.50 hrs.	\$175.00
03/11/26	RAD - Correspondence to A. Gates re: subpoena; review order re: same	0.30 hrs.	\$105.00
03/12/26	RAD - Finalize exhibit and witness list	0.80 hrs.	\$280.00
03/16/26	KSB - Prepare petitioner's response to respondent's requests; research re: same; prepare appearance	1.30 hrs.	\$390.00
03/17/26	KSB - Prepare for due process hearing; research re: same; meet with witnesses re: same	0.90 hrs.	\$270.00
03/18/26	KSB - Review exhibits; prepare for due process hearing; email exchange with special education director re: same	2.10 hrs.	\$630.00
03/19/26	KSB - Review exhibits; prepare for due process hearing; phone conversation with special education director re: same	3.10 hrs.	\$930.00

Total Fees \$3,430.00

BILLING SUMMARY

Total professional services \$3,430.00

Total charges for this invoice \$3,430.00

Total balance now due \$3,430.00

Statement due upon receipt. Please make checks payable and remit to Thrun Law Firm, P.C., P.O. Box 2575, East Lansing MI 48826-2575. If you have questions, please contact Alex Rozell by phone 517-374-4530, fax 517-484-0041, or email arozell@thrunlaw.com

5. Board of Education Matters: Presentations to the Board

5. 1. Shining Stars

Recommendation

Presenter: Superintendent Miller-Nelson

5. 2. Spotlight on Excellence - Central Park Elementary

Recommendation

Presenter: Chelsea Sauve

5. 3. Facility Planning Update (President Rausch)

5. 4. Facility Planning Workshop

6. Requests to Address the Board

Summary

Citizens are required to limit public comment to three minutes, except when this requirement is waived by the board president during the meeting. A designated timekeeper will communicate to the individual who is addressing the board at three minutes. The Board of Education highly values public comment and input; however, the board meeting format is designed to facilitate the evening's agenda and, therefore, restricts board members from engaging in conversation with speakers or immediately responding to questions. Questions and concerns may be addressed by the board later in the agenda and may be assigned for follow-up by the board or superintendent at a later date.

To ensure due process and respect of individual rights, the District maintains a formal process for handling complaints against individuals. A problem involving an individual or specific incident is best handled through administrative channels. For assistance, please contact the superintendent's office.

Speakers are asked to express themselves in a civil manner, with due respect for the dignity and privacy of others who may be affected by the comments. While it is not the District's intent to stifle public comment, speakers should be aware that if statements violate the rights of others under the law of defamation or invasion of privacy, the speaker may be held legally responsible. If the speaker is unsure of the legal ramifications of what they are about to say, the District urges them to consult first with a legal advisor.

7. Curriculum, Instruction, and Assessment

Recommendation

Study Committee Chair: Secretary Ringgold; Staff Resource Person: Associate Superintendent Weaver

7. 1. Curriculum, Instruction, and Assessment Study Committee Meeting Notes from March 16, 2026 and April 8, 2026

Supporting Documents



[3-16-26 CIA Meeting Notes](#)



[4-8-2026 CIA Meeting Notes \(1\)](#)

Curriculum, Instruction, Assessment (CIA) Study Committee Meeting Notes

Meeting Date: March 16, 2026

Members Present: Jennifer Ringgold, Chair; Ann Horowitz; Meki Craig; Ken Weaver; Penny Miller-Nelson

Guests Present: Jennifer Servoss, Troy Lynch, Andrea Jozwiak, Viloshinee Murugan, and Lucas Peless

Meeting Location: Admin Building

The meeting started at 1:30 pm.

1. Ken Weaver, Jennifer Servoss, Troy Lynch, Andrea Jozwiak, Viloshinee Murugan, and Lucas Peless presented Staff Development Proposals for the 2026-27 school year.
2. Troy Lynch presented on the Artificial Intelligence software pilot that is being conducted in April and May by classroom teachers.
3. Andrea Jozwiak presented the updated sex education video resource for use in 5th-grade maturation units.

The meeting adjourned at 2:45 pm.

CIA Meetings are scheduled for the third Monday (Board Meeting Monday), 1:30-2:45.

Remaining CIA Meeting Dates 2025-26: April 20 and May 18

Curriculum, Instruction, Assessment (CIA) Study Committee Meeting Notes

Meeting Date: April 8, 2026

Members Present: Jennifer Ringgold, Chair; Ann Horowitz; Meki Craig; Ken Weaver; Penny Miller-Nelson; Anna Wamack; Brian Brutyn

Guests Present: Steven Gunther, GMB; Kenny Babinski and Kevin Bouchey from Clark Construction

Meeting Location: MPS Administration Building, Conference Rooms C&D

The meeting started at 8:00 am.

Strategic Planning - The administration team is developing the full strategic plan, and components will be shared with the Board once complete.

Facilities Assessment - The committee discussed the facility assessment, the work of the facility steering team, and information gathered at the community engagement sessions.

The meeting adjourned at 9:30 am.

CIA Meetings are scheduled for the third Monday (Board Meeting Monday), 1:30-2:45.
Remaining CIA Meeting Dates 2025-26: April 20, and May 18

7. 2. For Action: New School Program

7. 3. For Information: Staff and Curriculum Development Proposals - Summary Proposals for Implementation in 2026-2027 School Year (Weaver)

Recommendation

The district recommends 18 Staff & Curriculum Development Proposals for consideration. Following the 28-day period of public input, they will be presented for action at the May 18, 2026 Board of Education meeting. These proposals reflect the identified needs for curriculum and staff development and align with the continuous improvement process.

The proposals include:

1. MPS Resiliency \$210,106
2. Multi-Tiered System of Supports (MTSS) \$46,070
3. Engineering (CTE) \$296
4. Instructional Design (CTE) \$5,678
5. Development of Xello Assignments and Activities \$9,464
6. Elementary Professional Development \$21,904
7. Sheltered Instruction Observation Protocol (SIOP) \$36,181
8. Online Curriculum & Online Vendor Review Process \$9,925
9. Online Honors Curriculum Review \$1,893
10. NMS MICIP \$17,745
11. Secondary ELA \$12,954
12. Secondary Math \$13,309
13. Secondary Science \$15,067
14. Secondary Social Studies \$31,129
15. Disciplinary Literacy \$52,852
16. Artificial Intelligence (AI) \$11,830
17. Blended Learning \$3,549
18. Instructional Technology \$21,294

Staff Development Proposals grand total \$521,246

Anticipated amount from General Fund \$105,867 with remaining potentially from related grants.

Upon approval of these projects and subsequent approval of funding through the budget process, the district team will consult with those leading each project to make decisions about implementation.

Supporting Documents



[4-20-26 Agenda for Curr Office](#)

Staff Development Proposals for Information (Weaver)

Staff and Curriculum Development Proposals - Summary Proposals for Implementation in 2026-2027 School Year

The district recommends 18 Staff & Curriculum Development Proposals for consideration. Following the 28-day period of public input, they will be presented for action at the May 18, 2026 Board of Education meeting. These proposals reflect the identified needs for curriculum and staff development and align with the continuous improvement process.

The proposals include:

1. MPS Resiliency \$210,106
2. Multi-Tiered System of Supports (MTSS) \$46,070
3. Engineering (CTE) \$296
4. Instructional Design (CTE) \$5,678
5. Development of Xello Assignments and Activities \$9,464
6. Elementary Professional Development \$21,904
7. Sheltered Instruction Observation Protocol (SIOP) \$36,181
8. Online Curriculum & Online Vendor Review Process \$9,925
9. Online Honors Curriculum Review \$1,893
10. NMS MICIP \$17,745
11. Secondary ELA \$12,954
12. Secondary Math \$13,309
13. Secondary Science \$15,067
14. Secondary Social Studies \$31,129
15. Disciplinary Literacy \$52,852
16. Artificial Intelligence (AI) \$11,830
17. Blended Learning \$3,549
18. Instructional Technology \$21,294

Staff Development Proposals grand total \$521,246

Anticipated amount from General Fund \$105,867 with remaining potentially from related grants.

Upon approval of these projects, and then subsequent approval of funding through the budget process, the district team will consult with those leading each project to make decisions about implementation.

CIA Study Committee Meeting Notes from March 16, 2026

7. 4. For Information: Sex Education Curriculum Resource Adoption

8. Requests to Address the Board Regarding Public Hearing on Proposed Revisions to Instruction in Sex Education

9. Finance, Facilities and Operations

Recommendation

Study Committee Chair: Member Blasy; Staff Resource Person: Associate Superintendent Wamack

Supporting Documents



[April FFO Study Committee Meeting Notes \(1\)](#)

Finance, Facilities, & Operations Study Committee Meeting Notes

Meeting Date: April 7, 2026, 1:00 pm

Members Present: Brad Blasy, Chair; Scott McFarland, Jon Lauderbach, Penny Miller-Nelson, Brian Brutyn, Anna Wamack

Guests Present: Steven Gunther, GMB
Kevin Bouchey, Clark Construction
Mike Moeggenberg, Midland Public Schools

Meeting Location: MPS Administration Center, Rooms C & D

The meeting started at 1:00 pm

February Financials - February financials were reviewed.

Trailer Mounted Cooler Bid - Administration will propose awarding a bid for a trailer mounted cooler.

Dow High Walk-In Cooler Bid - Administration will propose awarding a bid for a walk-in cooler at Dow High.

Concrete Bid - Administration will propose awarding a bid for concrete work throughout the District.

Food Service Renewal Contract - The committee discussed the State approval of the food service management contract.

Fast Ice Update - The committee discussed the status of Fast Ice building renovations. Administration will propose awarding a bid for camera equipment for Fast Ice.

Strategic Planning - The administration team is developing the full strategic plan, and components will be shared with the Board once complete.

Facilities Assessment - The committee discussed the facilities assessment, the work of the facility steering team, and information gathered at the community engagement sessions.

The meeting adjourned at 2:40 pm

9. 2. For Action: Dow High Walk-In Cooler (Wamack)

Recommendation

Bids were solicited and a tabulation is provided for a walk-in cooler at Dow High. Administration recommends issuing a purchase order to Refrigeration and Mechanical Services of Greenville, MO for \$75,715. Food Service funds will be utilized for this purchase.

Supporting Documents



[_William E. Walters RFP](#)



[_Rolls Mechanical RFP](#)



[_Refrigeration and Mechanical Services](#)



[_Johnson and Wood RFP](#)



[_Dow High Walk In Freezer RFP](#)



[_Dow High Cooler Drawings](#)



[_DHS Walk In Cooler Tally](#)

Bid Form

Total Pricing to Include Engineering, Labor and Materials \$175,000.00

Please Describe Scope of Work to Include Time Frame of Work
Removal of old Freezer/Cooler and all associated piping. Install
Install new Freezer/Cooler and all associated piping. Connect
electrical, install dunnage and rack supplies, check test and
start up of new equipment.
Work duration 6/4/-8/30 2026

Company William E. Walter, Inc.

Title President

Email Address bwenzlick@williamewalter.com

Phone 810.232.7459

My signature certifies that the proposal as submitted complies with all Terms and Conditions as set forth in this RFP.
Signature 

Iran Economic Sanctions Act Certification

I am the President _____ (insert title) of William E. Walter, Inc _____ (insert bidder company name), or I am bidding in my individual capacity ("Bidder"), with authority to submit a binding bid for construction work at Midland Public Schools. I have personal knowledge of the matters described in this Certification, and I am familiar with the Iran Economic Sanctions Act, MCL 129.311, et seq. ("Act"). I am fully aware that the school district will rely on my representations in evaluating bids.

I certify that Bidder is not an Iran-linked business, as that term is defined in the Act. I understand that submission of a false certification may result in contract termination, ineligibility to bid for three (3) years, and a civil penalty of \$250,000 or twice the bid amount, whichever is greater, plus related investigation and legal costs.

Signature

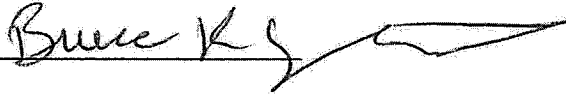

Affidavit of Bidder-Compliance with School Safety Initiative Legislation

The undersigned, the owner or authorized officer of William E. Walter, Inc (the "Bidder"), certifies to Midland Public Schools (the "School District"), that any and all persons who will work directly or indirectly for the Bidder, including, but not limited to, Bidder's employees, agents, vendors, subcontractors or consultants, and who will work at or on any School District property, shall at all times be in compliance with MCL 380.1230, 380.1230a, 380.1230c, 380.1230d, and 380.1230g and have not been convicted of any "listed offenses".¹ The Bidder further warrants and represents that all persons who will work directly or indirectly for the Bidder, including, but not limited to, Bidder's employees, agents, vendors, subcontractors or consultants, and who will work at or on any School District property, shall at all times be in compliance with MCL 380.1230, 380.1230a, 380.1230c, 380.1230d, and 380.1230g. In this regard, Bidder agrees, without limitation, to report within 3 business days to the School District when any such person is charged with a crime listed in Section 1535a(1) of the Revised School Code² or a substantially similar law, and to immediately report to the School District if that person is subsequently convicted, plead guilty or plead no contest to that crime.

BIDDER: William E. Walter, Inc

By: Bruce K. Wenzlick Bruce Wenzlick

Its: President

Bid Form

Total Pricing to Include Labor and Materials \$98,125.00

Please Describe Scope of Work to Include Time Frame of Work

Provide demo of the existing freezer/cooler, including refrigeration equipment

Furnish and install (1) CrownTonk freezer/cooler refrigeration box per bid documents

Furnish and install Heatcraft/Bohn refrigeration equipment for

Furnish and install Cambro shelving/dunnage units per bid document specifications

Furnish and install ACR refrigeration piping w/ armafex insulation on all suction line piping

Refrigeration piping will be leak tested @ 400 psi with nitrogen gas

Refrigeration system will be evacuated down to a minimum of 500 microns and charged with R448

Provide all line voltage and control voltage wiring

Provide 1 yr labor warranty and 4 yr extended compressor warranty (2nd-5th year)

Provide system test, check, and startup

Provide permits, inspections, and plan review

Company Rolls Mechanical

Title Est./Proj. Manager

Email Address phild@jrrolls.com

Phone 810-588-9780

My signature certifies that the proposal as submitted complies with all Terms and Conditions as set forth in this RFP.

Signature 

Any changes required from plan review will be addressed through a change order to the project.

CrownTonka and Heatcraft/Bohn submittals available upon bid award

Iran Economic Sanctions Act Certification

I am the Est./Proj. Manager (insert title) of Rolls Mechanical (insert bidder company name), or I am bidding in my individual capacity ("Bidder"), with authority to submit a binding bid for the demo, purchase and installation of a walk in freezer/cooler to Midland Public Schools. I have personal knowledge of the matters described in this Certification, and I am familiar with the Iran Economic Sanctions Act, MCL 129.311, et seq. ("Act"). I am fully aware that the school district will rely on my representations in evaluating bids.

I certify that Bidder is not an Iran-linked business, as that term is defined in the Act. I understand that submission of a false certification may result in contract termination, ineligibility to bid for three (3) years, and a civil penalty of \$250,000 or twice the bid amount, whichever is greater, plus related investigation and legal costs.

Signature

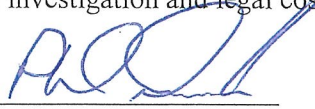

Affidavit of Bidder-Compliance with School Safety Initiative Legislation

The undersigned, the owner or authorized officer of Rolls Mechanical (the "Bidder"), certifies to Midland Public Schools (the "School District"), that any and all persons who will work directly or indirectly for the Bidder, including, but not limited to, Bidder's employees, agents, vendors, subcontractors or consultants, and who will work at or on any School District property, shall at all times be in compliance with MCL 380.1230, 380.1230a, 380.1230c, 380.1230d, and 380.1230g and have not been convicted of any "listed offenses".¹ The Bidder further warrants and represents that all persons who will work directly or indirectly for the Bidder, including, but not limited to, Bidder's employees, agents, vendors, subcontractors or consultants, and who will work at or on any School District property, shall at all times be in compliance with MCL 380.1230, 380.1230a, 380.1230c, 380.1230d, and 380.1230g. In this regard, Bidder agrees, without limitation, to report within 3 business days to the School District when any such person is charged with a crime listed in Section 1535a(1) of the Revised School Code² or a substantially similar law, and to immediately report to the School District if that person is subsequently convicted, plead guilty or plead no contest to that crime.

BIDDER: Rolls Mechanical

By: Phil Dvorak

Its: Est./Proj. Manager

Affidavit of Bidder –Familial Relationships Form

The undersigned, the owner or authorized officer of Rolls Mechanical (the “Bidder”), pursuant to the familial disclosure requirement provided in the Midland Public Schools (the “School District”) advertisement for construction bids, hereby represent and warrant, except as provided below, that no familial relationships exist between the bidder(s) or any employee of Midland Public Schools, and any member of the Board of Education of the School District or the Superintendent of the School District.

List any Familial Relationships:

BIDDER: Rolls Mechanical

By: Phil Dvorak

Its: Est./Proj. Manager

STATE OF MICHIGAN)
)ss.
COUNTY OF Genesee)

This instrument was acknowledged before me on the 11 day of March, 2026, by Phil Dvorak.

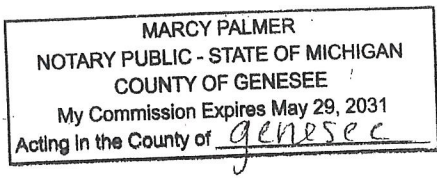

Marcy Palmer, Notary Public
Genesee County, Michigan
My Commission Expires: 5/29/31
Acting in the County of: Genesee

THE AMERICAN INSTITUTE OF ARCHITECTS



AIA Document A310

Bid Bond

KNOW ALL MEN BY THESE PRESENTS, that we

L.J. Rolls Refrigeration Co. dba Rolls Mechanical
1490 Torrey Road, Fenton, MI 48430

as Principal, hereinafter called Principal, and

Old Republic Insurance Company
631 Excel Drive, Suite 200, Mt. Pleasant, PA 15666

a corporation duly organized under the laws of the State of **Pennsylvania**
as Surety, hereinafter called Surety, are held and firmly bound unto

Midland Public Schools
600 E. Carpenter St., Midland, MI 48640

as Obligee, hereinafter called Obligee, in the sum of **Five Percent of Accompanying Bid**

Dollars (5% of Bid)
for the payment of which sum well and truly to be made, the said Principal and the said Surety, bind ourselves, our heirs, executors, administrators, successors and assigns, jointly and severally, firmly by these presents.

WHEREAS, the Principal has submitted a bid for _____ (Here insert full name, address and description of project)

Dow High School Freezer/Cooler Replacement

NOW, THEREFORE, if the Obligee shall accept the bid of the Principal and the Principal shall enter into a Contract with the Obligee in accordance with the terms of such bid, and give such bond or bonds as may be specified in the bidding or Contract Documents with good and sufficient surety for the faithful performance of such Contract and for the prompt payment of labor and material furnished in the prosecution thereof, or in the event of the failure of the Principal to enter such Contract and give such bond or bonds, if the Principal shall pay to the Obligee the difference not to exceed the penalty hereof between the amount specified in said bid and such larger amount for which the Obligee may in good faith contract with another party to perform the Work covered by said bid, then this obligation shall be null and void, otherwise to remain in full force and effect.

Signed and sealed this 12th day of March, 2026.

L.J. Rolls Refrigeration Co. dba Rolls Mechanical

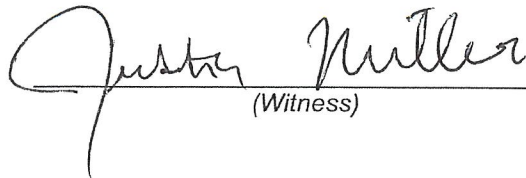
(Witness)

{ _____ (Principal) (Seal)

(Title) **Proj Manager**

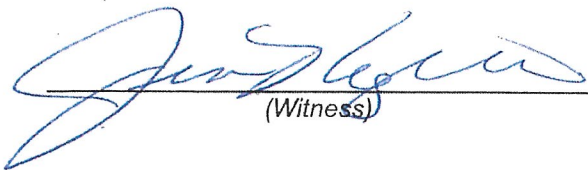
(Witness)

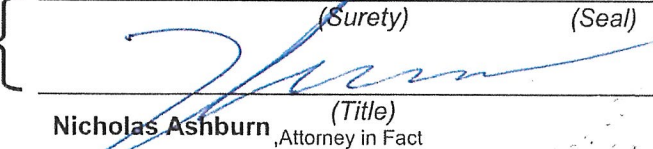
{ **Old Republic Insurance Company**
(Surety) (Seal)

(Title)
Nicholas Ashburn, Attorney in Fact

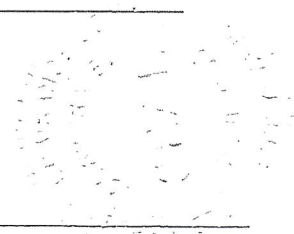



OLD REPUBLIC INSURANCE COMPANY

POWER OF ATTORNEY

KNOW ALL MEN BY THESE PRESENTS: That OLD REPUBLIC INSURANCE COMPANY, a Pennsylvania stock insurance corporation, does make, constitute and appoint:

Michael D. Lechner, Robert D. Heuer, Mark T. Madden, Holly Nichols, Nicholas Ashburn, Jason Rogers
of Rochester, MI

its true and lawful Attorney(s)-in-Fact, with full power and authority for and on behalf of the Company as surety, to execute and deliver and affix the seal of the Company thereto (if a seal is required), bonds, undertakings, recognizances or other written obligations in the nature thereof, (other than self-insurance workers compensation bonds guaranteeing payment of benefits, or black lung bonds), as follows:

ALL WRITTEN INSTRUMENTS

and to bind OLD REPUBLIC INSURANCE COMPANY thereby, and all of the acts of said Attorneys-in-Fact, pursuant to these presents, are ratified and confirmed. This appointment is made under and by authority of the board of directors at a meeting held on December 10, 2019. This Power of Attorney is signed and sealed by facsimile under and by the authority of the following resolutions adopted by the board of directors of the OLD REPUBLIC INSURANCE COMPANY on December 10, 2019.

RESOLVED FURTHER, that the chairman, president or any vice president of the Company's surety division, in conjunction with the secretary or any assistant secretary of the Company, be and hereby are authorized and directed to execute and deliver, to such persons as such officers of the Company may deem appropriate, Powers of Attorney in the form presented to and attached to the minutes of this meeting, authorizing such persons to execute and deliver and affix the seal of the Company to bonds, undertakings, recognizances, and suretyship obligations of all kinds, other than bail bonds, bank depository bonds, mortgage deficiency bonds, mortgage guaranty bonds, guarantees of installment paper and not guaranty bonds. The said officers may revoke any Power of Attorney previously granted to any such person.

RESOLVED FURTHER that any bond, undertaking, recognizance, or suretyship obligation shall be valid and binding upon the Company

- (i) when signed by chairmen, president or any vice president of the Company's surety division and attested and sealed (if a seal be required) by any secretary or assistant secretary; or
- (ii) when signed by a duly authorized Attorney-in-Fact and sealed with the seal of the Company (if a seal be required).

RESOLVED FURTHER, that the signature of any officer designated above, and the seal of the Company, may be affixed by facsimile to any Power of Attorney or certification thereof authorizing the execution and delivery of any bond, undertaking, recognizance, or other suretyship obligations of the Company, and such signature and seal when so used shall have the same force and effect as though manually affixed.

IN WITNESS WHEREOF, OLD REPUBLIC INSURANCE COMPANY has caused these presents to be signed by its proper officer, and its corporate seal to be affixed this 20th day of June, 2024.

Karen J. Haffner
Assistant Secretary



OLD REPUBLIC INSURANCE COMPANY

Alan Pavlic
Vice President

STATE OF WISCONSIN, COUNTY OF WAUKESHA - SS

On this 20th day of June, 2024, personally came before me, Alan Pavlic and Karen J. Haffner, to me known to be the individuals and officers of the OLD REPUBLIC INSURANCE COMPANY who executed the above instrument, and they each acknowledged the execution of the same, and being by me duly sworn, did severally depose and say: that they are the said officers of the corporation aforesaid, and that the seal affixed to the above instrument is the seal of the corporation, and that said corporate seal and their signatures as such officers were duly affixed and subscribed to the said instrument by the authority of the board of directors of said organization.



Kathryn R. Pearson
Notary Public

My Commission Expires: September 28, 2026

CERTIFICATE

(Expiration of notary's commission does not invalidate this instrument)

I, the undersigned, assistant secretary of the OLD REPUBLIC INSURANCE COMPANY, a Pennsylvania corporation, CERTIFY that the foregoing and attached Power of Attorney remains in full force and has not been revoked; and furthermore, that the Resolutions of the board of directors set forth in the Power of Attorney, are now in force.



46-5332

ORSC 11008 (6-93)

Guy Hurley Insurance & Surety Services

Signed and sealed at the City of Brookfield, WI this 12th day of March, 2026.

Karen J. Haffner
Assistant Secretary



Gamshelving® Elements XTRA Series

Stationary Starter & Add-On Units 4 or 5 Vented Shelves

HEIGHT	DEPTHS	LENGTHS	
1	3	8	
64"	18" 21" 24"	24" 30" 36" 42"	48" 54" 60" 72"

- **Starter Units include:**
2 factory assembled post kits, 8 or 10 shelf traverses, traverse dovetails and shelf plates.
- **Add-On Units include:**
1 factory assembled post kit, 8 or 10 shelf traverses, traverse dovetails and shelf plates.

All units ship complete in 1 box.



Features & Benefits

- Designed to easily support the performance demands of a busy foodservice operation with medium to heavy storage needs.
- Use in walk-in coolers, freezers, dry storage, warewashing areas, loading docks or front of the house. Withstands storage temperatures -36° to 190°F (-38° to 88°C). Impervious to moisture, chemicals, salt, food acids and humidity.
- Posts and traverses are made of a revolutionary, extremely strong composite material with a smooth, easy to clean surface. Stronger than common wire shelving and lighter in weight than Camshelving Premium Series. Traverse dovetails are separate from the posts and attach easily to secure the shelf traverses.
- Smooth polypropylene shelf plates contain Camguard, an antimicrobial technology that inhibits the growth of mold, fungus and bacteria that may cause odors, stains and product degradation.
- Shelving Units interconnect in straight lines with shared posts. Uniquely engineered Post Connectors offer exceptional cross stabilization. Weight bearing is uncompromised and space is maximized. No add-on clips or "S" hooks required.
- Easily install heavy-duty Corner Connectors (front and back clasp design) to add shelves in corners or to install middle shelves between 2 units without any loss of weight bearing. Maximizes usable and easy to access storage space.
- Posts and traverses wipe clean. Traverses and shelf plates remove easily for cleaning.
- Shelf traverses can be removed and adjusted at 4" (10,2 cm) increments.
- Sturdy reinforced nylon foot adjusts easily to level units.
- Requires some assembly with minimal parts. Use a rubber mallet only.
- Lifetime warranty against rust and corrosion (posts, traverses and shelf plates).
- Available in 1 color – Speckled Gray (480).

Project _____
 Item No. _____
 Model No. _____
 Quantity _____



Stationary Starter Unit



Stationary Starter and Add-On Unit

WEIGHT BEARING CAPACITY

Weight must be evenly distributed across the entire shelf.

		UNIT LENGTH 24" – 60"	UNIT LENGTH 72"
SINGLE UNIT	Unit only	2400 lbs.	2400 lbs.
	Shelf only	800	600
	Unit with dunnage stand*	2800	2700
	Bottom shelf with dunnage stand*	1200	900

		UNIT LENGTH 24" – 60"	
CORNER UNIT With 2 Dunnage Stands required	Unit only	2400	—
	Shelf only	800	—
	Bottom shelf with dunnage stands*	1200	—

		UNIT LENGTH 24" – 60"	
INTERMEDIATE SHELVES Shelves Installed Between 2 Units	Unit only	2400	—
	Shelf only	800	—
	Bottom shelf with dunnage stands*	1200	—

*Dunnage Stands add stability and increase weight bearing capacity on bottom shelf only. Add to any shelf length. Highly recommended for Starter Units 54" (1375 mm) and longer, all Corner Units, U-Shape Units and units specified for heavier loads.

Approvals



Post Connectors, Corner Connectors, Floor Fastener, Wall Fastener, Identification Tags, Shelf Rails, Single Shelf Security Cage, Peg Board and Shelf Divider Bars are not NSF listed.



www.cambro.com

Information and specifications are subject to change without notice. Please confirm at time of order.

Telephone: (714) 848-1555 Toll Free: (800) 854-7631 Customer Service: (800) 833-3003

© Cambro Manufacturing Company Huntington Beach, California 92647

Printed in U.S.A. 09/23

Camshelving® Elements XTRA Series

Stationary Starter & Add-On Units
4 or 5 Vented Shelves

Project _____
Item No. _____
Model No. _____
Quantity _____

V4

4-Shelf Vented Units

Starter

Add-On

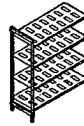
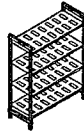

64"
HEIGHT

18"
DEPTH

LENGTH	CODE
24"	EXU182464V4
30"	EXU183064V4
36"	EXU183664V4
42"	EXU184264V4
48"	EXU184864V4
54"	EXU185464V4
60"	EXU186064V4
72"	EXU187264V4

LENGTH	CODE
22"	EXA182464V4
28"	EXA183064V4
34"	EXA183664V4
40"	EXA184264V4
46"	EXA184864V4
52"	EXA185464V4
58"	EXA186064V4
70"	EXA187264V4

21"
DEPTH

LENGTH	CODE
24"	EXU212464V4
30"	EXU213064V4
36"	EXU213664V4
42"	EXU214264V4
48"	EXU214864V4
54"	EXU215464V4
60"	EXU216064V4
72"	EXU217264V4

LENGTH	CODE
22"	EXA212464V4
28"	EXA213064V4
34"	EXA213664V4
40"	EXA214264V4
46"	EXA214864V4
52"	EXA215464V4
58"	EXA216064V4
70"	EXA217264V4

24"
DEPTH

LENGTH	CODE
24"	EXU242464V4
30"	EXU243064V4
36"	EXU243664V4
42"	EXU244264V4
48"	EXU244864V4
54"	EXU245464V4
60"	EXU246064V4
72"	EXU247264V4

LENGTH	CODE
22"	EXA242464V4
28"	EXA243064V4
34"	EXA243664V4
40"	EXA244264V4
46"	EXA244864V4
52"	EXA245464V4
58"	EXA246064V4
70"	EXA247264V4

Color: Speckled Gray (480).

V5

5-Shelf Vented Units

Starter

Add-On

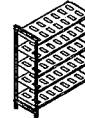
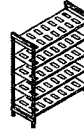

LENGTH	CODE
24"	EXU182464V5
30"	EXU183064V5
36"	EXU183664V5
42"	EXU184264V5
48"	EXU184864V5
54"	EXU185464V5
60"	EXU186064V5
72"	EXU187264V5

LENGTH	CODE
22"	EXA182464V5
28"	EXA183064V5
34"	EXA183664V5
40"	EXA184264V5
46"	EXA184864V5
52"	EXA185464V5
58"	EXA186064V5
70"	EXA187264V5

LENGTH	CODE
24"	EXU212464V5
30"	EXU213064V5
36"	EXU213664V5
42"	EXU214264V5
48"	EXU214864V5
54"	EXU215464V5
60"	EXU216064V5
72"	EXU217264V5

LENGTH	CODE
22"	EXA212464V5
28"	EXA213064V5
34"	EXA213664V5
40"	EXA214264V5
46"	EXA214864V5
52"	EXA215464V5
58"	EXA216064V5
70"	EXA217264V5

LENGTH	CODE
24"	EXU242464V5
30"	EXU243064V5
36"	EXU243664V5
42"	EXU244264V5
48"	EXU244864V5
54"	EXU245464V5
60"	EXU246064V5
72"	EXU247264V5

LENGTH	CODE
22"	EXA242464V5
28"	EXA243064V5
34"	EXA243664V5
40"	EXA244264V5
46"	EXA244864V5
52"	EXA245464V5
58"	EXA246064V5
70"	EXA247264V5

Optional Accessories

- Corner Connector Sets
- Bottom Shelf Dunnage Stands (Low or Tall)
- Shelf Identification Tags
- Wall Fastener
- Floor Fastener
- Shelf Divider Panel
- Shelf Divider Bars (Straight or Angled)
- Single Shelf Sheet Pan Rack
- Single Shelf Security Cage
- Shelf Traverses (Single or Double)
- Drying and Storage Cradles
- Shelf Rails
- Universal Storage Rack
- Single and Add-on Can Racks

Architect Specs

Posts and Traverses: Proprietary non-corrosive composite material.
Post Connectors: Reinforced polypropylene.
Shelf Plates: Reinforced polypropylene with Camguard® antimicrobial.
Corner Connectors: Reinforced nylon.
Adjustable Foot: Reinforced nylon.
Traverse Dovetails: Reinforced nylon.
Post Connector Collar Wedge: Reinforced nylon.

Approvals



Post Connectors, Corner Connectors, Floor Fastener, Wall Fastener, Identification Tags, Shelf Rails, Single Shelf Security Cage, Peg Board and Shelf Divider Bars are not NSF listed.

CAMBRO

www.cambro.com

Information and specifications are subject to change without notice. Please confirm at time of order.

Telephone: (714) 848-1555 Toll Free: (800) 854-7631 Customer Service: (800) 833-3003

© Cambro Manufacturing Company Huntington Beach, California 92647

Printed in U.S.A. 09/23

EXCS1

D082307

Bid Form

Total Pricing to Include Labor and Materials \$75,715.⁰⁰

Please Describe Scope of Work to Include Time Frame of Work

Lead time of box is 4 weeks from time of order.
Removal of old box and equipment and installation of
new box and equipment. 4 year extended warranty included
Will need to do a thorough measurement before ordering
new box. Description of box included. Box Brand is
American Cooler.

Company Refrigeration & Mechanical Services

Title Manager

Email Address Troy@RMS-Pros.com

Phone 616-350-9175

My signature certifies that the proposal as submitted complies with all Terms and Conditions as set forth in this RFP.

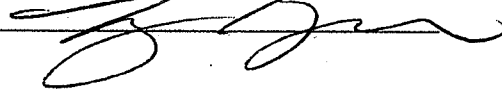
Signature 

1	<u>Indoor Walk-In Cooler / Freezer Combination 9'9" x 20'9" x 8' (OD) With Floor:</u>	
Cooler	<u>9'9" x 8'4" x 8' (OD) With Floor</u>	
Freezer	<u>9'9" x 12'7" x 8' (OD) With Floor</u>	
<u>NSF APPROVED, HIGH DENSITY RAIL CONSTRUCTION USING POLYURETHANE INSULATION</u>		
	<u>Panel Thickness:</u>	3-1/2" Thick Cooler Panels / 5" Thick Freezer Panels
	<u>Panel Finish Interior:</u>	Stucco Galvanized
	<u>Panel Finish Exterior:</u>	Stucco Galvanized
	<u>Ceiling Panels:</u>	Cam Down
		<i>5" Thick Ceiling Panels, Rated for 20 Lbs. Per Sq. Ft.</i>
	<u>Insulated Modular Floor:</u>	Super Floor - Cooler and Freezer, Finished With Smooth Aluminum, 5 Inches Tall
		<i>Rated for 1,200 Lbs. Per Sq. Ft.</i>

Accessories

2	<u>4' LED Light:</u>	4 Foot Long LED Light
2	<u>Light Switch:</u>	W / Pilot Light
2	<u>Thermometer:</u>	2" Diameter Dial Thermometer
2	<u>Pressure Vent:</u>	Heated and Non-Heated Vents
1	<u>Insulated Clr. Door 36 x 84:</u>	w/ Keyed Locking Latch. All Hardware Mounted at Manufacturing Facility
1	<u>Insulated Fzr. Door 36 x 84:</u>	w/ Keyed Locking Latch, All Hardware Mounted at Manufacturing Facility
2	<u>Spring Action Door Closer:</u>	Installed at Factory
1	<u>Heater Cable:</u>	Installed on Freezer Door and Jamb
2	<u>Kickplates:</u>	36 Inch High Aluminum Tread Kickplate on Interior/Exterior
2	<u>Strip Curtain:</u>	(1) Low-Temp Strip Curtain, (1) NT-Strip Curtain, Clear Vinyl Strips, W/Mounting Hardware

Note* Floor is being recessed 5"

NSF approved commercial wire shelving is available in chrome for dry storage or epoxy-coated green for refrigerated storage. Our epoxy-coated shelves carry a 10-year warranty against rust and corrosion; making them perfect for walk-in coolers and walk-in freezers. Our wire shelves are an open wire design offering greater light penetration and visibility. The open design of our food service shelving also keeps it lighter for easier adjustments, while promoting better air circulation, and minimizing dust and dirt accumulation. The load capacity is rated for evenly distributed weight. Our weight capacity is 800 lbs on shelves up to 48" long, and 600 lbs for 54" and longer. Maximum load per assembled unit not to exceed 2000 lbs without casters.

Our posts are 1" O.D. 16 gauge round steel tubing with rolled grooves spaced 1" on center along their length. Each post comes with an adjustable leveling foot.

Affidavit of Bidder –Familial Relationships Form

The undersigned, the owner or authorized officer of Refrigeration & Mech. Services (the "Bidder"), pursuant to the familial disclosure requirement provided in the Midland Public Schools (the "School District") advertisement for construction bids, hereby represent and warrant, except as provided below, that no familial relationships exist between the bidder(s) or any employee of Midland Public Schools, and any member of the Board of Education of the School District or the Superintendent of the School District.

List any Familial Relationships:

BIDDER: Refrigeration & Mechanical Services

By: [Signature]
Its: Manager

STATE OF MICHIGAN)
)ss.
COUNTY OF Kent)

This instrument was acknowledged before me on the 9th day of March, 2026, by Troy Braimyer

Jay Zayler
Kent County, Michigan, Notary Public
My Commission Expires: 3/16/2030
Acting in the County of: Kent

TRACY ZAYLER
NOTARY PUBLIC - STATE OF MICHIGAN
COUNTY OF KENT
My Commission Expires March 16, 2030
Acting in the County of Kent

Iran Economic Sanctions Act Certification

I am the Manager (insert title) of Refrigeration & Mechanical Services (insert bidder company name), or I am bidding in my individual capacity ("Bidder"), with authority to submit a binding bid for the demo, purchase and installation of a walk in freezer/cooler to Midland Public Schools. I have personal knowledge of the matters described in this Certification, and I am familiar with the Iran Economic Sanctions Act, MCL 129.311, et seq. ("Act"). I am fully aware that the school district will rely on my representations in evaluating bids.

I certify that Bidder is not an Iran-linked business, as that term is defined in the Act. I understand that submission of a false certification may result in contract termination, ineligibility to bid for three (3) years, and a civil penalty of \$250,000 or twice the bid amount, whichever is greater, plus related investigation and legal costs.

Signature

A handwritten signature in black ink, appearing to be a stylized name, written over a horizontal line.

Affidavit of Bidder-Compliance with School Safety Initiative Legislation

The undersigned, the owner or authorized officer of Refrigeration & Mech. Services (the "Bidder"), certifies to Midland Public Schools (the "School District"), that any and all persons who will work directly or indirectly for the Bidder, including, but not limited to, Bidder's employees, agents, vendors, subcontractors or consultants, and who will work at or on any School District property, shall at all times be in compliance with MCL 380.1230, 380.1230a, 380.1230c, 380.1230d, and 380.1230g and have not been convicted of any "listed offenses".¹ The Bidder further warrants and represents that all persons who will work directly or indirectly for the Bidder, including, but not limited to, Bidder's employees, agents, vendors, subcontractors or consultants, and who will work at or on any School District property, shall at all times be in compliance with MCL 380.1230, 380.1230a, 380.1230c, 380.1230d, and 380.1230g. In this regard, Bidder agrees, without limitation, to report within 3 business days to the School District when any such person is charged with a crime listed in Section 1535a(1) of the Revised School Code² or a substantially similar law, and to immediately report to the School District if that person is subsequently convicted, plead guilty or plead no contest to that crime.

BIDDER: Refrigeration & Mechanical Services

By: _____

Its: Manager

Bid Form

Total Pricing to Include Labor and Materials \$ 125,000.00

Please Describe Scope of Work to Include Time Frame of Work

CHANGE OUT WALK-IN FREEZER COOLER
COMBO.

Company JOHNSON+WOOD MECHANICAL

Title SERVICE MANAGER

Email Address STEW@JOHNSONWOOD LLC.COM

Phone 989-670-2547

My signature certifies that the proposal as submitted complies with all Terms and Conditions as set forth in this RFP.

Signature 

Affidavit of Bidder –Familial Relationships Form

The undersigned, the owner or authorized officer of JOHNSON WOOD (the "Bidder"), pursuant to the familial disclosure requirement provided in the MIDLAND (the "School District") advertisement for construction bids, hereby represent and warrant, except as provided below, that no familial relationships exist between the bidder(s) or any employee of MIDLAND, and any member of the Board of Education of the School District or the Superintendent of the School District.

List any Familial Relationships:

BIDDER: JOHNSON + WOOD

By: ASEW

Its: SERVICE MANAGER

STATE OF MICHIGAN)
)ss.
COUNTY OF Saginaw)

This instrument was acknowledged before me on the 11th day of March, 2026, by

[Signature]
_____, Notary Public
Saginaw County, Michigan
My Commission Expires: May 14th 2031
Acting in the County of: midland

KIMBERLIE WRIGHT
NOTARY PUBLIC - STATE OF MICHIGAN
COUNTY OF SAGINAW
My Commission Expires May, 14th 2031
Acting in the County of Saginaw

Iran Economic Sanctions Act Certification

I am the SERVILG MABER (insert title) of JOHNSON WOOD (insert bidder company name), or I am bidding in my individual capacity ("Bidder"), with authority to submit a binding bid for the demo, purchase and installation of a walk in freezer/cooler to Midland Public Schools. I have personal knowledge of the matters described in this Certification, and I am familiar with the Iran Economic Sanctions Act, MCL 129.311, et seq. ("Act"). I am fully aware that the school district will rely on my representations in evaluating bids.

I certify that Bidder is not an Iran-linked business, as that term is defined in the Act. I understand that submission of a false certification may result in contract termination, ineligibility to bid for three (3) years, and a civil penalty of \$250,000 or twice the bid amount, whichever is greater, plus related investigation and legal costs.

Signature 

Affidavit of Bidder-Compliance with School Safety Initiative Legislation

The undersigned, the owner or authorized officer of JOHNSON WOOD LLC (the "Bidder"), certifies to Midland Public Schools (the "School District"), that any and all persons who will work directly or indirectly for the Bidder, including, but not limited to, Bidder's employees, agents, vendors, subcontractors or consultants, and who will work at or on any School District property, shall at all times be in compliance with MCL 380.1230, 380.1230a, 380.1230c, 380.1230d, and 380.1230g and have not been convicted of any "listed offenses".¹ The Bidder further warrants and represents that all persons who will work directly or indirectly for the Bidder, including, but not limited to, Bidder's employees, agents, vendors, subcontractors or consultants, and who will work at or on any School District property, shall at all times be in compliance with MCL 380.1230, 380.1230a, 380.1230c, 380.1230d, and 380.1230g. In this regard, Bidder agrees, without limitation, to report within 3 business days to the School District when any such person is charged with a crime listed in Section 1535a(1) of the Revised School Code² or a substantially similar law, and to immediately report to the School District if that person is subsequently convicted, plead guilty or plead no contest to that crime.

BIDDER: JOHNSON+WOOD MECHANICAL

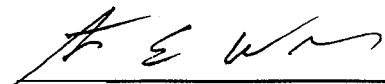
By: 

Its: SERVICE MANAGER



REQUEST FOR PROPOSAL
DEMO OF EXISTING WALK-IN FREEZER/COOLER
INSTALLATION OF NEW WALK-IN FREEZER/COOLER WITH
FLOOR AT
HERBERT HENRY DOW HIGH SCHOOL

Closing Time for Accepting Proposals
Thursday March 12, 2026, 2:00 PM

All bids must be submitted on the attached bid form and signed by the bidder. Two (2) copies of the bid form should be addressed to the attention of:

Midland Public Schools Board of Education
Dow High Walk-In Freezer/Cooler Proposal
600 E. Carpenter St.
Midland, MI 48640

Bids will be opened and read aloud for presentation to the Board of Education at their next regularly scheduled meeting. No oral, telephonic, emailed or facsimile proposals will be considered. NO proposals will be considered after the time of closing of bids.

SCOPE OF WORK:

1. Demo and removal of existing walk-in freezer/cooler
2. The purchase and delivery of a Thermo-Kool® walk in cooler/freezer or equivalent manufacture and specifications.
3. Setup and installation of freezer/cooler to include condensers.
4. All electrical, mechanical, and plumbing associated with installation.

Specifications:

1 ea **Walk In Combination Cooler Freezer**

Thermo-Kool

THERMO-KOOL Walk-in Cooler/Freezer

Dimensions to match existing Walk-in

Insulation: 4" DURATHANE, all-urethane foamed-in-place (Class 1)

Exterior: Stucco Galvanized

Interior: Stucco Galvanized

Interior Floors: Smooth aluminum with foamed in 3/4" Plywood

Cooler, Freezer with 5 inch Floor - recessed by 5"

(2) Match Existing Flush Mounted Entrance Door(s), with hardware, Pilot light & switch assembly, vapor proof light & dial thermometer.

NSF LISTED

(2) Door(s) with (2) Hinges per door

(2) Kason # 1806 LED light fixture at door(s)

(2) 36"H 1/8" Aluminum Treadplate kickplates int & ext

(2) vinyl strip curtain

(2) Pressure relief vent(s)

(2) 48" LED light fixture(s) w/ bulbs

Enclosure panels

Trim

3/4 HP, Remote Pre Assembled Refrig. System Model

RFO080M4SEANT 208-230/60/3 Medium Temperature, base,

weather hood, winter controls, Scroll, Air-cooled, R448A (3.4

Compressor RLA) with RL6A066ADASC 115/60/1 coil (0.8 amps)

with Dual Speed EC motor.

3 1/2 HP, Remote Pre Assembled Refrig. System Model

RFO350L4SEA 208-230/60/3 Low Temperature, base, weather

hood, winter controls, Scroll, Air-cooled, R448A, Std. Defrost Kit

(10.9 Compressor RLA) with RL6E090DDASC 208-230/60/1 coil (1.0

fan amps, 9.8 heater amps) with Dual Speed EC motor.

1 ea WARRANTY 2 Compressor Warranties \$267.75

Installation

Remove existing and installation of new walk-in cooler/freezer combo
Included is running the equipment line set up to 75 foot
horizontal run. Line set anchored and insulated with 3/4 wall
armaflex. Line set brazed and evacuated, system charged with
new R448A. Drain to be within 20 foot gravity feed ran in 3/4
copper.
Install new access panel to match new Walkin.

Any damage to existing Midland Public Schools equipment or property by the contractor will be repaired by the contractor at their own expense. Repairs must meet district approval.

Freezer Shelving

Refer to drawing P-2 for types and location of shelving units. Contractor must include specifications for shelving units and dunnage racks. The following specifications must be followed at a minimum. Size of units may vary to cover both sides of the cooler/freezer.

Dunnage Rack, Parts & Accessories

Cambro Model No. CSDS24H6480
Camshelving® Dunnage Stand Support, fits Premium, original
Elements AND Elements XTRA Series Shelving, 24"W x 6-1/2"H,
recommended for units 54" or longer with weight loads over 600
lbs., speckled gray, NSF listed components

Plastic Shelving Unit

Cambro Model No. EXU244872V4480
Camshelving® Elements XTRA Stationary Starter Unit, 24"W x 48"L
x 72"H, 4-tier, withstands temperature from -36°F (-38°C) to 190°F
(88°C), includes: (4) vented reinforced polypropylene shelf plates
with Camguard® antimicrobial protection, (4) composite posts
with leveling feet installed, pre-assembled post connectors &
wedges, (8) Universal Traverses & (4) bags of 4 dovetails (8 left, 8
right), 800 lbs. capacity per shelf /2,400 lbs. max capacity, speckled
gray, NSF (NOTE: This is a new product line. It is NOT compatible
with original Elements Series products.)

Scope of Work:

1. This is a Request for Proposal for the Demo of the Existing unit, purchase and installation of one walk-in cooler/freezer with floor at H.H Dow High School 3901 N. Saginaw Rd, Midland, Mi 48640.
2. The contractor is responsible for the purchase of any installation materials above and

- beyond what is provided by the manufacturer to safely install specified equipment.
3. The contractor is responsible for the removal of all scraps from demo of the old and the installation of the new Walkin cooler/freezer.
 4. The contractor is responsible for the removal and capping off the existing light fixture as needed.
 5. This is a turnkey installation; cooler/freezer must be fully functioning at the end of installation and signed off by the district before final payment is made.
 6. All mechanical, electrical, and plumbing hook-ups are to meet all State codes and to manufactures specifications.
 7. Contractors must field verify all measurements and meet with the districts representative to clarify all work to be performed.

Contractors Qualifications

Contractor must have five years of experience in this type or similar work.

Guarantee

All materials and equipment, furnished by the Contractor, and all construction involved in this Agreement are hereby guaranteed by the Contractor to be free from defects owing to faulty materials or workmanship for a period of one year after the date of Completion of the work. All work that proves defective, by reason of faulty material or workmanship, within said period of one year, shall be replaced by the Contractor free of cost to the district. These guarantees shall not operate as a waiver of any of the district's rights and remedies for default under or breach of the Agreement which rights and remedies may be exercised at any time within the period of any applicable statute of limitations.

Payment:

The successful bidder will be required to submit a pay application to receive payment. The district will have up to thirty (30) days to submit payment to the contractor for the work completed and materials on site. No materials will be paid for until they are on Midland Public Schools property and confirmed by the district.

Prevailing Wage Requirements

In order to bid on this RFP a contractor must hold a state project registration and any sub-contractor working on this job must also hold a state project registration. The successful contractor is required by law to pay prevailing wage for this job. All documents pertaining to prevailing wage must be processed and the successful contractor must submit pay records for each pay period to the district and to the Michigan Department of Labor and Economic Opportunity. Documentation on prevailing wage for this RFP are included as an attachment. All other prevailing wage laws in the State of Michigan must be adhered to for this contract.

Performance Bond

A Performance Bond by a qualified surety authorized to do business in Michigan in the amount of twenty-five percent (25%) of the Base Bid shall be provided by the successful contractor for each proposal or proposal combination.

Payment Bond

A Payment bond of twenty-five percent (25%) of the Base Bid shall be provided by the successful contractor for each proposal or proposal combination.

Site Visit

Contractors must walk the site to determine the scope of work, equipment and materials needed to satisfy all requirements of this RFP by setting up an appointment with Michael Moeggenberg before the bid opening:

Michael Moeggenberg
Director of Facilities and Operations
Midland Public Schools
989-923-5035
moeggenbergmj@midlandps.org

Safety:

The Contractor shall be responsible for compliance with all applicable federal and state laws, codes, and regulations, including but not limited to MIOSHA and the Right-to-Know.

Fines for MIOSHA Violations:

If the District is assessed any fines for MIOSHA violations arising out of these contract services and attributable to the Contractor, the Contractor shall reimburse the district for these.

Permits:

The contractor is required to obtain and pay for any state and local permits pertaining to this RFP. This is to include all required documentation for Michigan State Plan Review (LARA). The contractor is responsible for sending all the drawings needed through the Michigan State Plan Review. The contractor is responsible for any electrical and mechanical permits.

Insurance Requirements:

The Contractor will provide the district with the required insurance certificates before the Contractor is awarded the contract. These certificates of insurance shall be submitted to the District's Maintenance Department. Once the contract is awarded Midland Public Schools will need to be added as an additional insured to the insurance policies.

Minimum Required Insurance Limits

	Minimum Limits
Commercial General Liability	
Fire Damage	\$100,000
Medical Expenses	\$ 10,000
Personal & Adv. Injury	
Each Occurrence	\$1,000,000
Aggregate \$2,000,000	
Products - Comp/Op Agg.	\$1,000,000
Property Damage	
Each Occurrence	\$1,000,000
Aggregate	\$2,000,000
Excess Liability (Umbrella)	
Each Occurrence	\$5,000,000
Aggregate	\$10,000,000
Fidelity/Employee Dishonesty Bond	\$50,000
Automobile Liability (Including Hired & Non-Owned)	
Personal Injury/Bodily Injury	
Each Occurrence	\$1,000,000
Or Combined Single Limit	\$1,000,000
Property Damage	
Each Occurrence	\$500,000

The Contractor must also provide all of its employees working on this contract with Workers' Compensation insurance. The district will not be responsible for any job-related injuries to the Contractor's employees. Contractor will provide the district with proof of insurance with at least the following coverage limits:

Minimum Limits

Coverage A Statutory

Coverage B as follows:

Each Accident \$500,000

Disease - Policy Limit \$1,000,000

Disease - Each Employee \$500,000

Owners' Rights:

The Board of Education reserves the right to accept or reject any or all item(s) in the bid; to accept or reject any or all bid(s); to waive any informalities therein; or for any reason, to award the contract to other than the low bidder. If a unit price or extended price is obviously in error and the other is obviously correct, the incorrect price will be disregarded.

All bids shall be firm for ninety days (90) from the date of the bid opening. All bids must include a signed "Iran Economic Sanctions Act Certification" a "Familial Relationship Disclosure" form and "Compliance with School Safety Initiative Legislation" (enclosed with RFP documents).

Work Timeline:

The work can start on June 8, 2026, and must be completed by August 14, 2026.

Instruction to Bidders

1. It shall be the bidder's responsibility to read this entire document, review all enclosures and attachment, and comply with all requirements specified within.
2. Bids received after the scheduled opening time will not be accepted.
3. The only bids accepted will be hard copy paper bids.
4. No bid may be withdrawn, changed or modified in any way for a period of ninety (90) calendar days from date of bid opening.
5. Negligence on the part of the bidder in preparing the bid confers no rights for the withdrawal of the bid after it has been opened.
6. Bids received prior to time of opening will be kept securely unopened. No responsibility will be attached to a school district employee who prematurely opens an incorrectly addressed bid proposal.
7. If either a unit price or extended price is obviously in error or the other is obviously correct, the incorrect price will be disregarded.
8. Midland Public Schools is exempt from state and federal taxes.
9. All bids are subject to acceptance by Midland Public Schools Board of Education which reserves the right to accept or reject any or all bids, to split awards by items, to waive irregularities or defects, and accept other than the low bid when deemed to be in the best interest of Midland Public Schools.
10. The laws of the State of Michigan shall govern rights, obligations, and remedies of the Parties under this bid and any agreement reached through this process.

11. All information included in a bid response is subject to the Freedom of Information Act and may be disclosed in its entirety after the formal, public bid opening has been completed.
12. By submission of the proposal, the bidder certifies that the pricing structure offered has been arrived at independently without consultation, communication, or agreement of such prices for the purpose of restricting competition with any other bidder or competitor.
13. The bidder agrees to hold and save Midland Public Schools, its officers, agents, and employees harmless from liability of any kind, including costs and expenses, with respect to any claim, action, cost or judgment for patent, copyright or trademark infringement arising out of the purchase or use of equipment, materials, supplies, or services covered by this bid document.
14. The contractor shall provide items of a minor nature, not specifically noted in this specification, to provide a complete, operable and Owner acceptable service.
15. Contractors are required to comply with the Safety Rules and Accident Prevention plan. The district reserves the right to exclude any worker(s) from the job site(s) for violation of these work rules or any other such offenses deemed inappropriate by the district.
16. The contractor shall clean their job area daily and dispose of all trash and debris leaving the area broom clean. Contractor is responsible for placing a dumpster on site or removing construction materials daily.
17. It is the responsibility of the contractor/bidder to field verify all existing field conditions. Bidders shall inspect the work site and take such steps as may be reasonably necessary to ascertain the nature of the work; and general and local conditions which can affect the work or cost thereof. Failure to do so will not relieve the bidders from responsibility for estimating properly the difficulty or cost of successfully performing the work.
18. The sites are available for your inspections by appointment.

Bid Form

Total Pricing to Include Labor and Materials _____

Please Describe Scope of Work to Include Time Frame of Work

Company _____

Title _____

Email Address _____

Phone _____

My signature certifies that the proposal as submitted complies with all Terms and Conditions as set forth in this RFP.

Signature _____

Iran Economic Sanctions Act Certification

I am the _____ (insert title) of _____ (insert bidder company name), or I am bidding in my individual capacity ("Bidder"), with authority to submit a binding bid for the demo, purchase and installation of a walk in freezer/cooler to Midland Public Schools. I have personal knowledge of the matters described in this Certification, and I am familiar with the Iran Economic Sanctions Act, MCL 129.311, et seq. ("Act"). I am fully aware that the school district will rely on my representations in evaluating bids.

I certify that Bidder is not an Iran-linked business, as that term is defined in the Act. I understand that submission of a false certification may result in contract termination, ineligibility to bid for three (3) years, and a civil penalty of \$250,000 or twice the bid amount, whichever is greater, plus related investigation and legal costs.

Signature _____

Affidavit of Bidder-Compliance with School Safety Initiative Legislation

The undersigned, the owner or authorized officer of _____ (the “Bidder”), certifies to Midland Public Schools (the “School District”), that any and all persons who will work directly or indirectly for the Bidder, including, but not limited to, Bidder’s employees, agents, vendors, subcontractors or consultants, and who will work at or on any School District property, shall at all times be in compliance with MCL 380.1230, 380.1230a, 380.1230c, 380.1230d, and 380.1230g and have not been convicted of any “listed offenses”.¹ The Bidder further warrants and represents that all persons who will work directly or indirectly for the Bidder, including, but not limited to, Bidder’s employees, agents, vendors, subcontractors or consultants, and who will work at or on any School District property, shall at all times be in compliance with MCL 380.1230, 380.1230a, 380.1230c, 380.1230d, and 380.1230g. In this regard, Bidder agrees, without limitation, to report within 3 business days to the School District when any such person is charged with a crime listed in Section 1535a(1) of the Revised School Code² or a substantially similar law, and to immediately report to the School District if that person is subsequently convicted, plead guilty or plead no contest to that crime.

BIDDER: _____

By: _____

Its: _____

Affidavit of Bidder –Familial Relationships Form

The undersigned, the owner or authorized officer of _____ (the “Bidder”), pursuant to the familial disclosure requirement provided in the _____ (the “School District”) advertisement for construction bids, hereby represent and warrant, except as provided below, that no familial relationships exist between the bidder(s) or any employee of _____, and any member of the Board of Education of the School District or the Superintendent of the School District.

List any Familial Relationships:

BIDDER: _____

By: _____

Its: _____

STATE OF MICHIGAN)
)ss.
COUNTY OF _____)

This instrument was acknowledged before me on the _____ day of _____, 2026, by _____.

_____, Notary Public
_____ County, Michigan
My Commission Expires: _____
Acting in the County of: _____



REVISION TABLE	NUMBER	DATE	REVISION BY	DESCRIPTION

H.H. Dow High School
Walk-in Cooler Replacement
3901 N. Saginaw Rd.

DRAWINGS PROVIDED BY:
Midland Public Schools
Facilities Department
989-923-5035

DATE:

2/25/2026

SCALE:

SHEET:

P-1

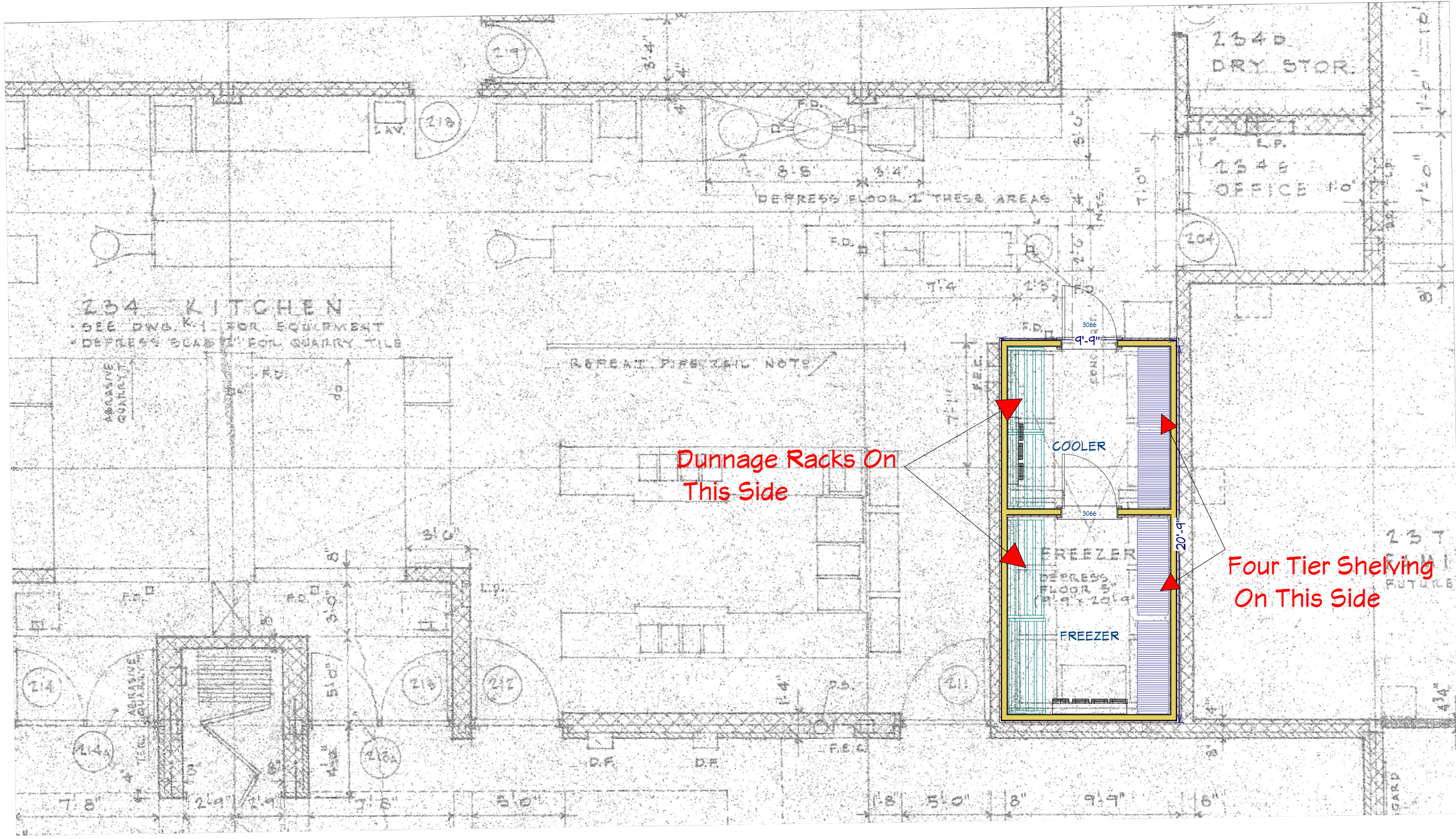

Dunnage Racks On This Side

Four Tier Shelving On This Side

REVISION TABLE	NUMBER	DATE	REVISED BY	DESCRIPTION

H. H Dow High School
Walk-in Cooler Replacement
3901 N. Saginaw Rd.

DRAWINGS PROVIDED BY:
Midland Public Schools
Facilities Department
989-923-5035

DATE:

2/25/2026

SCALE:

SHEET:

P-2

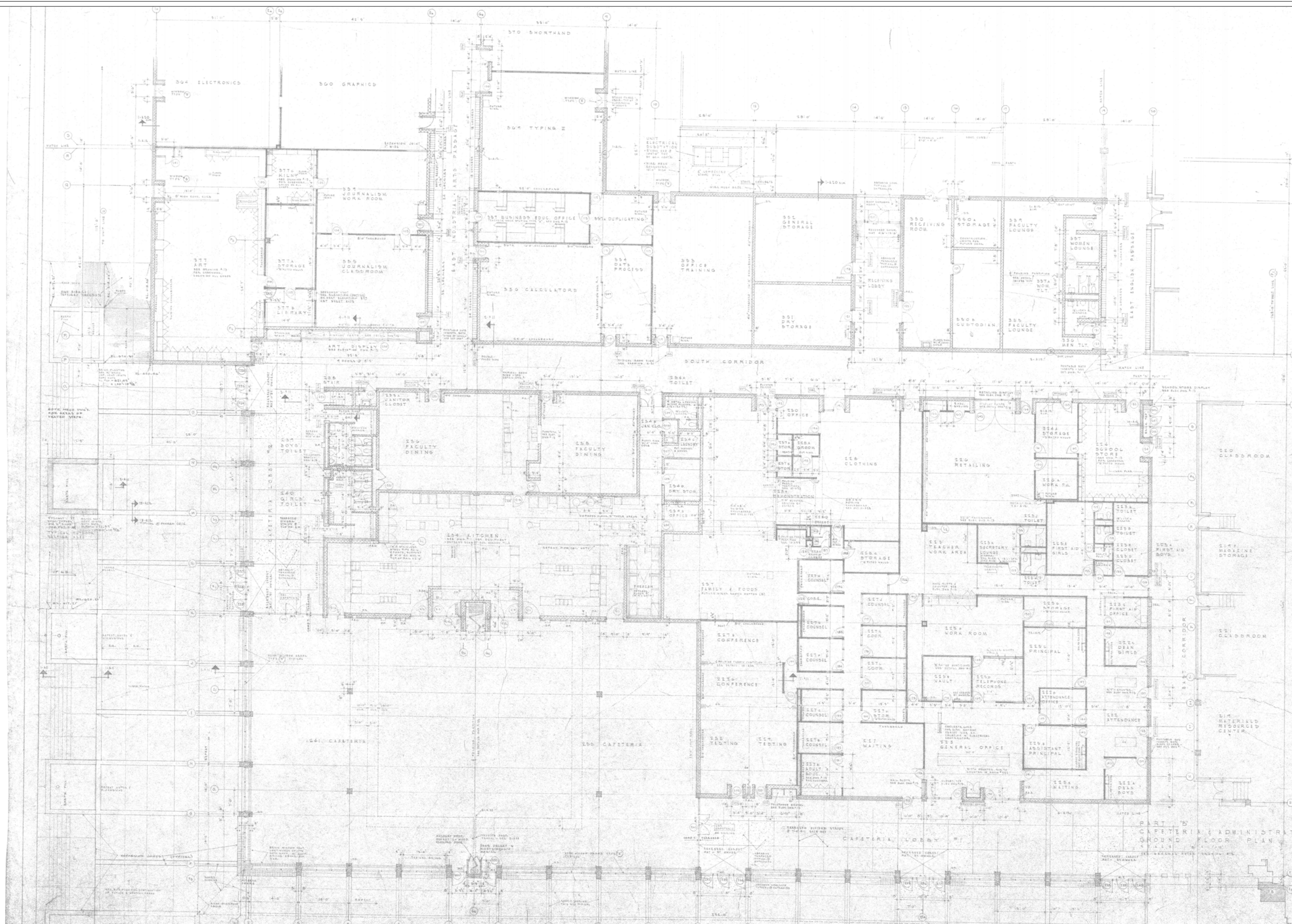

REVISION TABLE	NUMBER	DATE	REVISION BY	DESCRIPTION

H.H. Dow High School
 Walk-in Cooler Replacement
 3901 N. Saginaw Rd.

DRAWINGS PROVIDED BY:
 Midland Public Schools
 Facilities Department
 989-923-5035

DATE:
 2/25/2026

SCALE:
 1/8" = 1'-0"

SHEET:
 P-3

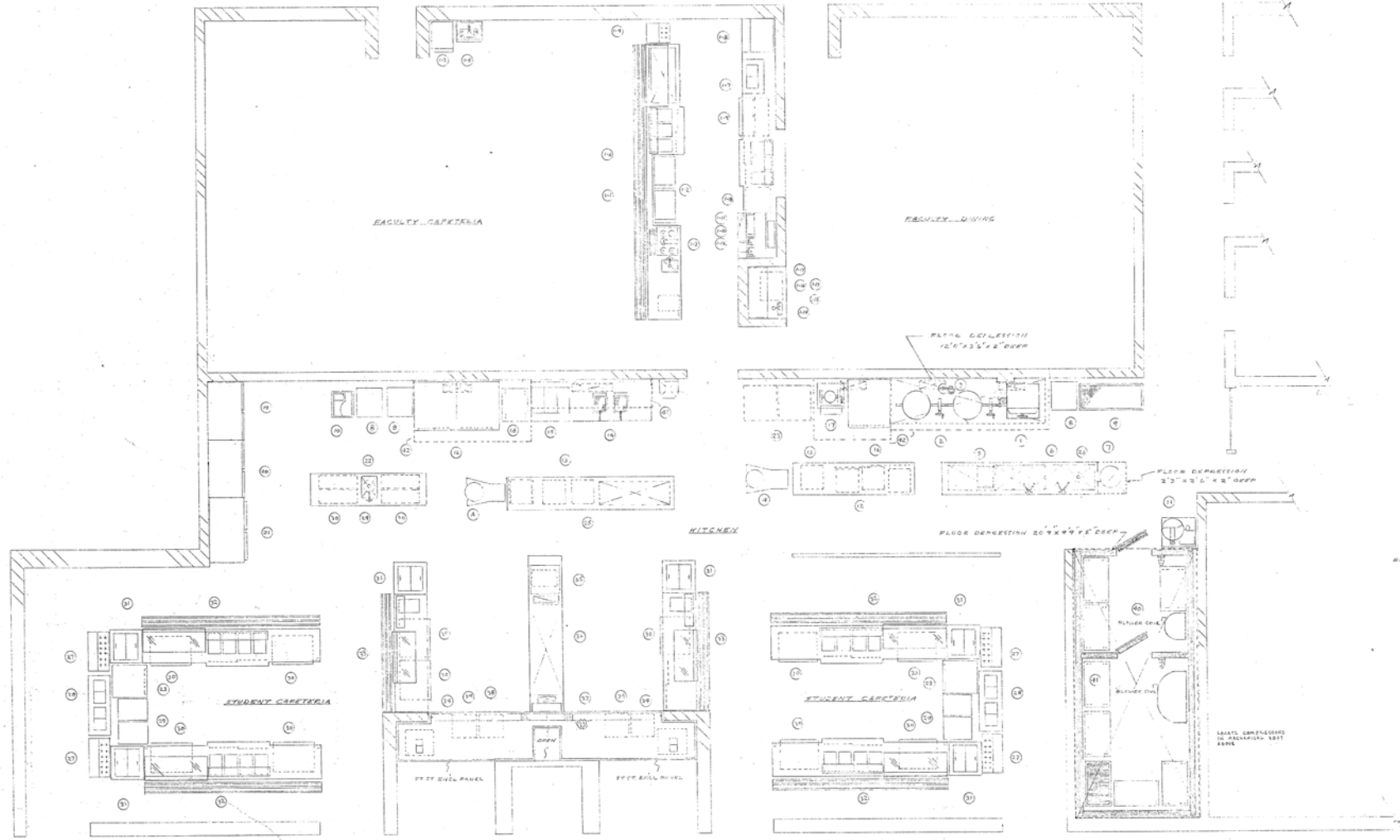

KITCHEN EQUIPMENT FLOOR PLAN
SCALE 3/16"

- KITCHEN EQUIPMENT LIST**
- 1 - STEAM COOKER
 - 2 - STEAM KETTLES
 - 3 - WATER STRAINER
 - 4 - FOOD MIXERS
 - 5 - BOILING HEATER
 - 6 - PAN SINKS
 - 7 - VEGETABLE PEELER
 - 8 - TRAY/PAN RACK
 - 9 - PAN SHELVES
 - 10 - FOOD SLICER/STAND
 - 11 - PASTA CUTTER/STAND
 - 12 - VEGETABLE COUNTER
 - 13 - INCLINING DASH
 - 14 - HOT PLYERS/SPAGHETTI MODULAR
 - 15 - BANQUET STAND - MODULAR
 - 16 - OVENS
 - 17 - STEAM KETTLE/STAND
 - 18 - RICE COOKER
 - 19 - REFRIGERATOR
 - 20 - REFRIGERATOR - W/ELL IN
 - 21 - DISHES
 - 22 - HOT FOOD TRUCKS
 - 23 - SALAD COUNTER
 - 24 - SERVICE COUNTER TABLE
 - 25 - DISHES
 - 26 - TRAY/DISH/WARE CARTS
 - 27 - ICE CLEAN CABINETS
 - 28 - REFRIGERATOR TRAY CARTS
 - 29 - DISH STORAGE CARTS
 - 30 - MILK CABINET
 - 31 - CAFETERIA COUNTER - STAINLESS
 - 32 - ALUMINUM CABINETS - STAINLESS
 - 33 - FLUID COUNT - MODULAR
 - 34 - BOILING HEATER
 - 35 - DISH WASHING/VENTILATED
 - 36 - DISHES
 - 37 - SOIL DISH COUNTER
 - 38 - TRAY/PAN RACK
 - 39 - WALK-IN COOLER/REFRIG
 - 40 - SHELVING - MODULAR
 - 41 - VENTILATING SYSTEM
 - 42 - CAFETERIA COUNTER - FINISHED
 - 43 - UTILITY CARTS
 - 44 - CUPBOARD
 - 45 - TRAY/DISH/WARE CART
 - 46 - WATER STATION
 - 47 - SERVING COUNTER - FINISHED
 - 48 - ICE CLEAN CABINETS
 - 49 - ICE CLEANING
 - 50 - ICE STORAGE CARTS
 - 51 - GRILL STAND/VENTILATED
 - 52 - SERVICE
 - 53 - PAY PHONE
 - 54 - WAITRESS STATION
 - 55 - WATER FOUNTAIN
 - 56 - COFFEE JUV. (NOT SHOWN)
 - 57 - UTILITY CART
 - 58 - TRAY
 - 59 - REFRIG. W/ELL

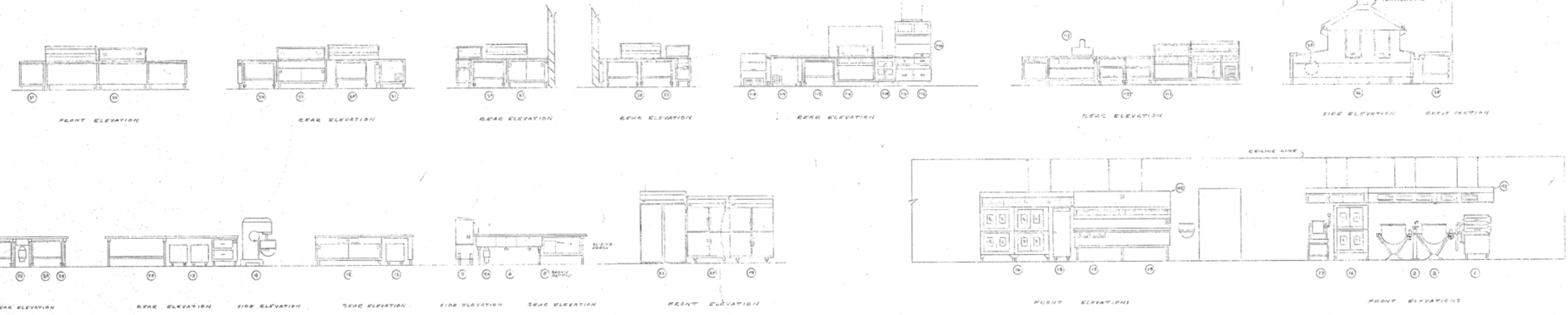
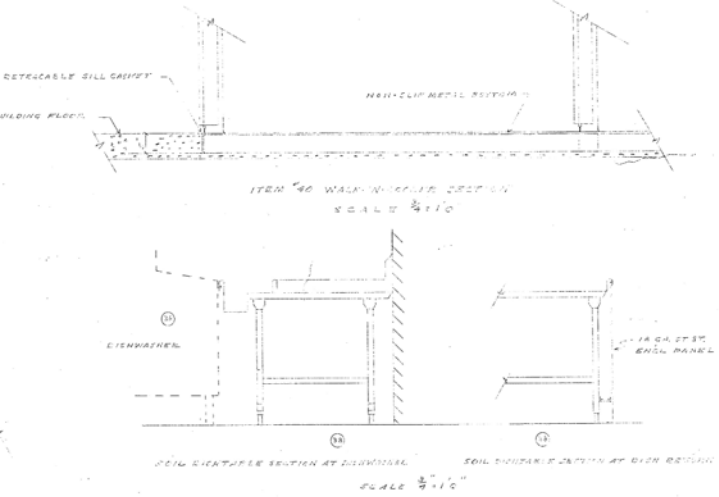

ALDEN B. DOW ASSOCIATES, INC. - ARCHITECT
 ROBERT J. DAVIS - ARCHITECTURAL ENGINEER
 ROBERT J. DAVIS - MECHANICAL ENGINEER
 ROBERT J. DAVIS - ELECTRICAL ENGINEER
 ROBERT J. DAVIS - LANDSCAPE ARCHITECT
 MIDLAND MICHIGAN
 HENRY DOW HIGH SCHOOL
 MIDLAND MICHIGAN
 THE HERBERT MIDLAND MICHIGAN
 KITCHEN EQUIPMENT FLOOR PLAN & ELEVATIONS
 DATE: NOV 11, 1986

NUMBER	DATE	REVISION TABLE	REVISION BY	DESCRIPTION

H. H. Dow High School
Walk-in Cooler Replacement
3901 N. Saginaw Rd.

DRAWINGS PROVIDED BY:
Midland Public Schools
Facilities Department
989-923-5035

DATE: 2/25/2026
SCALE:
SHEET: P-4

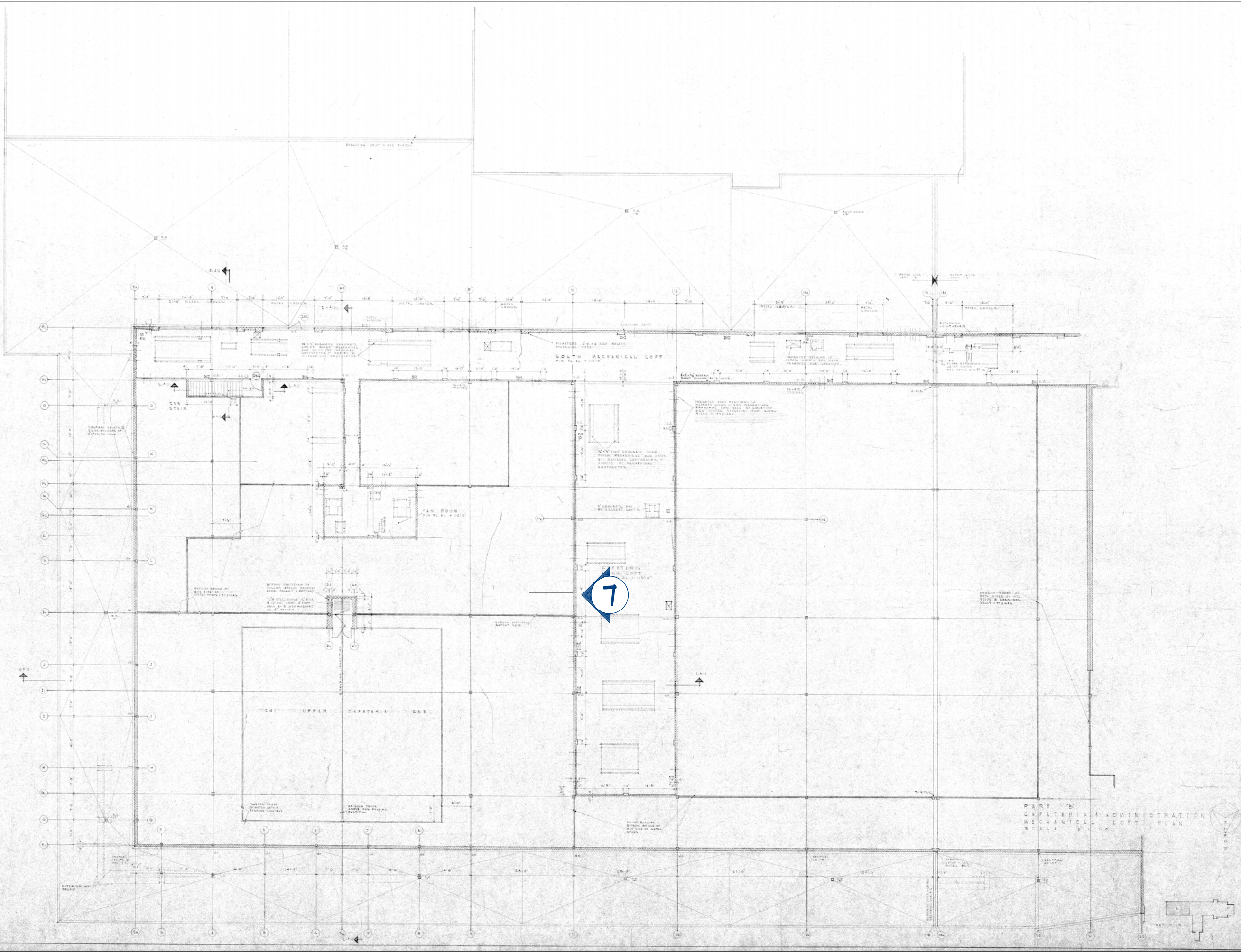

DRAWINGS PROVIDED BY:
Midland Public Schools
 Facilities Department
 989-923-5035

H. H Dow High School
 Walk-In Cooler Replacement
 3901 N. Saginaw Rd.

REVISION TABLE	NUMBER	DATE	REVISION BY	DESCRIPTION

DATE: 2/25/2026
 SCALE:
 SHEET: P-5

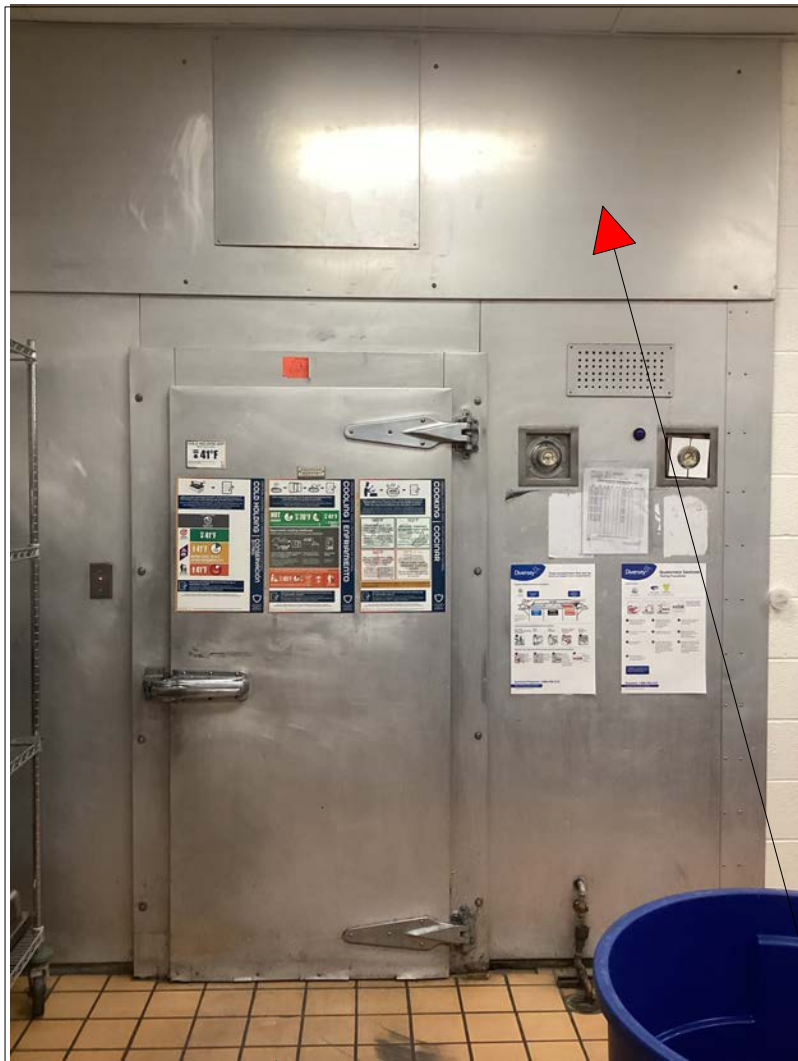

1
P-1



2
P-1



3
P-1

Remove and add new access panel to match new cooler



4
P-1

5
P-1



REVISION TABLE	NUMBER	DATE	REVISOR	DESCRIPTION

H. H Dow High School
Walk-in Cooler Replacement
3901 N. Saginaw Rd.

DRAWINGS PROVIDED BY:
Midland Public Schools
Facilities Department
989-923-5035

DATE:
2/25/2026

SCALE:

SHEET:
P-6

PANELBOARD D. P. 36	
V. PH. DATE:	
FED FROM PANEL	
CIR.	LOAD DESCRIPTION
1	WALK IN Comp. → FAN
2	Mixer
3	Vegetable Peeler
4	WALK IN Comp. + FAN
5	Steam Kettle
6	Booster Heater
7	Deep Fryer East
8	Deep Fryer West
9	Oven
10	
11	Steam Cooker
12	
13	
14	
15	

6
P-1



7
P-5

7
P-5



Top of unit

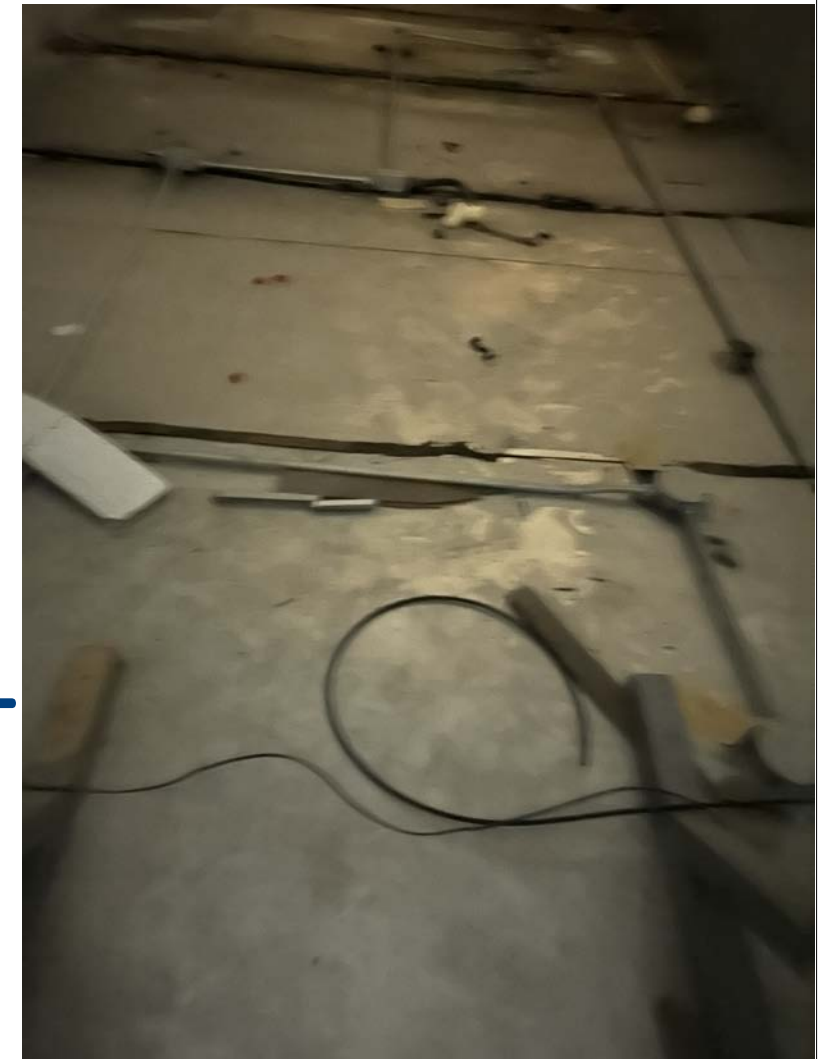

REVISION TABLE			
NUMBER	DATE	REVISION BY	DESCRIPTION

H. H Dow High School
Walk-in Cooler Replacement
3901 N. Saginaw Rd.

DRAWINGS PROVIDED BY:
Midland Public Schools
Facilities Department
989-923-5035

DATE:

2/25/2026

SCALE:

SHEET:

P-7

DOW HIGH WALK IN COOLER BID TALLY SHEET

3/12/26 2pm

COMPANY	Total Pricing	Iran	Familiarization	Safety
Refrigeration and Mechanical Services	\$75,715.00	X	X	X
Rolls Mechanical	\$98,125.00	X	X	X
William E. Walters	\$175,000.00	X	X	X
Johnson and Wood Mechanical	\$125,000.00	X	X	X

9. 3. For Action: Trailer Mounted Cooler (Wamack)

Recommendation

Bids were solicited and a tabulation is provided for a trailer mounted cooler for our food service department. Administration recommends issuing a purchase order to Spencer Trailers of Spencer, IN for \$56,795. Food Service funds will be utilized for this purchase.

Supporting Documents



[Trailer Mounted Cooler Tally](#)



[Trailer Mounted Cooler RFP](#)



[Tiles in Style LLC RFP](#)



[Spencer Trailers RFP](#)



**MIDLAND PUBLIC SCHOOLS REQUEST FOR PROPOSAL FOR
A “New 2025-26 Polar King Mobile PKM Avalanche 6’x 16’
Mobile Refrigerator/Freezer”**

SPECIFICATIONS:

6’ Wide
16’ Long
6’ 6” Interior Height
2- 7000 lb Torsion Axles with EZ Lube Hubs
Electric Brakes
14000 lb GVWR
2 5/16” Coupler
Hydraulic Jack
Drop Deck (Ground Level Loading System)
HD Reinforced Tread Plate Fenders
54” Reinforced Door 4” Thick (R-28) Roof and Walls
564 Cubic Feet Interior Volume
GOVI Arktik 2000US Refrigeration Unit (Super Quiet)
0 to 50 Degree Temperature Range
1 Piece Seamless Fiberglass Construction
Interior Antimicrobial Gel Coating
Trailer is NSF Certified
Side Door with Step
E-Track Installed
LED Strip Lights
Reinforced Ceiling
Custom Cart Floor
ST235/80R16 10-Ply Radial Tires
Matching Spare Tire
Bumper Guards
12V LED Loading Light
110V Charger
4 Amp Trickle Charger

Wireless Remote

Back-Up Lights

All LED Lights

9000 Running Watts 11,500 Peak (District Approved)

Dual Fuel LP and Gas or Quad Fuel Generator Mounted on Front Plate

RECOVR 3 Years GPS Tracking System

- **Temperature Range:** 0°F to 50°F
- **Dimensions:** 6' x 16
- **GVWR:** 14,000
- **Trailer Weight:** 3,200
- **Capacity:** 9,720
- **Features:** E-Track Installed

Note: All equipment must be new 2025 or 2026 model

Vendors Qualifications

Vendor must have 5 years of experience in the sales of trailer mounted walk-in coolers.

Bid Information

Bids will be accepted until 2:00 P.M. local time on March 16, 2026, at which time bids will be opened and read aloud for presentation to the Board of Education at their next regularly scheduled meeting. No oral, telephonic or facsimile proposals will be considered. No proposals will be considered after the time of closing of bids.

Owners Rights

The Board of Education reserves the right to accept or reject any or all item(s) in the bid; to accept or reject any or all bid(s); to waive any informalities therein; or for any reason, to award the contract to other than the low bidder. If a unit price or extended price is obviously in error and the other is obviously correct, the incorrect price will be disregarded.

All bids shall be firm for ninety days (90) from the date of the bid opening. All bids must include a signed "Iran Economic Sanctions Act Certification" a "Familial Relationship Disclosure" form and "Compliance with School Safety Initiative Legislation" (enclosed with documents).

All bids must be submitted on the attached bid form and signed by the bidder. Two (2) copies of the bid form should be addressed to the attention of:

Michael Moeggenberg
Midland Public Schools
600 East Carpenter Street
Midland, Michigan 48640-5417
“Trailer Mounted Walk In Cooler”

One (1) copy of the bid form should be retained for your files. Questions should be referred to Michael Moeggenberg, Director of Facilities and Operations 989-923-5035
moeggenbergmj@midlandps.org

Delivery

Contractor should include delivery timeline on bid form. Vendor will be responsible for insurance of equipment up to the time of district signing off and taking possession of equipment. Delivery to

Midland Public Schools
600 E. Carpenter St
Midland Mi, 48640

Payment

After Midland Public Schools Board of Education approval, the district will issue a purchase order to the successful vendor. Midland Public Schools will issue a check on delivery and inspection of the vehicle if requested by the vendor, or within 14 days of delivery if not requested. Please indicate any changes to this payment requirement on the bid form. Invoice should be submitted to delivery address.

Instruction to Bidders

1. It shall be the bidder's responsibility to read this entire document, review all enclosures and attachment, and comply with all requirements specified within.
2. Bids received after the scheduled opening time will not be accepted.
3. The only bids accepted will be hard copy paper bids.
4. No bid may be withdrawn, changed, or modified in any way for a period of ninety (90) calendar days from date of bid opening.
5. Negligence on the part of the bidder in preparing the bid confers no rights for the withdrawal of the bid after it has been opened.
6. Bids received prior to time of opening will be kept securely unopened. No responsibility will be attached to school district employee who prematurely opens an incorrectly addressed bid proposal.
7. If either a unit price or extended price is obviously in error or the other is obviously correct, the incorrect price will be disregarded.
8. Midland Public Schools is exempt from state and federal taxes.
9. All bids are subject to acceptance by Midland Public Schools Board of Education which reserves the right to accept or reject any or all bids, to split awards by items, to waive irregularities or defects, and accept other than the low bid when deemed to be in the best interest of Midland Public Schools.
10. The laws of the State of Michigan shall govern rights, obligations, and remedies of the Parties under this bid and any agreement reached through this process.
11. All information included in a bid response is subject to the Freedom of Information Act and may be disclosed in its entirety after the formal, public bid opening has been completed.
12. By submission of the proposal, the bidder certifies that the pricing structure offered has been arrived at independently without consultation, communication, or agreement of such prices for the purpose of restricting competition with any other bidder or competitor.
13. The bidder agrees to hold and save Midland Public Schools, its officers, agents, and employees harmless from liability of any kind, including costs and expenses, with respect to any claim, action, cost or judgment for patent, copyright or trademark infringement arising out of the purchase or use of equipment, materials, supplies, or services covered by this bid document.

Bid Form

Trailer/Walk-In Cooler Price _____

Delivery Charges _____

Total Pricing _____

Please describe any changes to include additions and subtractions from bid specifications

Company _____

Title _____

Phone _____

Email _____

My signature certifies that the proposal as submitted complies with all Terms and Conditions as set forth in this RFP.

Signature _____

Iran Economic Sanctions Act Certification

I am the _____ (insert title) of _____ (insert bidder company name), or I am bidding in my individual capacity ("Bidder"), with authority to submit a binding bid for the equipment sale to Midland Public Schools. I have personal knowledge of the matters described in this Certification, and I am familiar with the Iran Economic Sanctions Act, MCL 129.311, et seq. ("Act"). I am fully aware that the school district will rely on my representations in evaluating bids.

I certify that Bidder is not an Iran-linked business, as that term is defined in the Act. I understand that submission of a false certification may result in contract termination, ineligibility to bid for three (3) years, and a civil penalty of \$250,000 or twice the bid amount, whichever is greater, plus related investigation and legal costs.

Signature _____

Affidavit of Bidder-Compliance with School Safety Initiative Legislation

The undersigned, the owner or authorized officer of _____ (the “Bidder”), certifies to Midland Public Schools (the “School District”), that any and all persons who will work directly or indirectly for the Bidder, including, but not limited to, Bidder’s employees, agents, vendors, subcontractors or consultants, and who will work at or on any School District property, shall at all times be in compliance with MCL 380.1230, 380.1230a, 380.1230c, 380.1230d, and 380.1230g and have not been convicted of any “listed offenses”.¹ The Bidder further warrants and represents that all persons who will work directly or indirectly for the Bidder, including, but not limited to, Bidder’s employees, agents, vendors, subcontractors or consultants, and who will work at or on any School District property, shall at all times be in compliance with MCL 380.1230, 380.1230a, 380.1230c, 380.1230d, and 380.1230g. In this regard, Bidder agrees, without limitation, to report within 3 business days to the School District when any such person is charged with a crime listed in Section 1535a(1) of the Revised School Code² or a substantially similar law, and to immediately report to the School District if that person is subsequently convicted, plead guilty or plead no contest to that crime.

BIDDER: _____

By: _____

Its: _____

Example of Equipment



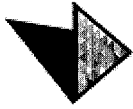

**MIDLAND PUBLIC SCHOOLS REQUEST FOR PROPOSAL FOR
A "New 2025-26 Polar King Mobile PKM Avalanche 6'x 16'
Mobile Refrigerator/Freezer"**

SPECIFICATIONS:

6' Wide
16' Long
6' 6" Interior Height
2- 7000 lb Torsion Axles with EZ Lube Hubs
Electric Brakes
14000 lb GVWR
2 5/16" Coupler
Hydraulic Jack
Drop Deck (Ground Level Loading System)
HD Reinforced Tread Plate Fenders
54" Reinforced Door 4" Thick (R-28) Roof and Walls
564 Cubic Feet Interior Volume
GOVI Arktik 2000US Refrigeration Unit (Super Quiet)
0 to 50 Degree Temperature Range
1 Piece Seamless Fiberglass Construction
Interior Antimicrobial Gel Coating
Trailer is NSF Certified
Side Door with Step
E-Track Installed
LED Strip Lights
Reinforced Ceiling
Custom Cart Floor
ST235/80R16 10-Ply Radial Tires
Matching Spare Tire
Bumper Guards
12V LED Loading Light
110V Charger
4 Amp Trickle Charger

Wireless Remote

Back-Up Lights

All LED Lights

9000 Running Watts 11,500 Peak (District Approved)

Dual Fuel LP and Gas or Quad Fuel Generator Mounted on Front Plate

RECOVER 3 Years GPS Tracking System

- **Temperature Range:** 0°F to 50°F
- **Dimensions:** 6' x 16
- **GVWR:** 14,000
- **Trailer Weight:** 3,200
- **Capacity:** 9,720
- **Features:** E-Track Installed

Note: All equipment must be new 2025 or 2026 model

Vendors Qualifications

Vendor must have 5 years of experience in the sales of trailer mounted walk-in coolers.

Bid Information

Bids will be accepted until 2:00 P.M. local time on March 16, 2026, at which time bids will be opened and read aloud for presentation to the Board of Education at their next regularly scheduled meeting. No oral, telephonic or facsimile proposals will be considered. No proposals will be considered after the time of closing of bids.

Owners Rights

The Board of Education reserves the right to accept or reject any or all item(s) in the bid; to accept or reject any or all bid(s); to waive any informalities therein; or for any reason, to award the contract to other than the low bidder. If a unit price or extended price is obviously in error and the other is obviously correct, the incorrect price will be disregarded.

All bids shall be firm for ninety days (90) from the date of the bid opening. All bids must include a signed "Iran Economic Sanctions Act Certification" a "Familial Relationship Disclosure" form and "Compliance with School Safety Initiative Legislation" (enclosed with documents).

All bids must be submitted on the attached bid form and signed by the bidder. Two (2) copies of the bid form should be addressed to the attention of:

Michael Moeggenberg
Midland Public Schools
600 East Carpenter Street
Midland, Michigan 48640-5417
"Trailer Mounted Walk In Cooler"

One (1) copy of the bid form should be retained for your files. Questions should be referred to Michael Moeggenberg, Director of Facilities and Operations 989-923-5035
moeggenbergmj@midlandps.org

Delivery

Contractor should include delivery timeline on bid form. Vendor will be responsible for insurance of equipment up to the time of district signing off and taking possession of equipment. Delivery to
Midland Public Schools
600 E. Carpenter St
Midland Mi, 48640

Payment

After Midland Public Schools Board of Education approval, the district will issue a purchase order to the successful vendor. Midland Public Schools will issue a check on delivery and inspection of the vehicle if requested by the vendor, or within 14 days of delivery if not requested. Please indicate any changes to this payment requirement on the bid form. Invoice should be submitted to delivery address.

Instruction to Bidders

1. It shall be the bidder's responsibility to read this entire document, review all enclosures and attachment, and comply with all requirements specified within.
2. Bids received after the scheduled opening time will not be accepted.
3. The only bids accepted will be hard copy paper bids.
4. No bid may be withdrawn, changed, or modified in any way for a period of ninety (90) calendar days from date of bid opening.
5. Negligence on the part of the bidder in preparing the bid confers no rights for the withdrawal of the bid after it has been opened.
6. Bids received prior to time of opening will be kept securely unopened. No responsibility will be attached to school district employee who prematurely opens an incorrectly addressed bid proposal.
7. If either a unit price or extended price is obviously in error or the other is obviously correct, the incorrect price will be disregarded.
8. Midland Public Schools is exempt from state and federal taxes.
9. All bids are subject to acceptance by Midland Public Schools Board of Education which reserves the right to accept or reject any or all bids, to split awards by items, to waive irregularities or defects, and accept other than the low bid when deemed to be in the best interest of Midland Public Schools.
10. The laws of the State of Michigan shall govern rights, obligations, and remedies of the Parties under this bid and any agreement reached through this process.
11. All information included in a bid response is subject to the Freedom of Information Act and may be disclosed in its entirety after the formal, public bid opening has been completed.
12. By submission of the proposal, the bidder certifies that the pricing structure offered has been arrived at independently without consultation, communication, or agreement of such prices for the purpose of restricting competition with any other bidder or competitor.
13. The bidder agrees to hold and save Midland Public Schools, its officers, agents, and employees harmless from liability of any kind, including costs and expenses, with respect to any claim, action, cost or judgment for patent, copyright or trademark infringement arising out of the purchase or use of equipment, materials, supplies, or services covered by this bid document.

Bid Form

Trailer/Walk-In Cooler Price	<u>\$90,124.25</u>
Delivery Charges	<u>Included</u>
Total Pricing	<u>\$90,124.25</u>

Please describe any changes to include additions and subtractions from bid specifications

Company Tiles in Style LLC

Title President

Phone 630-473-9004

Email tom@tilesinstyle.com

My signature certifies that the proposal as submitted complies with all Terms and Conditions as set forth in this RFP

Signature 

Iran Economic Sanctions Act Certification

I am the President (insert title) of Tiles in Style LLC (insert bidder company name), or I am bidding in my individual capacity ("Bidder"), with authority to submit a binding bid for the equipment sale to Midland Public Schools. I have personal knowledge of the matters described in this Certification, and I am familiar with the Iran Economic Sanctions Act, MCL 129.311, et seq. ("Act"). I am fully aware that the school district will rely on my representations in evaluating bids.

I certify that Bidder is not an Iran-linked business, as that term is defined in the Act. I understand that submission of a false certification may result in contract termination, ineligibility to bid for three (3) years, and a civil penalty of \$250,000 or twice the bid amount, whichever is greater, plus related investigation and legal costs.

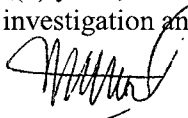
Signature  _____

Affidavit of Bidder-Compliance with School Safety Initiative Legislation

The undersigned, the owner or authorized officer of Tiles in Style LLC (the "Bidder"), certifies to Midland Public Schools (the "School District"), that any and all persons who will work directly or indirectly for the Bidder, including, but not limited to, Bidder's employees, agents, vendors, subcontractors or consultants, and who will work at or on any School District property, shall at all times be in compliance with MCL 380.1230, 380.1230a, 380.1230c, 380.1230d, and 380.1230g and have not been convicted of any "listed offenses".¹ The Bidder further warrants and represents that all persons who will work directly or indirectly for the Bidder, including, but not limited to, Bidder's employees, agents, vendors, subcontractors or consultants, and who will work at or on any School District property, shall at all times be in compliance with MCL 380.1230, 380.1230a, 380.1230c, 380.1230d, and 380.1230g. In this regard, Bidder agrees, without limitation, to report within 3 business days to the School District when any such person is charged with a crime listed in Section 1535a(1) of the Revised School Code² or a substantially similar law, and to immediately report to the School District if that person is subsequently convicted, plead guilty or plead no contest to that crime.

BIDDER: Tiles in Style LLC

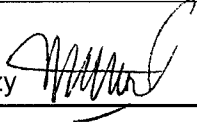
By: Mariam Ezzy 

Its: President

Example of Equipment

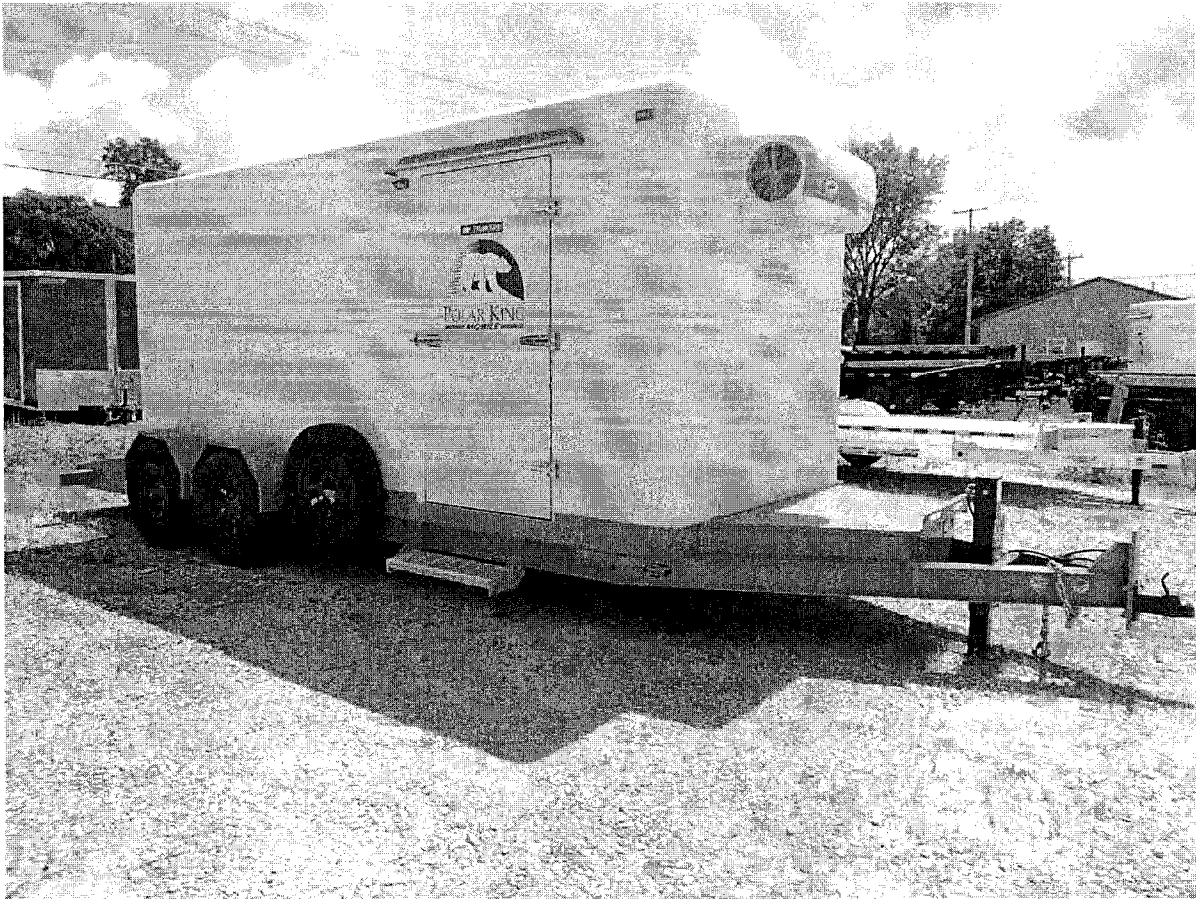

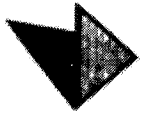

**MIDLAND PUBLIC SCHOOLS REQUEST FOR PROPOSAL FOR
A "New 2025-26 Polar King Mobile PKM Avalanche 6'x 16'
Mobile Refrigerator/Freezer"**

SPECIFICATIONS:

6' Wide
16' Long
6' 6" Interior Height
2- 7000 lb Torsion Axles with EZ Lube Hubs
Electric Brakes
14000 lb GVWR
2 5/16" Coupler
Hydraulic Jack
Drop Deck (Ground Level Loading System)
HD Reinforced Tread Plate Fenders
54" Reinforced Door 4" Thick (R-28) Roof and Walls
564 Cubic Feet Interior Volume
GOVI Arktik 2000US Refrigeration Unit (Super Quiet)
0 to 50 Degree Temperature Range
1 Piece Seamless Fiberglass Construction
Interior Antimicrobial Gel Coating
Trailer is NSF Certified
Side Door with Step
E-Track Installed
LED Strip Lights
Reinforced Ceiling
Custom Cart Floor
ST235/80R16 10-Ply Radial Tires
Matching Spare Tire
Bumper Guards
12V LED Loading Light
110V Charger
4 Amp Trickle Charger

Wireless Remote
Back-Up Lights
All LED Lights
9000 Running Watts 11,500 Peak (District Approved)
Dual Fuel LP and Gas or Quad Fuel Generator Mounted on Front Plate
RECOVR 3 Years GPS Tracking System

- **Temperature Range:** 0°F to 50°F
- **Dimensions:** 6' x 16
- **GVWR:** 14,000
- **Trailer Weight:** 3,200
- **Capacity:** 9,720
- **Features:** E-Track Installed

Note: All equipment must be new 2025 or 2026 model

Vendors Qualifications

Vendor must have 5 years of experience in the sales of trailer mounted walk-in coolers.

Bid Information

Bids will be accepted until 2:00 P.M. local time on March 16, 2026, at which time bids will be opened and read aloud for presentation to the Board of Education at their next regularly scheduled meeting. No oral, telephonic or facsimile proposals will be considered. No proposals will be considered after the time of closing of bids.

Owners Rights

The Board of Education reserves the right to accept or reject any or all item(s) in the bid; to accept or reject any or all bid(s); to waive any informalities therein; or for any reason, to award the contract to other than the low bidder. If a unit price or extended price is obviously in error and the other is obviously correct, the incorrect price will be disregarded.

All bids shall be firm for ninety days (90) from the date of the bid opening. All bids must include a signed "Iran Economic Sanctions Act Certification" a "Familial Relationship Disclosure" form and "Compliance with School Safety Initiative Legislation" (enclosed with documents).

All bids must be submitted on the attached bid form and signed by the bidder. Two (2) copies of the bid form should be addressed to the attention of:

Michael Moeggenberg
Midland Public Schools
600 East Carpenter Street
Midland, Michigan 48640-5417
"Trailer Mounted Walk In Cooler"

One (1) copy of the bid form should be retained for your files. Questions should be referred to Michael Moeggenberg, Director of Facilities and Operations 989-923-5035
moeggenbergmj@midlandps.org

Delivery

Contractor should include delivery timeline on bid form. Vendor will be responsible for insurance of equipment up to the time of district signing off and taking possession of equipment. Delivery to

Midland Public Schools
600 E. Carpenter St
Midland Mi, 48640

Payment

After Midland Public Schools Board of Education approval, the district will issue a purchase order to the successful vendor. Midland Public Schools will issue a check on delivery and inspection of the vehicle if requested by the vendor, or within 14 days of delivery if not requested. Please indicate any changes to this payment requirement on the bid form. Invoice should be submitted to delivery address.

Instruction to Bidders

1. It shall be the bidder's responsibility to read this entire document, review all enclosures and attachment, and comply with all requirements specified within.
2. Bids received after the scheduled opening time will not be accepted.
3. The only bids accepted will be hard copy paper bids.
4. No bid may be withdrawn, changed, or modified in any way for a period of ninety (90) calendar days from date of bid opening.
5. Negligence on the part of the bidder in preparing the bid confers no rights for the withdrawal of the bid after it has been opened.
6. Bids received prior to time of opening will be kept securely unopened. No responsibility will be attached to school district employee who prematurely opens an incorrectly addressed bid proposal.
7. If either a unit price or extended price is obviously in error or the other is obviously correct, the incorrect price will be disregarded.
8. Midland Public Schools is exempt from state and federal taxes.
9. All bids are subject to acceptance by Midland Public Schools Board of Education which reserves the right to accept or reject any or all bids, to split awards by items, to waive irregularities or defects, and accept other than the low bid when deemed to be in the best interest of Midland Public Schools.
10. The laws of the State of Michigan shall govern rights, obligations, and remedies of the Parties under this bid and any agreement reached through this process.
11. All information included in a bid response is subject to the Freedom of Information Act and may be disclosed in its entirety after the formal, public bid opening has been completed.
12. By submission of the proposal, the bidder certifies that the pricing structure offered has been arrived at independently without consultation, communication, or agreement of such prices for the purpose of restricting competition with any other bidder or competitor.
13. The bidder agrees to hold and save Midland Public Schools, its officers, agents, and employees harmless from liability of any kind, including costs and expenses, with respect to any claim, action, cost or judgment for patent, copyright or trademark infringement arising out of the purchase or use of equipment, materials, supplies, or services covered by this bid document.

Bid Form

Trailer/Walk-In Cooler Price	<u>55,900</u>
Delivery Charges	<u>895</u>
Total Pricing	<u>56,795</u>

Please describe any changes to include additions and subtractions from bid specifications

The brand and capacity of the generator can vary depending on availability at the time that this bid may be accepted. If this bid is accepted, we will provide the closest match we can to the requested specs. The generator will have a separate warranty from the trailer and will only be covered by its respective manufacturer

Check to be overnighted after receiving of trailer. A wire transfer is also acceptable.

Delivery should be 30 days or less. That can vary at time of acceptance depending on demand and available inventory. But it shall be

Company Spencer Trailers first available unit.

Title Agent

Phone 812.829.0226

Email bryan@spencertailers.com

My signature certifies that the proposal as submitted complies with all Terms and Conditions as set forth in this RFP.

Signature 

Iran Economic Sanctions Act Certification

I am the Agent (insert title) of Spence Trailers Inc. (insert bidder company name), or I am bidding in my individual capacity ("Bidder"), with authority to submit a binding bid for the equipment sale to Midland Public Schools. I have personal knowledge of the matters described in this Certification, and I am familiar with the Iran Economic Sanctions Act, MCL 129.311, et seq. ("Act"). I am fully aware that the school district will rely on my representations in evaluating bids.

I certify that Bidder is not an Iran-linked business, as that term is defined in the Act. I understand that submission of a false certification may result in contract termination, ineligibility to bid for three (3) years, and a civil penalty of \$250,000 or twice the bid amount, whichever is greater, plus related investigation and legal costs.

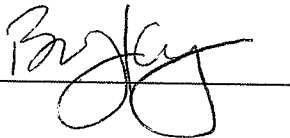
Signature 

Affidavit of Bidder-Compliance with School Safety Initiative Legislation

The undersigned, the owner or authorized officer of Spencer Trailers Inc (the "Bidder"), certifies to Midland Public Schools (the "School District"), that any and all persons who will work directly or indirectly for the Bidder, including, but not limited to, Bidder's employees, agents, vendors, subcontractors or consultants, and who will work at or on any School District property, shall at all times be in compliance with MCL 380.1230, 380.1230a, 380.1230c, 380.1230d, and 380.1230g and have not been convicted of any "listed offenses".¹ The Bidder further warrants and represents that all persons who will work directly or indirectly for the Bidder, including, but not limited to, Bidder's employees, agents, vendors, subcontractors or consultants, and who will work at or on any School District property, shall at all times be in compliance with MCL 380.1230, 380.1230a, 380.1230c, 380.1230d, and 380.1230g. In this regard, Bidder agrees, without limitation, to report within 3 business days to the School District when any such person is charged with a crime listed in Section 1535a(1) of the Revised School Code² or a substantially similar law, and to immediately report to the School District if that person is subsequently convicted, plead guilty or plead no contest to that crime.

BIDDER: Brykey Spencer Trailers Inc

By: Brykey

Its: Agent

Example of Equipment



9. 4. For Action: Concrete Bid (Wamack)

Recommendation

Bids were solicited and a tabulation is provided for concrete repair work within MPS. Areas receiving work include Adams, Central Park, Dow High, Plymouth, Jefferson, and Midland High. Administration recommends issuing a purchase order to Stafford Landscaping of Memphis, MI for \$94,412. Capital Improvement funds will be utilized for this purchase.

Supporting Documents



[_Wobig RFP](#)



[_Three Rivers RFP](#)



[_Stafford Landscaping RFP](#)



[_Pre Bid Meeting Sign In](#)



[_Midland Prevailing Wage](#)



[_Concrete RFP 2026](#)



[_Concrete RFP 2026 Drawings](#)



[_Concrete 2026 Bid Tally](#)



[_Better 2 Enterprises RFP](#)

Bid Form

Adams Elementary
1005 Adams Dr.
Midland, Michigan 48642

Area A \$ 16,999.00

Area B,C,D \$ 5,999.00

Total \$ 22,998.00

Central Park Elementary
1400 Rodd St,
Midland Michigan 48640

Total \$ 4,999.00

Herbert Henry Dow High School
3901 N. Saginaw Rd
Midland, Michigan 48640

Total \$ 30,999.00

Plymouth Elementary
1105 E. Sugnet Rd
Midland, Michigan 48642

Total \$ 11,999.00

Jefferson Middle School
800 W. Chapel Ln
Midland, Michigan 48640

Total \$ 5,999.00

Northeast Middle School
1305 E. Sugnet Rd
Midland Michigan 48642

Total \$ No Bid

Midland High School
1301 Eastlawn Dr.
Midland Michigan 48640

Total \$ 24,999.00

Price Per Cu/Yd Installed \$ 545.00

Please Describe Scope of Work to Include Time Frame of Work

We propose to furnish labor, equipment and material to remove/replace
concrete sidewalks per RFP #36 and drawings dated 03/05/2026. Backfill and
hydroseed disturbed areas when concrete work complete.

Work to be completed by August 10, 2026 per RFP.

Company Wobig Construction Co, Inc

Title President

Phone# 989-752-1294

Email wobigconst@sbcglobal.net

Contact Person Brian Roth

My signature certifies that the proposal as submitted complies with all Terms and Conditions as set forth in this RFP.

Signature 
Brian A Roth, President

Iran Economic Sanctions Act Certification

I am the President (insert title) of Wobig Construction Co, Inc (insert bidder company name), or I am bidding in my individual capacity ("Bidder"), with authority to submit a binding bid for the provision concrete services to Midland Public Schools. I have personal knowledge of the matters described in this Certification, and I am familiar with the Iran Economic Sanctions Act, MCL 129.311, et seq. ("Act"). I am fully aware that the school district will rely on my representations in evaluating bids.

I certify that Bidder is not an Iran-linked business, as that term is defined in the Act. I understand that submission of a false certification may result in contract termination, ineligibility to bid for three (3) years, and a civil penalty of \$250,000 or twice the bid amount, whichever is greater, plus related investigation and legal costs.

Signature Brian A. Roth
Brian A Roth, President

Affidavit of Bidder-Compliance with School Safety Initiative Legislation

The undersigned, the owner or authorized officer of Wobig Construction Co, Inc (the "Bidder"), certifies to Midland Public Schools (the "School District"), that any and all persons who will work directly or indirectly for the Bidder, including, but not limited to, Bidder's employees, agents, vendors, subcontractors or consultants, and who will work at or on any School District property, shall at all times be in compliance with MCL 380.1230, 380.1230a, 380.1230c, 380.1230d, and 380.1230g and have not been convicted of any "listed offenses".¹ The Bidder further warrants and represents that all persons who will work directly or indirectly for the Bidder, including, but not limited to, Bidder's employees, agents, vendors, subcontractors or consultants, and who will work at or on any School District property, shall at all times be in compliance with MCL 380.1230, 380.1230a, 380.1230c, 380.1230d, and 380.1230g. In this regard, Bidder agrees, without limitation, to report within 3 business days to the School District when any such person is charged with a crime listed in Section 1535a(1) of the Revised School Code² or a substantially similar law, and to immediately report to the School District if that person is subsequently convicted, plead guilty or plead no contest to that crime.

BIDDER: Wobig Construction Co, Inc

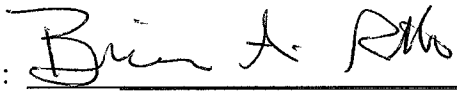
By: 

Its: Brian A Roth, President

Bid Form

Adams Elementary
1005 Adams Dr.
Midland, Michigan 48642

Area A \$ \$24,295

Area B,C,D \$ \$5,278

Total \$ \$29,573

Central Park Elementary
1400 Rodd St,
Midland Michigan 48640

Total \$ \$9,137

Herbert Henry Dow High School
3901 N. Saginaw Rd
Midland, Michigan 48640

Total \$ \$34,450

Plymouth Elementary
1105 E. Sugnet Rd
Midland, Michigan 48642

Total \$ \$9,117

Jefferson Middle School
800 W. Chapel Ln
Midland, Michigan 48640

Total \$ \$8,182

Northeast Middle School
1305 E. Sugnet Rd
Midland Michigan 48642

Total \$ _____

Midland High School
1301 Eastlawn Dr.
Midland Michigan 48640

Total \$ \$36,486

Price Per Cu/Yd Installed \$ 1,075

Please Describe Scope of Work to Include Time Frame of Work

Pour in place sidewalks, and curbs or remove and replace sidewalk and curb
as listed at specified locations

Company Three Rivers Corporation

Title Estimator

Phone# 989-513-2570

Email jwilson@trccompany.com

Contact Person Thom Laney

My signature certifies that the proposal as submitted complies with all Terms and Conditions as set forth in this RFP.

Signature  _____

Affidavit of Bidder-Compliance with School Safety Initiative Legislation

The undersigned, the owner or authorized officer of Three Rivers Corp. (the “Bidder”), certifies to Midland Public Schools (the “School District”), that any and all persons who will work directly or indirectly for the Bidder, including, but not limited to, Bidder’s employees, agents, vendors, subcontractors or consultants, and who will work at or on any School District property, shall at all times be in compliance with MCL 380.1230, 380.1230a, 380.1230c, 380.1230d, and 380.1230g and have not been convicted of any “listed offenses”.¹ The Bidder further warrants and represents that all persons who will work directly or indirectly for the Bidder, including, but not limited to, Bidder’s employees, agents, vendors, subcontractors or consultants, and who will work at or on any School District property, shall at all times be in compliance with MCL 380.1230, 380.1230a, 380.1230c, 380.1230d, and 380.1230g. In this regard, Bidder agrees, without limitation, to report within 3 business days to the School District when any such person is charged with a crime listed in Section 1535a(1) of the Revised School Code² or a substantially similar law, and to immediately report to the School District if that person is subsequently convicted, plead guilty or plead no contest to that crime.

BIDDER: Three Rivers Corporation

By: Jordan Wilson

Its: Estimator

Affidavit of Bidder –Familial Relationships Form

The undersigned, the owner or authorized officer of Three Rivers Corporation (the "Bidder"), pursuant to the familial disclosure requirement provided in the Michigan Public (the "School District") advertisement for construction bids, hereby represent and warrant, except as provided below, that no familial relationships exist between the bidder(s) or any employee of Three Rivers Corporation, and any member of the Board of Education of the School District or the Superintendent of the School District.

List any Familial Relationships:

BIDDER: Three Rivers Corporation

By: [Signature]

Its: Esquire

STATE OF MICHIGAN)
)ss.
COUNTY OF SAGINAW)

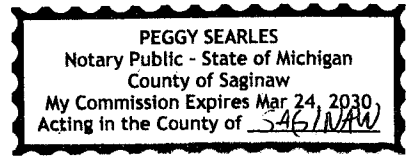

This instrument was acknowledged before me on the 23 day of MARCH, 2026, by PEGGY SEARLES

[Signature]
_____, Notary Public
SAGINAW County, Michigan
My Commission Expires: 3/24/2030
Acting in the County of: SAGINAW

Iran Economic Sanctions Act Certification

Director of commercial

I am the services _____ (insert title) of Three Rivers Corporation (insert bidder company name), or I am bidding in my individual capacity ("Bidder"), with authority to submit a binding bid for the provision concrete services to Midland Public Schools. I have personal knowledge of the matters described in this Certification, and I am familiar with the Iran Economic Sanctions Act, MCL 129.311, et seq. ("Act"). I am fully aware that the school district will rely on my representations in evaluating bids.

I certify that Bidder is not an Iran-linked business, as that term is defined in the Act. I understand that submission of a false certification may result in contract termination, ineligibility to bid for three (3) years, and a civil penalty of \$250,000 or twice the bid amount, whichever is greater, plus related investigation and legal costs.

Signature

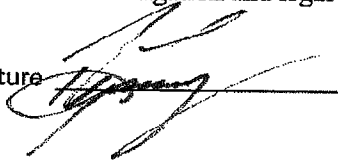
A handwritten signature in black ink, appearing to be a stylized name, written over a horizontal line.

Bid Form

Adams Elementary
1005 Adams Dr.
Midland, Michigan 48642

Area A \$ 20,600.00

Area B,C,D \$ 3,000.00

Total \$ 23,600.00

Central Park Elementary
1400 Rodd St,
Midland Michigan 48640

Total \$ 6,500.00

Herbert Henry Dow High School
3901 N. Saginaw Rd
Midland, Michigan 48640

Total \$ 25,000.00

Plymouth Elementary
1105 E. Sugnet Rd
Midland, Michigan 48642

Total \$ 6,840.00

Jefferson Middle School
800 W. Chapel Ln
Midland, Michigan 48640

Total \$ 3,000.00

Northeast Middle School
1305 E. Sugnet Rd
Midland Michigan 48642

Total \$ N/A

Midland High School
1301 Eastlawn Dr.
Midland Michigan 48640

Total \$ 29,472.00

Price Per Cu/Yd Installed \$ 150.00 @4"

Please Describe Scope of Work to Include Time Frame of Work

Scope of work includes concrete install and removal and replacement in several different areas throughout the school district. All prices represent all materials and labor.
Time frame is flexible, however we would like to start the project after school is dismissed of the summer June 8th for best efficiency.

Company Stafford Landscaping

Title Owner

Phone# 810-310-1281

Email info@staffordlandscaping.net

Contact Person David Stafford

My signature certifies that the proposal as submitted complies with all Terms and Conditions as set forth in this RFP.

Signature _____

Iran Economic Sanctions Act Certification

I am the **Owner** _____ (insert title) of **Stafford Landscaping** _____ (insert bidder company name), or I am bidding in my individual capacity ("Bidder"), with authority to submit a binding bid for the provision concrete services to Midland Public Schools. I have personal knowledge of the matters described in this Certification, and I am familiar with the Iran Economic Sanctions Act, MCL 129.311, et seq. ("Act"). I am fully aware that the school district will rely on my representations in evaluating bids.

I certify that Bidder is not an Iran-linked business, as that term is defined in the Act. I understand that submission of a false certification may result in contract termination, ineligibility to bid for three (3) years, and a civil penalty of \$250,000 or twice the bid amount, whichever is greater, plus related investigation and legal costs.

Signature David Attala

Affidavit of Bidder-Compliance with School Safety Initiative Legislation

The undersigned, the owner or authorized officer of Stafford Landscaping (the “Bidder”), certifies to Midland Public Schools (the “School District”), that any and all persons who will work directly or indirectly for the Bidder, including, but not limited to, Bidder’s employees, agents, vendors, subcontractors or consultants, and who will work at or on any School District property, shall at all times be in compliance with MCL 380.1230, 380.1230a, 380.1230c, 380.1230d, and 380.1230g and have not been convicted of any “listed offenses”.¹ The Bidder further warrants and represents that all persons who will work directly or indirectly for the Bidder, including, but not limited to, Bidder’s employees, agents, vendors, subcontractors or consultants, and who will work at or on any School District property, shall at all times be in compliance with MCL 380.1230, 380.1230a, 380.1230c, 380.1230d, and 380.1230g. In this regard, Bidder agrees, without limitation, to report within 3 business days to the School District when any such person is charged with a crime listed in Section 1535a(1) of the Revised School Code² or a substantially similar law, and to immediately report to the School District if that person is subsequently convicted, plead guilty or plead no contest to that crime.

BIDDER: Stafford Landscaping

By: David Stafford

Its: Owner

Affidavit of Bidder –Familial Relationships Form

The undersigned, the owner or authorized officer of Stafford Landscaping (the "Bidder"), pursuant to the familial disclosure requirement provided in the Midland School District (the "School District") advertisement for construction bids, hereby represent and warrant, except as provided below, that no familial relationships exist between the bidder(s) or any employee of Midland Schools, and any member of the Board of Education of the School District or the Superintendent of the School District.

List any Familial Relationships:

BIDDER: Stafford Landscaping

By: David Stafford

Its: Owner

STATE OF MICHIGAN)
)ss.
COUNTY OF Macomb)

MAEGAN LOHR
NOTARY PUBLIC, STATE OF MI
COUNTY OF MACOMB
MY COMMISSION EXPIRES Mar 22, 2028
ACTING IN COUNTY OF Macomb

This instrument was acknowledged before me on the 23 day of March, 2026, by David Stafford.

Maegan Lohr
_____, Notary Public
Macomb County, Michigan
My Commission Expires: 3/22/28
Acting in the County of: Macomb

Prevailing Wage Rates for State Of Michigan Funded Projects

Official Rate Schedule

Midland

Classification Name	Last Updated		
1.1 Laborer Common	10/28/2025		
Wage Rates	Straight Time	Time and a Half	Double Time
Journeyman	\$41.46	\$55.30	\$69.14
Apprentice: Level 1 0-1000 hours	\$34.54	\$44.92	\$55.30
Apprentice: Level 2 1001-2000 Hours	\$35.92	\$46.99	\$58.06
Apprentice: Level 3 2001-3000 hours	\$36.98	\$48.75	\$60.51
Apprentice: Level 4 3001-4000 hours	\$40.08	\$49.43	\$61.32

Four 10-hour days allowed? - Yes

Make Up Day Allowed? - Yes

Prevailing Wage Rates for State Of Michigan Funded Projects

Official Rate Schedule

Midland

Classification Name	Last Updated		
3.1 Power Equip. Operator - Highway & Heavy	11/01/2025		
Wage Rates	Straight Time	Time and a Half	Double Time
Journeyman	\$71.46	\$94.57	\$117.67
Apprentice: Level 1 0 - 6 Months	\$57.61	\$73.79	\$89.97
Apprentice: Level 2 7 -12 Months	\$59.93	\$77.28	\$94.61
Apprentice: Level 3 13 - 18 Months	\$62.23	\$80.73	\$99.21
Apprentice: Level 4 19 - 24 Months	\$64.54	\$84.19	\$103.83
Apprentice: Level 5 25 - 30 Months	\$66.85	\$87.66	\$108.45
Apprentice: Level 6 31 - 36 Months	\$69.15	\$91.10	\$113.05

Four 10-hour days allowed? - Yes

Make Up Day Allowed? - Yes

Prevailing Wage Rates for State Of Michigan Funded Projects

Official Rate Schedule

Midland

Classification Name	Last Updated		
3.2 Power Equip. Operator - Highway & Heavy	11/01/2025		
Wage Rates	Straight Time	Time and a Half	Double Time
Journeyman	\$70.31	\$92.84	\$115.37
Apprentice: Level 1 0 - 6 Months	\$56.81	\$72.59	\$88.37
Apprentice: Level 2 7 -12 Months	\$59.06	\$75.97	\$92.87
Apprentice: Level 3 13 - 18 Months	\$61.31	\$79.35	\$97.37
Apprentice: Level 4 19 - 24 Months	\$63.56	\$82.72	\$101.87
Apprentice: Level 5 25 - 30 Months	\$65.81	\$86.09	\$106.37
Apprentice: Level 6 31 - 36 Months	\$68.06	\$89.47	\$110.87

Four 10-hour days allowed? - Yes

Make Up Day Allowed? - Yes

Prevailing Wage Rates for State Of Michigan Funded Projects

Official Rate Schedule

Midland

Classification Name	Last Updated		
3.3 Power Equip. Operator - Highway & Heavy	11/01/2025		
Wage Rates	Straight Time	Time and a Half	Double Time
Journeyman	\$63.58	\$82.75	\$101.91
Apprentice: Level 1 0 - 6 Months	\$52.10	\$65.53	\$78.95
Apprentice: Level 2 7 -12 Months	\$54.02	\$68.41	\$82.79
Apprentice: Level 3 13 - 18 Months	\$55.92	\$71.26	\$86.59
Apprentice: Level 4 19 - 24 Months	\$57.84	\$74.14	\$90.43
Apprentice: Level 5 25 - 30 Months	\$59.75	\$77.00	\$94.25
Apprentice: Level 6 31 - 36 Months	\$61.67	\$79.89	\$98.09

Four 10-hour days allowed? - Yes

Make Up Day Allowed? - Yes

Prevailing Wage Rates for State Of Michigan Funded Projects

Official Rate Schedule

Midland

Classification Name	Last Updated		
3.4 Power Equip. Operator - Highway & Heavy	11/01/2025		
Wage Rates	Straight Time	Time and a Half	Double Time
Journeyman	\$63.02	\$81.91	\$100.79
Apprentice: Level 1 0 - 6 Months	\$51.70	\$64.93	\$78.15
Apprentice: Level 2 7 -12 Months	\$53.59	\$67.76	\$81.93
Apprentice: Level 3 13 - 18 Months	\$55.48	\$70.60	\$85.71
Apprentice: Level 4	\$57.36	\$73.42	\$89.47
Apprentice: Level 5 25 - 30 Months	\$59.25	\$76.25	\$93.25
Apprentice: Level 6 31 - 36 Months	\$61.13	\$79.07	\$97.01

Four 10-hour days allowed? - Yes

Make Up Day Allowed? - Yes

Prevailing Wage Rates for State Of Michigan Funded Projects

Official Rate Schedule

Midland

Classification Name	Last Updated		
3.5 Power Equip. Operator - Highway & Heavy	11/01/2025		
Wage Rates	Straight Time	Time and a Half	Double Time
Journeyman	\$44.80	\$60.98	\$77.15
Apprentice: Level 1 0 - 6 Months	\$35.09	\$46.42	\$57.73
Apprentice: Level 2 7 -12 Months	\$36.71	\$48.84	\$60.97
Apprentice: Level 3 13 - 18 Months	\$38.33	\$51.27	\$64.21
Apprentice: Level 4 19 - 24 Months	\$39.95	\$53.71	\$67.45
Apprentice: Level 5 25 - 30 Months	\$41.57	\$56.13	\$70.69
Apprentice: Level 6 31 - 36 Months	\$43.18	\$58.55	\$73.91

Four 10-hour days allowed? - Yes

Make Up Day Allowed? - Yes

Prevailing Wage Rates for State Of Michigan Funded Projects

Official Rate Schedule

Midland

Classification Name	Last Updated		
4.1 Power Equip. Operator - Commercial	10/31/2025		
Wage Rates	Straight Time	Time and a Half	Double Time
Journeyman	\$71.22	\$94.21	\$117.19
Apprentice: Level 1 0 - 6 Months	\$57.43	\$73.52	\$89.61
Apprentice: Level 2 7 - 12 Months	\$59.73	\$76.97	\$94.21
Apprentice: Level 3 13 - 18 Months	\$62.03	\$80.42	\$98.81
Apprentice: Level 4 19 - 24 Months	\$64.32	\$83.86	\$103.39
Apprentice: Level 5 25 - 30 Months	\$66.62	\$87.31	\$107.99
Apprentice: Level 6 31 - 36 Months	\$68.92	\$90.76	\$112.59

Four 10-hour days allowed? - Yes

Make Up Day Allowed? - Yes

Prevailing Wage Rates for State Of Michigan Funded Projects

Official Rate Schedule

Midland

Classification Name	Last Updated		
4.2 Power Equip. Operator - Commercial	10/31/2025		
Wage Rates	Straight Time	Time and a Half	Double Time
Journeyman	\$70.93	\$93.77	\$116.61
Apprentice: Level 1 0 - 6 Months	\$57.22	\$73.21	\$89.19
Apprentice: Level 2 7 - 12 Months	\$59.51	\$76.65	\$93.77
Apprentice: Level 3 13 - 18 Months	\$61.80	\$71.52	\$89.80
Apprentice: Level 4 19 - 24 Months	\$64.07	\$83.48	\$102.89
Apprentice: Level 5 25 - 30 Months	\$66.36	\$86.92	\$107.47
Apprentice: Level 6 31 - 36 Months	\$68.64	\$90.33	\$112.03

Four 10-hour days allowed? - Yes

Make Up Day Allowed? - Yes

Prevailing Wage Rates for State Of Michigan Funded Projects

Official Rate Schedule

Midland

Classification Name	Last Updated		
4.3 Power Equip. Operator - Commercial	11/01/2025		
Wage Rates	Straight Time	Time and a Half	Double Time
Journeyman	\$70.11	\$92.55	\$114.97
Apprentice: Level 1 0 - 6 Months	\$56.66	\$72.37	\$88.07
Apprentice: Level 2 7 - 12 Months	\$58.90	\$75.73	\$92.55
Apprentice: Level 3 13 - 18 Months	\$61.14	\$79.09	\$97.03
Apprentice: Level 4 19 - 24 Months	\$63.38	\$82.45	\$101.51
Apprentice: Level 5 25 -30 Months	\$65.63	\$85.82	\$106.01
Apprentice: Level 6 31 - 36 Months	\$67.87	\$89.18	\$110.49

Four 10-hour days allowed? - Yes

Make Up Day Allowed? - Yes

Prevailing Wage Rates for State Of Michigan Funded Projects

Official Rate Schedule

Midland

Classification Name	Last Updated		
4.4 Power Equip. Operator - Commercial	11/01/2025		
Wage Rates	Straight Time	Time and a Half	Double Time
Journeyman	\$69.25	\$91.25	\$113.25
Apprentice: Level 1 0 - 6 Months	\$56.05	\$71.45	\$86.85
Apprentice: Level 2 7 - 12 Months	\$58.25	\$74.75	\$91.25
Apprentice: Level 3 13 -18 Months	\$60.45	\$78.06	\$95.65
Apprentice: Level 4 19 - 24 Months	\$62.65	\$81.35	\$100.05
Apprentice: Level 5 25 - 30 Months	\$64.85	\$84.66	\$104.45
Apprentice: Level 6 31 -36 Months	\$67.05	\$87.96	\$108.85

Four 10-hour days allowed? - Yes

Make Up Day Allowed? - Yes

Prevailing Wage Rates for State Of Michigan Funded Projects

Official Rate Schedule

Midland

Classification Name	Last Updated		
4.5 Power Equip. Operator - Commercial	11/01/2025		
Wage Rates	Straight Time	Time and a Half	Double Time
Journeyman	\$68.28	\$89.80	\$111.31
Apprentice: Level 1 0 - 6 Months	\$55.37	\$70.44	\$85.49
Apprentice: Level 2 7 -12 Months	\$57.53	\$73.68	\$89.81
Apprentice: Level 3 13 - 18 Months	\$61.83	\$80.12	\$98.41
Apprentice: Level 5 25 - 30 Months	\$63.98	\$83.35	\$102.71
Apprentice: Level 6 31 - 36 Months	\$66.13	\$86.58	\$107.01

Four 10-hour days allowed? - Yes

Make Up Day Allowed? - Yes

Prevailing Wage Rates for State Of Michigan Funded Projects

Official Rate Schedule

Midland

Classification Name	Last Updated		
4.6 Power Equip. Operator - Commercial	11/01/2025		
Wage Rates	Straight Time	Time and a Half	Double Time
Journeyman	\$66.57	\$87.24	\$107.89
Apprentice: Level 1 0 - 6 Months	\$54.17	\$68.64	\$83.09
Apprentice: Level 2 7 -12 Months	\$56.24	\$71.74	\$87.23
Apprentice: Level 3 13 - 18 Months	\$58.30	\$74.82	\$91.35
Apprentice: Level 4 19 -24 Months	\$60.37	\$77.93	\$95.49
Apprentice: Level 5 25 - 30 Months	\$62.44	\$81.04	\$99.63
Apprentice: Level 6 31 - 36 Months	\$64.50	\$84.13	\$103.75

Four 10-hour days allowed? - Yes

Make Up Day Allowed? - Yes

Prevailing Wage Rates for State Of Michigan Funded Projects

Official Rate Schedule

Midland

Classification Name	Last Updated		
4.7 Power Equip. Operator - Commercial	11/01/2025		
Wage Rates	Straight Time	Time and a Half	Double Time
Journeyman	\$59.26	\$67.72	\$84.72
Apprentice: Level	\$54.15	\$68.61	\$83.05
Apprentice: Level 1 0 - 6 Months	\$49.05	\$60.95	\$72.85
Apprentice: Level 2 7 -12 Months	\$50.76	\$63.52	\$76.27
Apprentice: Level 3 13 - 18 Months	\$52.46	\$66.07	\$79.67
Apprentice: Level 5 25 - 30 Months	\$55.85	\$71.16	\$86.45
Apprentice: Level 6 31 - 36 Months	\$57.55	\$73.71	\$89.85

Four 10-hour days allowed? - Yes

Make Up Day Allowed? - Yes

Prevailing Wage Rates for State Of Michigan Funded Projects

Official Rate Schedule

Midland

Classification Name	Last Updated		
4.8 Power Equip. Operator - Commercial	11/01/2025		
Wage Rates	Straight Time	Time and a Half	Double Time
Journeyman	\$58.23	\$74.72	\$91.21
Apprentice: Level 1 0 - 6 Months	\$48.34	\$59.88	\$71.43
Apprentice: Level 2 7 -12 Months	\$49.99	\$62.37	\$74.73
Apprentice: Level 3 13 - 18 Months	\$51.63	\$64.82	\$78.01
Apprentice: Level 4 19 - 24 Months	\$53.29	\$67.31	\$81.33
Apprentice: Level 5 25 - 30 Months	\$54.93	\$69.78	\$84.61
Apprentice: Level 6 25 - 30 Months	\$56.59	\$72.27	\$87.93

Four 10-hour days allowed? - Yes

Make Up Day Allowed? - Yes

Prevailing Wage Rates for State Of Michigan Funded Projects

Official Rate Schedule

Midland

Classification Name	Last Updated		
Articulated Hauler	10/28/2025		
Wage Rates	Straight Time	Time and a Half	Double Time
Journeyman	\$63.02	\$81.91	\$100.79
Apprentice: Apprentice Level 1	\$51.70	\$64.93	\$78.15
Apprentice: Apprentice Level 2	\$53.59	\$67.76	\$81.93
Apprentice: Apprentice Level 3	\$55.48	\$70.60	\$85.71
Apprentice: Apprentice Level 4	\$57.36	\$73.42	\$89.47
Apprentice: Apprentice Level 5	\$59.25	\$76.25	\$93.25
Apprentice: Apprentice Level 6	\$61.13	\$79.07	\$97.01

Four 10-hour days allowed? - No

Make Up Day Allowed? - No

Prevailing Wage Rates for State Of Michigan Funded Projects

Official Rate Schedule

Midland

Classification Name	Last Updated		
Asbestos abatement worker or environmental remediation worker	11/01/2025		
Wage Rates	Straight Time	Time and a Half	Double Time
Journeyman	\$56.20	\$73.24	\$90.28
Apprentice: Trainee 600 hours + 1 year	\$43.12	\$55.01	\$66.90

Four 10-hour days allowed? - Yes

Make Up Day Allowed? - No

Prevailing Wage Rates for State Of Michigan Funded Projects

Official Rate Schedule

Midland

Classification Name	Last Updated		
Boilermaker	10/29/2025		
Wage Rates	Straight Time	Time and a Half	Double Time
Journeyman	\$79.64	\$119.12	\$158.58
Apprentice: 1st Period	\$58.07	\$86.78	\$115.44
Apprentice: 2nd Period	\$59.89	\$89.50	\$119.08
Apprentice: 3rd Period	\$61.81	\$92.24	\$122.74
Apprentice: 4th Period	\$63.50	\$94.91	\$126.30
Apprentice: 5th Period	\$65.26	\$97.54	\$129.82
Apprentice: 6th Period	\$68.89	\$103.00	\$137.08
Apprentice: 7th Period	\$72.46	\$108.36	\$144.22
Apprentice: 8th Period	\$76.07	\$113.77	\$151.44

Four 10-hour days allowed? - Yes

Make Up Day Allowed? - No

Prevailing Wage Rates for State Of Michigan Funded Projects

Official Rate Schedule

Midland

Classification Name	Last Updated		
Boom Truck	10/28/2025		
Wage Rates	Straight Time	Time and a Half	Double Time
Journeyman	\$70.31	\$92.84	\$115.37
Apprentice: Apprentice Level 1	\$56.81	\$72.59	\$88.37
Apprentice: Apprentice Level 2	\$59.06	\$75.97	\$92.87
Apprentice: Apprentice Level 3	\$61.31	\$79.35	\$97.37
Apprentice: Apprentice Level 4	\$63.56	\$82.72	\$101.87

Four 10-hour days allowed? - No

Make Up Day Allowed? - No

Prevailing Wage Rates for State Of Michigan Funded Projects

Official Rate Schedule

Midland

Classification Name	Last Updated		
Bricklayer	10/29/2025		
Wage Rates	Straight Time	Time and a Half	Double Time
Journeyman	\$59.07	\$76.05	\$93.02
Apprentice: Apprentice Level 1	\$40.99	\$51.90	\$62.80
Apprentice: Apprentice Level 2	\$42.83	\$54.66	\$66.48
Apprentice: Apprentice Level 3	\$44.68	\$57.43	\$70.18
Apprentice: Apprentice Level 4	\$46.53	\$60.21	\$73.88
Apprentice: Apprentice Level 5	\$48.37	\$62.97	\$77.56
Apprentice: Apprentice Level 6	\$50.22	\$65.74	\$81.26
Apprentice: Apprentice Level 7 & 8	\$52.07	\$68.52	\$84.96

Four 10-hour days allowed? - No

Make Up Day Allowed? - No

Prevailing Wage Rates for State Of Michigan Funded Projects

Official Rate Schedule

Midland

Classification Name	Last Updated		
Carpenter	11/01/2025		
Wage Rates	Straight Time	Time and a Half	Double Time
Journeyman	\$60.20	\$78.38	\$96.56
Apprentice: Apprentice Level 1	\$49.29	\$62.02	\$74.74
Apprentice: Apprentice Level 2	\$51.11	\$64.75	\$78.38
Apprentice: Apprentice Level 3	\$54.75	\$70.21	\$85.66
Apprentice: Apprentice Level 4	\$58.95	\$76.51	\$94.06

Four 10-hour days allowed? - No

Make Up Day Allowed? - No

Prevailing Wage Rates for State Of Michigan Funded Projects

Official Rate Schedule

Midland

Classification Name	Last Updated		
Carpet layers (linoleum)	11/03/2025		
Wage Rates	Straight Time	Time and a Half	Double Time
Journeyman	\$53.72	\$70.77	\$87.81
Apprentice: Level 1	\$43.49	\$55.42	\$67.35
Apprentice: Level 2	\$45.20	\$57.99	\$70.77
Apprentice: Level 3	\$48.61	\$63.10	\$77.59
Apprentice: Level 4	\$52.02	\$68.22	\$84.41

Four 10-hour days allowed? - Yes

Make Up Day Allowed? - Yes

Prevailing Wage Rates for State Of Michigan Funded Projects

Official Rate Schedule

Midland

Classification Name	Last Updated		
Cement Mason	10/29/2025		
Wage Rates	Straight Time	Time and a Half	Double Time
Journeyman	\$55.78	\$71.69	\$87.60
Apprentice: Apprentice Level 1	\$42.00	\$53.93	\$65.86
Apprentice: Apprentice Level 2	\$43.73	\$56.53	\$69.32
Apprentice: Apprentice Level 3	\$45.51	\$59.20	\$72.88
Apprentice: Apprentice Level 4	\$47.19	\$61.72	\$76.24
Apprentice: Apprentice Level 5 & 6	\$48.93	\$64.33	\$79.72

Four 10-hour days allowed? - No

Make Up Day Allowed? - No

Prevailing Wage Rates for State Of Michigan Funded Projects

Official Rate Schedule

Midland

Classification Name	Last Updated		
Drywall taper	11/01/2025		
Wage Rates	Straight Time	Time and a Half	Double Time
Journeyman	\$52.69	\$67.80	\$82.91
Apprentice: Level 1	\$42.11	\$51.93	\$61.75
Apprentice: Level 2	\$45.13	\$56.46	\$67.79
Apprentice: Level 3	\$49.67	\$63.27	\$76.87

Four 10-hour days allowed? - Yes

Make Up Day Allowed? - Yes

Prevailing Wage Rates for State Of Michigan Funded Projects

Official Rate Schedule

Midland

Classification Name	Last Updated		
Electrician	10/31/2025		
Wage Rates	Straight Time	Time and a Half	Double Time
Journeyman	\$69.95	\$99.93	\$129.90
Apprentice: Apprentice Level 1	\$28.38	\$38.15	\$47.91
Apprentice: Apprentice Level 2	\$33.25	\$45.45	\$57.65
Apprentice: Apprentice Level 3	\$38.13	\$52.78	\$67.41
Apprentice: Apprentice Level 4	\$40.58	\$56.45	\$72.31
Apprentice: Apprentice Level 5	\$45.46	\$63.77	\$82.07
Apprentice: Apprentice Level 6	\$51.56	\$72.92	\$94.27

Four 10-hour days allowed? - No

Make Up Day Allowed? - No

Additional Jurisdiction Detail: Townships of Jasper, Porter, Mount Haley and Ingersol ONLY.

Prevailing Wage Rates for State Of Michigan Funded Projects

Official Rate Schedule

Midland

Classification Name	Last Updated		
Electrician	10/29/2025		
Wage Rates	Straight Time	Time and a Half	Double Time
Journeyman	\$66.52	\$94.69	\$122.86
Apprentice: Apprentice Level 1	\$26.27	\$36.27	\$46.26
Apprentice: Apprentice Level 2	\$28.49	\$39.60	\$50.70
Apprentice: Apprentice Level 3	\$30.71	\$42.93	\$55.14
Apprentice: Apprentice Level 4	\$35.54	\$50.17	\$64.80
Apprentice: Apprentice Level 5	\$37.98	\$53.83	\$69.68
Apprentice: Apprentice Level 6	\$45.29	\$64.80	\$84.30

Four 10-hour days allowed? - No

Make Up Day Allowed? - No

Additional Jurisdiction Detail: All Townships EXCEPT Mount Haley, Jasper, Porter and Ingersoll.

Prevailing Wage Rates for State Of Michigan Funded Projects

Official Rate Schedule

Midland

Classification Name	Last Updated		
Elevator Constructors	11/01/2025		
Wage Rates	Straight Time	Time and a Half	Double Time
Journeyman	\$110.76	\$143.49	\$176.21

Four 10-hour days allowed? - Yes

Make Up Day Allowed? - Yes

Prevailing Wage Rates for State Of Michigan Funded Projects

Official Rate Schedule

Midland

Classification Name	Last Updated		
Glaziers	10/31/2025		
Wage Rates	Straight Time	Time and a Half	Double Time
Journeyman	\$56.55	\$76.37	\$96.20
Apprentice: Level 1	\$40.70	\$52.61	\$64.50
Apprentice: Level 2	\$44.66	\$58.55	\$72.42
Apprentice: Level 3	\$48.63	\$64.50	\$80.36
Apprentice: Level 4	\$52.59	\$70.44	\$88.28

Four 10-hour days allowed? - Yes

Make Up Day Allowed? - Yes

Prevailing Wage Rates for State Of Michigan Funded Projects

Official Rate Schedule

Midland

Classification Name	Last Updated		
Ground Person	11/01/2025		
Wage Rates	Straight Time	Time and a Half	Double Time
Journeyman	\$50.85	\$72.32	\$93.78

Four 10-hour days allowed? - Yes

Make Up Day Allowed? - Yes

Prevailing Wage Rates for State Of Michigan Funded Projects

Official Rate Schedule

Midland

Classification Name	Last Updated		
Heating and frost Insulators	11/03/2025		
Wage Rates	Straight Time	Time and a Half	Double Time
Journeyman	\$52.00	\$68.89	\$85.77
Apprentice: 1st year	\$26.38	\$33.69	\$40.99
Apprentice: 2nd year	\$30.15	\$38.92	\$47.68
Apprentice: 3rd year	\$33.92	\$44.15	\$54.37
Apprentice: 4th year	\$37.70	\$49.39	\$61.08
Apprentice: 5th year	\$41.48	\$54.63	\$67.78

Four 10-hour days allowed? - Yes

Make Up Day Allowed? - Yes

Friday for cancelled work in a 4 10 schedule

Prevailing Wage Rates for State Of Michigan Funded Projects

Official Rate Schedule

Midland

Classification Name	Last Updated		
Ironworker	10/31/2025		
Wage Rates	Straight Time	Time and a Half	Double Time
Journeyman	\$75.42	\$93.70	\$111.97
Apprentice: Apprentice Level 1	\$57.42	\$70.40	\$83.37
Apprentice: Apprentice Level 2	\$59.59	\$73.12	\$86.64
Apprentice: Apprentice Level 3	\$61.54	\$75.43	\$89.32
Apprentice: Apprentice Level 4	\$64.59	\$79.40	\$94.20
Apprentice: Apprentice Level 5	\$67.64	\$83.36	\$99.07
Apprentice: Apprentice Level 6	\$75.42	\$93.70	\$111.97

Four 10-hour days allowed? - No

Make Up Day Allowed? - No

Prevailing Wage Rates for State Of Michigan Funded Projects

Official Rate Schedule

Midland

Classification Name	Last Updated		
Laborer, Common - Highway & Heavy	11/05/2025		
Wage Rates	Straight Time	Time and a Half	Double Time
Journeyman	\$48.27	\$62.46	\$76.64
Apprentice: Level 1	\$41.09	\$51.73	\$62.37
Apprentice: Level 2	\$42.51	\$53.86	\$65.21
Apprentice: Level 3	\$43.92	\$55.98	\$68.03
Apprentice: Level 4	\$46.76	\$60.24	\$73.71

Four 10-hour days allowed? - Yes

Make Up Day Allowed? - Yes

Prevailing Wage Rates for State Of Michigan Funded Projects

Official Rate Schedule

Midland

Classification Name	Last Updated		
Laborer, Landscaping	11/03/2025		
Wage Rates	Straight Time	Time and a Half	Double Time
Journeyman	\$36.87	\$49.23	\$61.58
Apprentice: Apprentice Level 1	\$30.69	\$39.96	\$49.22
Apprentice: Apprentice Level 2	\$31.93	\$41.82	\$51.70
Apprentice: Apprentice Level 3	\$33.16	\$43.66	\$54.16
Apprentice: Apprentice Level 4	\$35.63	\$47.37	\$59.10

Four 10-hour days allowed? - No

Make Up Day Allowed? - No

Prevailing Wage Rates for State Of Michigan Funded Projects

Official Rate Schedule

Midland

Classification Name	Last Updated		
Laborer, Skilled - Commercial	11/04/2025		
Wage Rates	Straight Time	Time and a Half	Double Time
Journeyman	\$42.02	\$56.13	\$70.23

Four 10-hour days allowed? - Yes

Make Up Day Allowed? - Yes

Prevailing Wage Rates for State Of Michigan Funded Projects

Official Rate Schedule

Midland

Classification Name	Last Updated		
Laborer, Skilled - Highway & Heavy	11/05/2025		
Wage Rates	Straight Time	Time and a Half	Double Time
Journeyman	\$49.27	\$63.96	\$78.64
Apprentice: Apprentice Level 1	\$41.84	\$52.86	\$63.87
Apprentice: Apprentice Level 2	\$43.31	\$55.06	\$66.81
Apprentice: Apprentice Level 3	\$44.68	\$57.16	\$69.64
Apprentice: Apprentice Level 4	\$47.71	\$61.66	\$75.61

Four 10-hour days allowed? - No

Make Up Day Allowed? - No

Prevailing Wage Rates for State Of Michigan Funded Projects

Official Rate Schedule

Midland

Classification Name	Last Updated		
Landscaping equipment	10/28/2025		
Wage Rates	Straight Time	Time and a Half	Double Time
Journeyman	\$39.09	\$52.56	\$66.02

Four 10-hour days allowed? - No

Make Up Day Allowed? - No

Prevailing Wage Rates for State Of Michigan Funded Projects

Official Rate Schedule

Midland

Classification Name	Last Updated		
Lineman	10/30/2025		
Wage Rates	Straight Time	Time and a Half	Double Time
Journeyman	\$76.81	\$111.26	\$145.70
Apprentice: Level 1 0-1000 hours	\$49.26	\$69.94	\$90.60
Apprentice: Level 2 1001-2000 Hours	\$52.71	\$75.11	\$97.50
Apprentice: Level 3 2001-3000 Hours	\$56.15	\$80.28	\$104.38
Apprentice: Level 4 3001-4000 hours	\$59.60	\$85.44	\$111.28
Apprentice: Level 5 4001-5000 Hours	\$63.04	\$90.60	\$118.16
Apprentice: Level 6 5001-6000 Hours	\$66.48	\$95.77	\$125.04
Apprentice: Level 7	\$69.93	\$100.94	\$131.94

Four 10-hour days allowed? - Yes

Make Up Day Allowed? - Yes

Prevailing Wage Rates for State Of Michigan Funded Projects

Official Rate Schedule

Midland

Classification Name	Last Updated		
Millwright	11/05/2025		
Wage Rates	Straight Time	Time and a Half	Double Time
Journeyman	\$82.65	\$126.09	\$165.30
Apprentice: Level 1	\$60.79	\$91.21	\$121.58
Apprentice: Level 2	\$68.09	\$102.15	\$136.18
Apprentice: Level 3	\$75.36	\$113.05	\$150.72
Apprentice: Level 4	\$79.01	\$118.54	\$158.02

Four 10-hour days allowed? - Yes

Make Up Day Allowed? - Yes

Prevailing Wage Rates for State Of Michigan Funded Projects

Official Rate Schedule

Midland

Classification Name	Last Updated		
Off-Road Truck	10/29/2025		
Wage Rates	Straight Time	Time and a Half	Double Time
Journeyman	\$63.02	\$81.91	\$100.79
Apprentice: Apprentice Level 1	\$51.70	\$64.93	\$78.15
Apprentice: Apprentice Level 2	\$53.59	\$67.76	\$81.93
Apprentice: Apprentice Level 3	\$55.48	\$70.60	\$85.71
Apprentice: Apprentice Level 4	\$57.36	\$73.42	\$89.47
Apprentice: Apprentice Level 5	\$59.25	\$76.25	\$93.25
Apprentice: Apprentice Level 6	\$61.13	\$79.07	\$97.01

Four 10-hour days allowed? - No

Make Up Day Allowed? - No

Prevailing Wage Rates for State Of Michigan Funded Projects

Official Rate Schedule

Midland

Classification Name	Last Updated		
Painters	10/30/2025		
Wage Rates	Straight Time	Time and a Half	Double Time
Journeyman	\$48.48	\$63.10	\$77.71
Apprentice: Apprentice Level 1	\$36.79	\$45.56	\$54.33
Apprentice: Apprentice Level 2	\$39.71	\$49.94	\$60.17
Apprentice: Apprentice Level 3	\$42.63	\$54.32	\$66.01
Apprentice: Apprentice Level 4	\$45.56	\$58.72	\$71.87

Four 10-hour days allowed? - No

Make Up Day Allowed? - No

Prevailing Wage Rates for State Of Michigan Funded Projects

Official Rate Schedule

Midland

Classification Name	Last Updated		
Piledriver	11/01/2025		
Wage Rates	Straight Time	Time and a Half	Double Time
Journeyman	\$60.20	\$78.38	\$96.56
Apprentice: Apprentice Level 1	\$49.29	\$62.02	\$74.74
Apprentice: Apprentice Level 2	\$51.11	\$64.75	\$78.38
Apprentice: Apprentice Level 3	\$54.75	\$70.21	\$85.66
Apprentice: Apprentice Level 4	\$58.95	\$76.51	\$94.06

Four 10-hour days allowed? - No

Make Up Day Allowed? - No

Prevailing Wage Rates for State Of Michigan Funded Projects

Official Rate Schedule

Midland

Classification Name	Last Updated		
Pipefitters—Steamfitters	11/01/2025		
Wage Rates	Straight Time	Time and a Half	Double Time
Journeyman	\$63.84	\$84.35	\$104.85
Apprentice: Level 1	\$38.67	\$48.92	\$59.17
Apprentice: Level 2	\$41.30	\$52.58	\$63.86
Apprentice: Level 3	\$43.90	\$56.21	\$68.51
Apprentice: Level 4	\$46.50	\$59.83	\$73.16
Apprentice: Level 5	\$49.10	\$63.46	\$77.81
Apprentice: Level 6	\$51.70	\$67.08	\$82.46
Apprentice: Level 7	\$54.30	\$70.71	\$87.11
Apprentice: Level 8	\$56.90	\$74.33	\$91.76
Apprentice: Level 9	\$59.50	\$77.95	\$96.41

Four 10-hour days allowed? - Yes

Make Up Day Allowed? - Yes

Prevailing Wage Rates for State Of Michigan Funded Projects

Official Rate Schedule

Midland

Classification Name	Last Updated		
Plasterer	10/29/2025		
Wage Rates	Straight Time	Time and a Half	Double Time
Journeyman	\$57.16	\$72.50	\$87.84
Apprentice: Apprentice Level 1	\$43.02	\$54.40	\$65.78
Apprentice: Apprentice Level 2	\$44.75	\$56.99	\$69.24
Apprentice: Apprentice Level 3	\$46.48	\$59.59	\$72.70
Apprentice: Apprentice Level 4	\$48.20	\$62.17	\$76.14
Apprentice: Apprentice Level 5 & 6	\$49.93	\$64.77	\$79.60

Four 10-hour days allowed? - No

Make Up Day Allowed? - No

Prevailing Wage Rates for State Of Michigan Funded Projects

Official Rate Schedule

Midland

Classification Name	Last Updated		
Plumbers	10/29/2025		
Wage Rates	Straight Time	Time and a Half	Double Time
Journeyman	\$69.18	\$92.18	\$115.18
Apprentice: Level 1	\$41.55	\$53.05	\$64.55
Apprentice: Level 2	\$44.39	\$57.04	\$69.69
Apprentice: Level 3	\$47.24	\$61.04	\$74.84
Apprentice: Level 4	\$50.09	\$65.04	\$79.99
Apprentice: Level 5	\$52.94	\$69.04	\$85.14
Apprentice: Level 6	\$55.79	\$73.04	\$90.29
Apprentice: Level 7	\$58.64	\$77.04	\$95.44
Apprentice: Level 8	\$61.49	\$81.04	\$100.59
Apprentice: Level 9	\$64.34	\$85.04	\$105.74

Four 10-hour days allowed? - Yes

Make Up Day Allowed? - Yes

Prevailing Wage Rates for State Of Michigan Funded Projects

Official Rate Schedule

Midland

Classification Name	Last Updated		
Roofer/Waterproofer	11/03/2025		
Wage Rates	Straight Time	Time and a Half	Double Time
Journeyman	\$49.76	\$63.95	\$78.14
Apprentice: Apprentice 1	\$35.27	\$42.22	\$49.16
Apprentice: Apprentice 2	\$36.91	\$44.68	\$52.44
Apprentice: Apprentice 3	\$36.31	\$43.78	\$51.24
Apprentice: Apprentice 4	\$37.93	\$46.20	\$54.48
Apprentice: Apprentice 5	\$34.45	\$40.98	\$47.52
Apprentice: Apprentice 6	\$41.18	\$51.08	\$60.98
Apprentice: Apprentice 7	\$42.51	\$53.08	\$63.64
Apprentice: Apprentice 8	\$44.42	\$55.94	\$67.46

Four 10-hour days allowed? - Yes

Make Up Day Allowed? - Yes

Prevailing Wage Rates for State Of Michigan Funded Projects

Official Rate Schedule

Midland

Classification Name	Last Updated		
Sheet Metal Workers	10/31/2025		
Wage Rates	Straight Time	Time and a Half	Double Time
Journeyman	\$67.48	\$86.53	\$105.58
Apprentice: 1st Year Apprentice	\$36.88	\$48.31	\$59.74
Apprentice: 2nd Year Apprentice	\$38.98	\$51.37	\$63.75
Apprentice: 3rd Year Apprentice	\$45.95	\$59.29	\$72.62
Apprentice: 4th Year Apprentice	\$50.14	\$65.38	\$80.62

Four 10-hour days allowed? - No

Make Up Day Allowed? - No

Prevailing Wage Rates for State Of Michigan Funded Projects

Official Rate Schedule

Midland

Classification Name	Last Updated		
Sprinkler Fitters	11/03/2025		
Wage Rates	Straight Time	Time and a Half	Double Time
Journeyman	\$60.34	\$78.45	\$96.56
Apprentice: Class 1	\$24.57	\$32.72	\$40.87
Apprentice: Class 10	\$52.07	\$68.37	\$84.67
Apprentice: Class 2	\$26.38	\$35.43	\$44.49
Apprentice: Class 3	\$39.14	\$49.10	\$59.06
Apprentice: Class 4	\$40.95	\$51.82	\$62.68
Apprentice: Class 5	\$43.01	\$54.78	\$66.55
Apprentice: Class 6	\$44.82	\$57.49	\$70.17
Apprentice: Class 7	\$46.63	\$60.21	\$73.79
Apprentice: Class 8	\$48.45	\$62.94	\$77.43
Apprentice: Class 9	\$50.26	\$65.65	\$81.05

Four 10-hour days allowed? - Yes

Make Up Day Allowed? - Yes

Prevailing Wage Rates for State Of Michigan Funded Projects

Official Rate Schedule

Midland

Classification Name	Last Updated		
Terrazzo Worker	10/29/2025		
Wage Rates	Straight Time	Time and a Half	Double Time
Journeyman	\$53.82	\$68.77	\$83.72
Apprentice: Apprentice Level 1	\$40.55	\$49.87	\$59.18
Apprentice: Apprentice Level 2	\$42.29	\$52.48	\$62.66
Apprentice: Apprentice Level 3	\$44.02	\$55.07	\$66.12
Apprentice: Apprentice Level 4	\$45.76	\$57.68	\$69.60
Apprentice: Apprentice Level 5	\$47.49	\$60.28	\$73.06
Apprentice: Apprentice Level 6	\$49.23	\$62.89	\$76.54
Apprentice: Apprentice Level 7 & 8	\$50.95	\$64.75	\$79.02

Four 10-hour days allowed? - No

Make Up Day Allowed? - No

Prevailing Wage Rates for State Of Michigan Funded Projects

Official Rate Schedule

Midland

Classification Name	Last Updated		
Tile Finisher	10/29/2025		
Wage Rates	Straight Time	Time and a Half	Double Time
Journeyman	\$49.30	\$62.80	\$76.30
Apprentice: Apprentice Level 1	\$40.67	\$50.86	\$61.04
Apprentice: Apprentice Level 2	\$42.20	\$53.15	\$64.10
Apprentice: Apprentice Level 3	\$44.60	\$55.94	\$67.28
Apprentice: Apprentice Level 4	\$43.72	\$55.43	\$67.14
Apprentice: Apprentice Level 5 & 6	\$46.77	\$46.77	\$46.77

Four 10-hour days allowed? - No

Make Up Day Allowed? - No

Prevailing Wage Rates for State Of Michigan Funded Projects

Official Rate Schedule

Midland

Classification Name	Last Updated		
Tile Setter			
10/29/2025			
Wage Rates	Straight Time	Time and a Half	Double Time
Journeyman	\$53.32	\$68.02	\$82.72
Apprentice: Apprentice Level 1	\$40.24	\$49.40	\$58.56
Apprentice: Apprentice Level 2	\$41.95	\$51.97	\$61.98
Apprentice: Apprentice Level 3	\$43.65	\$54.52	\$65.38
Apprentice: Apprentice Level 4	\$45.36	\$57.08	\$68.80
Apprentice: Apprentice Level 5	\$47.06	\$59.63	\$72.20
Apprentice: Apprentice Level 6	\$48.77	\$62.20	\$75.62
Apprentice: Apprentice Level 7 & 8	\$50.47	\$64.75	\$79.02

Four 10-hour days allowed? - No

Make Up Day Allowed? - No

Prevailing Wage Rates for State Of Michigan Funded Projects

Official Rate Schedule

Midland

Classification Name	Last Updated		
Tunnel Miner	11/03/2025		
Wage Rates	Straight Time	Time and a Half	Double Time
Journeyman	\$52.82	\$70.02	\$87.22
Apprentice: Level 1	\$44.22	\$57.12	\$70.02
Apprentice: Level 2	\$45.94	\$59.70	\$73.46
Apprentice: Level 3	\$47.66	\$62.28	\$76.90
Apprentice: Level 4	\$51.10	\$61.35	\$75.66

Four 10-hour days allowed? - Yes

Make Up Day Allowed? - Yes

REQUEST FOR PROPOSAL

CONCRETE INSTALLATION AND REPLACEMENT DISTRICT WIDE 2026

SCOPE:

Unless otherwise specified herein or shown on the Plans, all materials, procedures, and workmanship shall conform to the requirements of the MDOT 2013 Standard Specifications for construction.

Contractors Qualifications

Contractor must have five years of experience in this type or similar work.

Construction Methods:

- The sub-grade shall be formed by trenching or filling to the required elevation for bottom of concrete or to the bottom of the sub-base, if a sub-base is specified. The sub-grade shall be thoroughly tamped or otherwise compacted. A minimum of four inches of Class A sand is required, and if not present, be placed as sub-base.
- Before concrete is placed, the sub-grade shall be thoroughly wetted so that the sub-grade is uniformly moist, without forming wet or muddy spots.
- Sub-base consisting of sand or sand gravel, shall be placed under the structure, to a 4 inch depth.
- The forms shall be of wood or metal, straight and free from distortion, and of sufficient strength to resist springing during the process of depositing and finishing the concrete. The forms shall be the full depth of the concrete. They shall be set firmly on the sub-grade, true to the required line and grade, and be held in place by adequate stakes, and shall be thoroughly clean and free from foreign material. Approved flexible steel or wood forms may be used for sharp curves or special sections.

- Minimum thickness of the concrete is indicated on the drawings provided for each area to be replaced.
- The concrete shall be thoroughly spaded along the forms and joints before finishing operations are started. The concrete shall be alternately tamped and struck off with a proper strike board until all voids are removed and the surface has the required grade and cross section. The surface shall be floated with a steel float just enough to produce a smooth surface free from irregularities.
- All edges on all sidewalks shall be rounded to a radius of $\frac{1}{4}$ inch with an approved finishing tool. All joints shall be rounded with an approved double edging tool and have a radius of $\frac{1}{4}$ inch on each side. The surface shall be brushed lightly to produce a slightly roughened surface and remove the finishing tool marks. Curing of concrete shall be performed by use of one of the appropriate methods as specified for concrete curing agents in the MDOT Standard Specification for Construction dated 2013 in section 903.
- Backfilling shall be performed after the concrete has set sufficiently and the side forms have been removed. The space on both sides of the walk shall be backfilled with sound earth which shall be compacted and trimmed.
- Care shall be taken so as to not cause damage to Midland Public Schools property and any adjoining property with equipment or materials. Contractor is responsible for any damage to District or other property caused by their neglect.
- Clean-up shall be completed before final acceptance of the work. The Contractor shall clean the street surface, walk, gutters, fences, lawns, private property, right of way, and structures, leaving them in as good a condition as originally found, and shall remove all machinery, tools, surplus materials, temporary buildings and other temporary structures from the site.

Concrete Sawing: This Work shall consist of sawing a neat joint with the Contractor. Application may occur primarily at locations where the existing sidewalk joint is not broken. Depth of cut shall be sufficient to ensure a clean breaking joint.

Joints: Shall be constructed to provide for expansion and contraction of the concrete as follows:

- Joints shall be constructed true to line, with their faces perpendicular to the surface of

the concrete. Transverse joints shall be constructed at right angles to the centerline of a sidewalk, and longitudinal joints shall be constructed parallel to centerline, unless otherwise required. When a sidewalk is constructed in partial width slabs, transverse joints in the succeeding slab shall be placed in line with like joints in the adjacent slab. In the case of widening an existing sidewalk, transverse joints shall be placed in line with the like joints in the existing sidewalk. All standard linear sidewalks shall have transverse joints located at five foot intervals.

- Expansion joints, ½ inch thick, extending to the full depth of the concrete, shall be placed between the concrete and the back of the abutting curb or gutter at intersections and at those locations where the concrete extends from a building or other rigid structure to the curb, and at intervals of no greater than fifty (50) feet. Expansion joint material shall be extended to the full depth of the joint and the top shall be slightly below the finished surface.
- Contraction joints shall be constructed by dividing the sidewalk into areas of approximately twenty-five square feet unless otherwise shown on the Plans. Insofar as feasible, the unit areas shall be square of not less than nine square feet.

Curb Installation: Contractor shall follow curb details found on page eight (P-8) on the drawings included in this RFP.

Protection of concrete: Protection of concrete shall be performed in the following manner:

- The Contractor shall be responsible for the proper protection of the sidewalk until sufficiently hard.
- Protection against rain – The Contractor shall take such precautions as are necessary to protect the concrete from damage.
- Hot weather limitations – Casting of concrete during hot weather shall be limited by the temperature of the concrete at the time of placing. Concrete shall not be cast when the temperature of the concrete is above 90F.

Remove and Dispose of Existing Concrete Sidewalk: Removal areas of sidewalk shall be indicated on the attached drawing with approximate measurements. Contractors are responsible for confirming measurements. This work shall consist of removing sidewalk to the nearest broken or sawed joint. Disturbance of the adjacent piece not to be removed will not be allowed. If an adjacent piece is disturbed, Contractor shall remove and replace at Contractor's expense. Once

the concrete is removed, Contractor shall be held responsible for protecting that area of the work with necessary and appropriate barricades.

Restoration: All areas disturbed during the crosswalk reconstruction or sidewalk repair shall be Restored at the contractors expense with topsoil, seed and mulch.

Notes:

The square footages are approximates and all contractors shall make their own field measurements prior to bidding. Your bid shall be based on your actual field measurements prior to bidding. Your bid shall be based on the actual field measurements and not on the approximate amounts of the square footages involved. No extras will be allowed because of the difference between the districts supplied square footages and the actual field measurements of the contractors.

Site Visit

Contractors may walk the site to determine the scope of work, equipment and materials required, and square footage by setting up an appointment with Michael Moeggenberg before the bid opening:

Michael Moeggenberg
Director of Facilities and Operations
Midland Public Schools
989-923-5035
moeggenbergmj@midlandps.org

Pre-Bid Meeting

There will be a mandatory pre-bid meeting on March 12, 2026, 1:00 P.M at the Midland Public Schools Maintenance Shop (811 George St, Midland Michigan 48640). Please enter through the Transportation Public Entrance indicated above the door.

Bid Information

Bids will be accepted until 2:00 P.M. local time on March 23, 2026, at which time bids will be opened and read aloud for presentation to the Board of Education at their next regularly scheduled meeting. No oral, telephonic, or facsimile proposals will be considered. NO proposals will be considered after the time of closing of bids.

Performance Bond

A Performance Bond by a qualified surety authorized to do business in Michigan in the amount of twenty-five percent (25%) of the Base Bid shall be provided by the successful contractor for each proposal or proposal combination.

Payment Bond

A Payment bond of twenty-five percent (25%) of the Base Bid shall be provided by the successful contractor for each proposal or proposal combination.

Prevailing Wage Requirements

In order to bid on this RFP a contractor must hold a state project registration and any sub-contractor working on this job must also hold a state project registration. The successful contractor is required by law to pay prevailing wage for this job. All documents pertaining to prevailing wage must be processed and the successful contractor must submit pay records for each pay period to the district and to the Michigan Department of Labor and Economic Opportunity. Documentation on prevailing wage for this RFP are included as an attachment. All other prevailing wage laws in the State of Michigan must be adhered to for this contract.

Payment:

The successful bidder will be required to submit a pay application to receive payment. The district will have up to thirty (30) days to submit payment to the contractor for the work completed and materials on site.

Safety

The Contractor shall be responsible for compliance with all applicable federal and state laws, codes, and regulations, including but not limited to MIOSHA and the Right-to-Know.

Fines for MIOSHA Violations

If the District is assessed any fines for MIOSHA violations arising out of these contract services and attributable to the Contractor, the Contractor shall reimburse the District for these.

Permits

The contractor is required to obtain and pay for any required permits both state and local.

Insurance Requirements

The Contractor will provide the District with the required insurance certificates before the Contractor is awarded the contract. These certificates of insurance shall be submitted to the District's Facilities Department. Once contract is awarded Midland Public Schools will need to be added as an additional insured to the insurance policies.

Minimum Required Insurance Limits

	Minimum Limits
Commercial General Liability	
Fire Damage	\$100,000
Medical Expenses	\$ 10,000
Personal & Adv. Injury	
Each Occurrence	\$1,000,000
Aggregate \$2,000,000	
Products - Comp/Op Agg.	\$1,000,000
Property Damage	
Each Occurrence	\$1,000,000
Aggregate	\$2,000,000
Excess Liability (Umbrella)	
Each Occurrence	\$5,000,000
Aggregate	\$10,000,000
Fidelity/Employee Dishonesty Bond	\$50,000
Automobile Liability (Including Hired & Non-Owned)	
Personal Injury/Bodily Injury	
Each Occurrence	\$1,000,000
Or Combined Single Limit	\$1,000,000
Property Damage	
Each Occurrence	\$500,000

The Contractor must also provide all of its employees working on this contract with Workers' Compensation insurance. The District will not be responsible for any job related injuries to the

Contractor's employees. Contractor will provide the District with proof of insurance with at least the following coverage limits:

Minimum Limits

Coverage A Statutory

Coverage B as follows:

Each Accident \$500,000

Disease - Policy Limit \$1,000,000

Disease - Each Employee \$500,000

Owners Rights

The Board of Education reserves the right to accept or reject any or all item(s) in the bid; to accept or reject any or all bid(s); to waive any informalities therein; or for any reason, to award the contract to other than the low bidder. If a unit price or extended price is obviously in error and the other is obviously correct, the incorrect price will be disregarded. The district reserves the right to award the bid by location, to the low bidder of that location and to not award a location to any bidder.

All bids shall be firm for one hundred eighty days (180) from the date of the bid opening. The successful bidder must include a signed "Iran Economic Sanctions Act Certification" and a "Familial Relationship Disclosure" form (enclosed with documents).

All bids must be submitted on the attached bid form and signed by the bidder. Two (2) copies of the bid form should be addressed to the attention of:

Michael Moeggenberg
Director of Facilities and
Operations
Midland Public Schools
600 East Carpenter Street
Midland, Michigan 48640
"Concrete Work 2026"

One (1) copy of the bid form should be retained for your files. Questions should be referred to Michael Moeggenberg, Director of Facilities and Operations at 989-923-5035 or moeggenbergmj@midlandps.org

Work Timeline

The work as soon as a purchase order is issued and shall be completed by August 10, 2026. The district will work with the successful contractor on areas that can be worked on while school is in session. Areas that are not available will need to be worked on during breaks or after June 8, 2026.

Instruction to Bidders

1. It shall be the bidder's responsibility to read this entire document, review all enclosures and attachment, and comply with all requirements specified within.
2. Bids received after the scheduled opening time will not be accepted.
3. The only bids accepted will be hard copy paper bids.
4. No bid may be withdrawn, changed or modified in any way for a period of one hundred eighty (180) calendar days from date of did opening.
5. Negligence on the part of the bidder in preparing the bid confers no rights for the withdrawal of the bid after it has been opened.
6. Bids received prior to time of opening will be kept securely unopened. No responsibility will be attached to school district employee who prematurely opens an incorrectly addressed bid proposal.
7. If either a unit price or extended price is obviously in error or the other is obviously correct, the incorrect price will be disregarded.
8. Midland Public Schools is exempt from state and federal taxes.
9. All bids are subject to acceptance by Midland Public Schools Board of Education which reserves the right to accept or reject any or all bids, to split awards by items, to waive irregularities or defects, and accept other than the low bid when deemed to be in the best interest of Midland Public Schools.
10. The laws of the State of Michigan shall govern rights, obligations, and remedies of the Parties under this bid and any agreement reached through this process.
11. All information included in a bid response is subject to the Freedom of Information Act and may be disclosed in its entirety after the formal, public bid opening has been completed.
12. By submission of the proposal, the bidder certifies that the pricing structure offered has been arrived at independently without consultation, communication, or agreement of such prices for the purpose of restricting competition with any other bidder or competitor.
13. The bidder agrees to hold and save Midland Public Schools, its officers, agents and employees harmless from liability of any kind, including costs and expenses, with respect to any claim, actin, cost or judgment for patent, copyright or trademark infringement arising out of the purchase or use of equipment, materials, supplies, or services covered by this bid document.

14. The contractor shall provide items of a minor nature, not specifically noted in these specifications, so as to provide a complete, operable and Owner acceptable service.
15. Contractors are required to comply with the Safety Rules and Accident Prevention plan. The district reserves the right to exclude any worker(s) from the job site(s) for violation of these work rules or any other such offenses deemed inappropriate by the District.
16. The contractor shall clean their job area daily and dispose of all trash and debris leaving the area broom clean.
17. It is the responsibility of the contractor/bidder to field verify all existing field conditions. Bidders shall inspect the work site and take such steps as may be reasonably necessary to ascertain the nature of the work; and general and local conditions which can affect the work or cost thereof. Failure to do so will not relieve the bidders from responsibility for estimating properly the difficulty or cost of successfully performing the work.
18. The sites are available for your inspections by appointment.

Bid Form

Adams Elementary
1005 Adams Dr.
Midland, Michigan 48642

Area A \$ _____

Area B,C,D \$ _____

Total \$ _____

Central Park Elementary
1400 Rodd St,
Midland Michigan 48640

Total \$ _____

Herbert Henry Dow High School
3901 N. Saginaw Rd
Midland, Michigan 48640

Total \$ _____

Plymouth Elementary
1105 E. Sugnet Rd
Midland, Michigan 48642

Total \$ _____

Jefferson Middle School
800 W. Chapel Ln
Midland, Michigan 48640

Total \$ _____

Northeast Middle School
1305 E. Sugnet Rd
Midland Michigan 48642

Total \$ _____

Midland High School
1301 Eastlawn Dr.
Midland Michigan 48640

Total \$ _____

Price Per Cu/Yd Installed \$ _____

Please Describe Scope of Work to Include Time Frame of Work

Company _____

Title _____

Phone# _____

Email _____

Contact Person _____

My signature certifies that the proposal as submitted complies with all Terms and Conditions as set forth in this RFP.

Signature _____

Iran Economic Sanctions Act Certification

I am the _____ (insert title) of _____ (insert bidder company name), or I am bidding in my individual capacity ("Bidder"), with authority to submit a binding bid for the provision concrete services to Midland Public Schools. I have personal knowledge of the matters described in this Certification, and I am familiar with the Iran Economic Sanctions Act, MCL 129.311, et seq. ("Act"). I am fully aware that the school district will rely on my representations in evaluating bids.

I certify that Bidder is not an Iran-linked business, as that term is defined in the Act. I understand that submission of a false certification may result in contract termination, ineligibility to bid for three (3) years, and a civil penalty of \$250,000 or twice the bid amount, whichever is greater, plus related investigation and legal costs.

Signature _____

Affidavit of Bidder-Compliance with School Safety Initiative Legislation

The undersigned, the owner or authorized officer of _____ (the “Bidder”), certifies to Midland Public Schools (the “School District”), that any and all persons who will work directly or indirectly for the Bidder, including, but not limited to, Bidder’s employees, agents, vendors, subcontractors or consultants, and who will work at or on any School District property, shall at all times be in compliance with MCL 380.1230, 380.1230a, 380.1230c, 380.1230d, and 380.1230g and have not been convicted of any “listed offenses”.¹ The Bidder further warrants and represents that all persons who will work directly or indirectly for the Bidder, including, but not limited to, Bidder’s employees, agents, vendors, subcontractors or consultants, and who will work at or on any School District property, shall at all times be in compliance with MCL 380.1230, 380.1230a, 380.1230c, 380.1230d, and 380.1230g. In this regard, Bidder agrees, without limitation, to report within 3 business days to the School District when any such person is charged with a crime listed in Section 1535a(1) of the Revised School Code² or a substantially similar law, and to immediately report to the School District if that person is subsequently convicted, plead guilty or plead no contest to that crime.

BIDDER: _____

By: _____

Its: _____

Affidavit of Bidder –Familial Relationships Form

The undersigned, the owner or authorized officer of _____ (the “Bidder”), pursuant to the familial disclosure requirement provided in the _____ (the “School District”) advertisement for construction bids, hereby represent and warrant, except as provided below, that no familial relationships exist between the bidder(s) or any employee of _____, and any member of the Board of Education of the School District or the Superintendent of the School District.

List any Familial Relationships:

BIDDER: _____

By: _____

Its: _____

STATE OF MICHIGAN)
)ss.
COUNTY OF _____)

This instrument was acknowledged before me on the ____ day of _____, 2026, by _____.

_____, Notary Public
_____, County, Michigan
My Commission Expires: _____
Acting in the County of : _____

PROPERTY LINE

THREE AREAS OF CONCRETE REPLACEMENT AND ONE ADDITION AS FOLLOWS:

- (A) ADD A 2060 SQ/FT CONCRETE PAD AT A DEPTH OF 4"
- (B) REPLACE 25'L X 6'W X 4"D SECTION OF SIDEWALK
- (C) REPLACE 10'L X 5'6"W X 4"D SECTION OF SIDEWALK AND A 2' SECTION OF CURB
- (D) REPLACE 10'L X 5'6"W X 4"D SECTION OF SIDEWALK

NOTES:

1. WORK TO INCLUDE SAW CUTTING WHERE NECESSARY TO REMOVE SMALLER SECTIONS THAT ARE WITHIN LARGER AREAS.
2. ALL CONCRETE AND SPOIL TO BE REMOVED FROM SITE.
3. WHERE NECESSARY PERFORM EXCAVATION OF SOIL AS REQUIRED TO ATTAIN PROPER DEPTH FOR CONCRETE THICKNESS.
4. PROVIDE CLEAN SANDFILL WHERE NECESSARY, INCLUDING COMPACTION, TO ATTAIN SUITABLE BASE.
5. ALL NEW CONCRETE SLABS TO INCLUDE EXPANSION JOINT MATERIAL AT EXISTING JOINTS THAT ARE BEING REPLACED WITH NEW. PROVIDE "SCORED" CONTROL JOINTS AT SPACING TO MATCH EXISTING SLAB
6. CONTRACTOR TO INSTALL GRADED BACKFILL IN AREAS WHERE FORM WORK OR OTHER RELATED WORK CAUSES DEPRESSIONS, AND SEED.
7. ALL NEW CONCRETE TO BE 4000 PSI WITH MESH OR FIBER

PROPERTY LINE

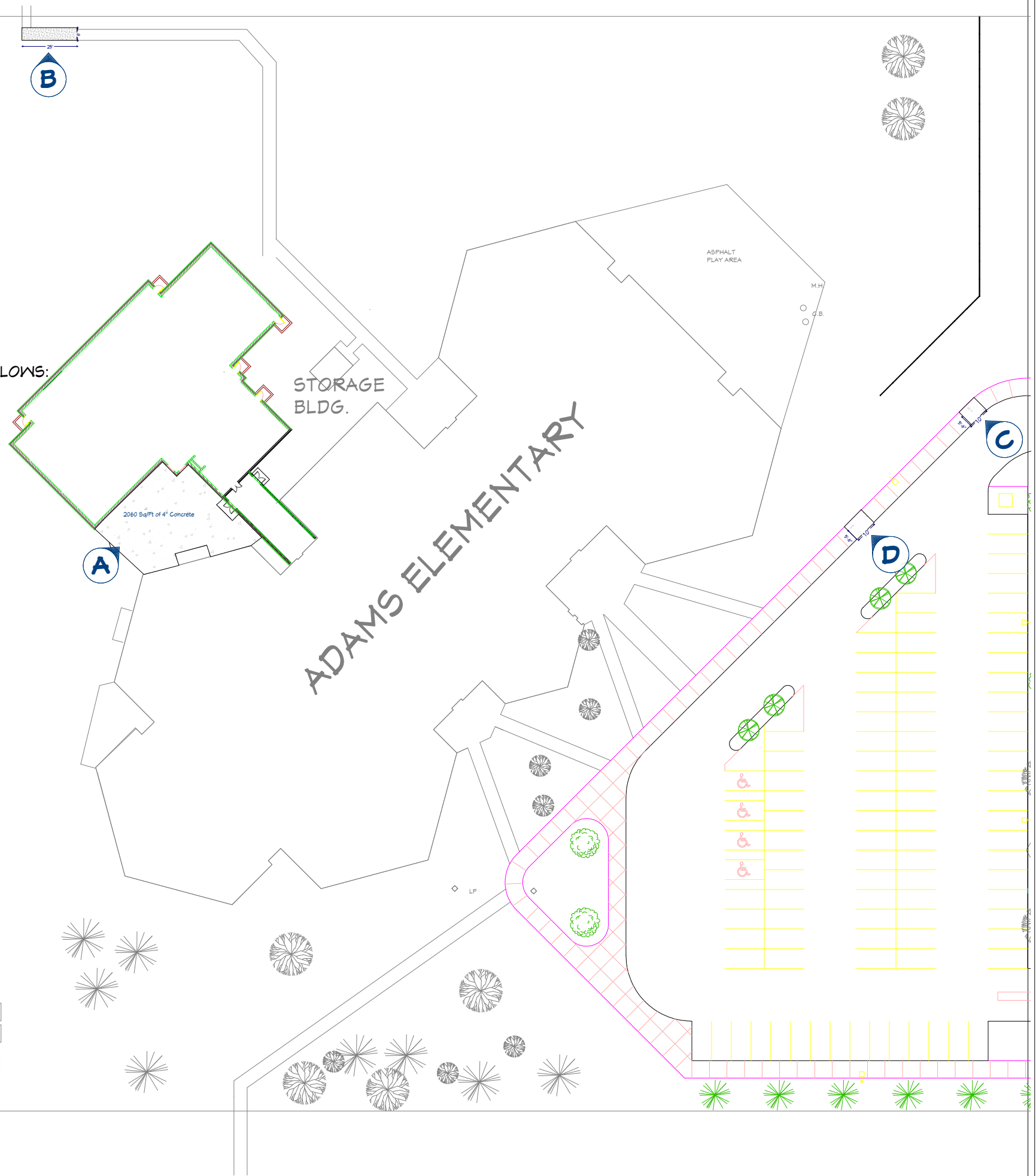

REVISION TABLE	
NUMBER	DATE

ADAMS ELEMENTARY
1005 ADAMS DR
MIDLAND, MICH 48642

DRAWINGS PROVIDED BY:
MIDLAND PUBLIC SCHOOLS
FACILITIES DEPARTMENT
989-923-5035

DATE:
3/5/2026

SCALE:

SHEET:
P-1

Concrete Repair 2025



Sidewalks Needing Repair

200ft

REVISION TABLE	
NUMBER	DATE

REVISION BY	DESCRIPTION

ADAMS ELEMENTARY
1005 ADAMS DR
MIDLAND, MICH 48642

DRAWINGS PROVIDED BY:
MIDLAND PUBLIC SCHOOLS
FACILITIES DEPARTMENT
989-923-5035

DATE:

3/5/2026

SCALE:

SHEET:

P-2

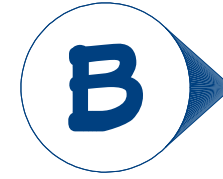

REVISION TABLE	
NUMBER	DATE

REVISION BY	DESCRIPTION

ADAMS ELEMENTARY
1005 ADAMS DR
MIDLAND, MICH 48642

DRAWINGS PROVIDED BY:
MIDLAND PUBLIC SCHOOLS
FACILITIES DEPARTMENT
989-923-5035

DATE:

3/5/2026

SCALE:

SHEET:

P-3

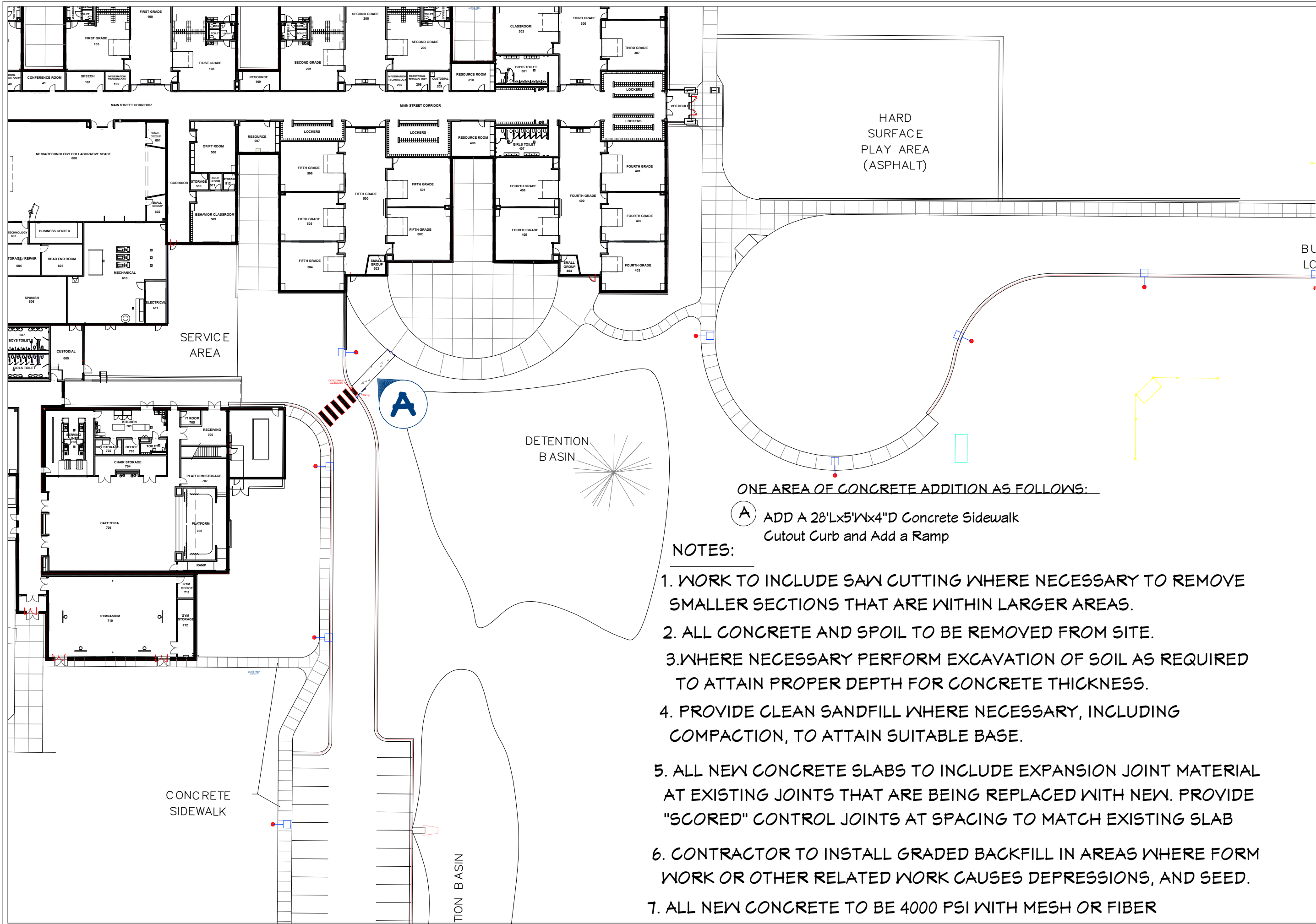

REVISION TABLE	NUMBER	DATE	REVISOR	DESCRIPTION

BU
LC

**CENTRAL PARK
ELEMENTARY
CONCRETE WORK**

DRAWINGS PROVIDED BY:
**MIDLAND PUBLIC SCHOOLS
FACILITIES DEPARTMENT**
989-923-5035

DATE:

3/5/2026

SCALE:

SHEET:

P-4

ONE AREA OF CONCRETE ADDITION AS FOLLOWS:

- (A) ADD A 28'Lx5'Wx4"D Concrete Sidewalk Cutout Curb and Add a Ramp

NOTES:

1. WORK TO INCLUDE SAW CUTTING WHERE NECESSARY TO REMOVE SMALLER SECTIONS THAT ARE WITHIN LARGER AREAS.
2. ALL CONCRETE AND SPOIL TO BE REMOVED FROM SITE.
3. WHERE NECESSARY PERFORM EXCAVATION OF SOIL AS REQUIRED TO ATTAIN PROPER DEPTH FOR CONCRETE THICKNESS.
4. PROVIDE CLEAN SANDFILL WHERE NECESSARY, INCLUDING COMPACTION, TO ATTAIN SUITABLE BASE.
5. ALL NEW CONCRETE SLABS TO INCLUDE EXPANSION JOINT MATERIAL AT EXISTING JOINTS THAT ARE BEING REPLACED WITH NEW. PROVIDE "SCORED" CONTROL JOINTS AT SPACING TO MATCH EXISTING SLAB
6. CONTRACTOR TO INSTALL GRADED BACKFILL IN AREAS WHERE FORM WORK OR OTHER RELATED WORK CAUSES DEPRESSIONS, AND SEED.
7. ALL NEW CONCRETE TO BE 4000 PSI WITH MESH OR FIBER

Concrete Repair 2025



NUMBER	DATE	REVISION	DESCRIPTION

CENTRAL PARK
ELEMENTARY
CONCRETE WORK

DRAWINGS PROVIDED BY:
MIDLAND PUBLIC SCHOOLS
FACILITIES DEPARTMENT
989-923-5035

DATE:
3/5/2026

SCALE:

SHEET:

P-5



REVISION TABLE	
NUMBER	DATE

CENTRAL PARK
ELEMENTARY
CONCRETE WORK

DRAWINGS PROVIDED BY:
MIDLAND PUBLIC SCHOOLS
FACILITIES DEPARTMENT
989-923-5035

DATE:

3/5/2026

SCALE:

SHEET:

P-6

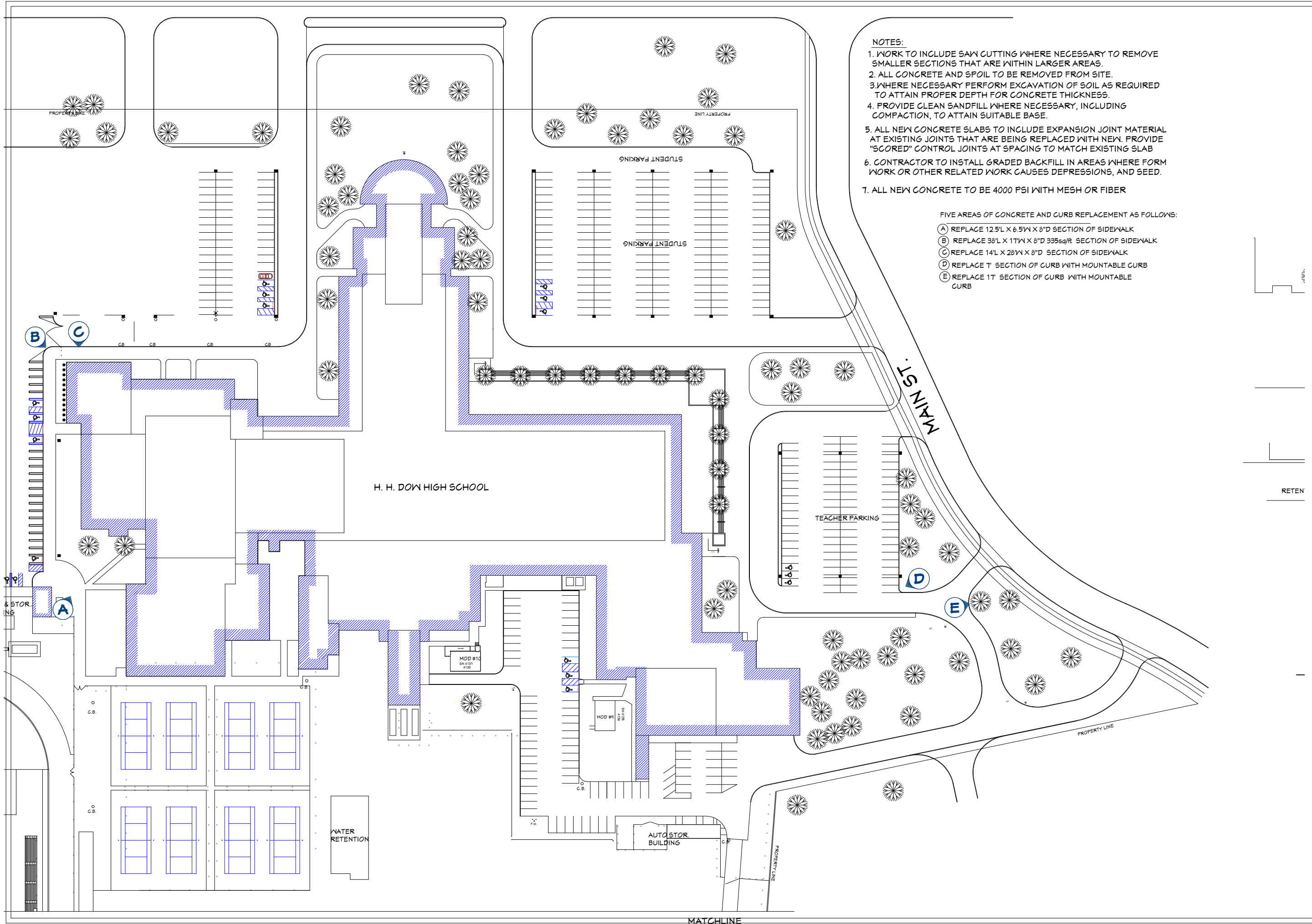

- NOTES:**
1. WORK TO INCLUDE SAW CUTTING WHERE NECESSARY TO REMOVE SMALLER SECTIONS THAT ARE WITHIN LARGER AREAS.
 2. ALL CONCRETE AND SPOIL TO BE REMOVED FROM SITE.
 3. WHERE NECESSARY PERFORM EXCAVATION OF SOIL AS REQUIRED TO ATTAIN PROPER DEPTH FOR CONCRETE THICKNESS.
 4. PROVIDE CLEAN SANDFILL WHERE NECESSARY, INCLUDING COMPACTION, TO ATTAIN SUITABLE BASE.
 5. ALL NEW CONCRETE SLABS TO INCLUDE EXPANSION JOINT MATERIAL AT EXISTING JOINTS THAT ARE BEING REPLACED WITH NEW. PROVIDE "SCORED" CONTROL JOINTS AT SPACING TO MATCH EXISTING SLAB
 6. CONTRACTOR TO INSTALL GRADED BACKFILL IN AREAS WHERE FORM WORK OR OTHER RELATED WORK CAUSES DEPRESSIONS, AND SEED.
 7. ALL NEW CONCRETE TO BE 4000 PSI WITH MESH OR FIBER

- FIVE AREAS OF CONCRETE AND CURB REPLACEMENT AS FOLLOWS:
- (A) REPLACE 12.5'L X 6.5'W X 8"D SECTION OF SIDEWALK
 - (B) REPLACE 38'L X 1'W X 8"D 335sq/ft SECTION OF SIDEWALK
 - (C) REPLACE 14'L X 28'W X 8"D SECTION OF SIDEWALK
 - (D) REPLACE 7' SECTION OF CURB WITH MOUNTABLE CURB
 - (E) REPLACE 17' SECTION OF CURB WITH MOUNTABLE CURB

REVISION TABLE	NUMBER	DATE	REVISOR	DESCRIPTION

**H. H. DOW HIGH SCHOOL
CONCRETE WORK**

DRAWINGS PROVIDED BY:
**MIDLAND PUBLIC SCHOOLS
FACILITIES DEPARTMENT
989-923-5035**

DATE:

3/5/2026

SCALE:

SHEET:

P-7

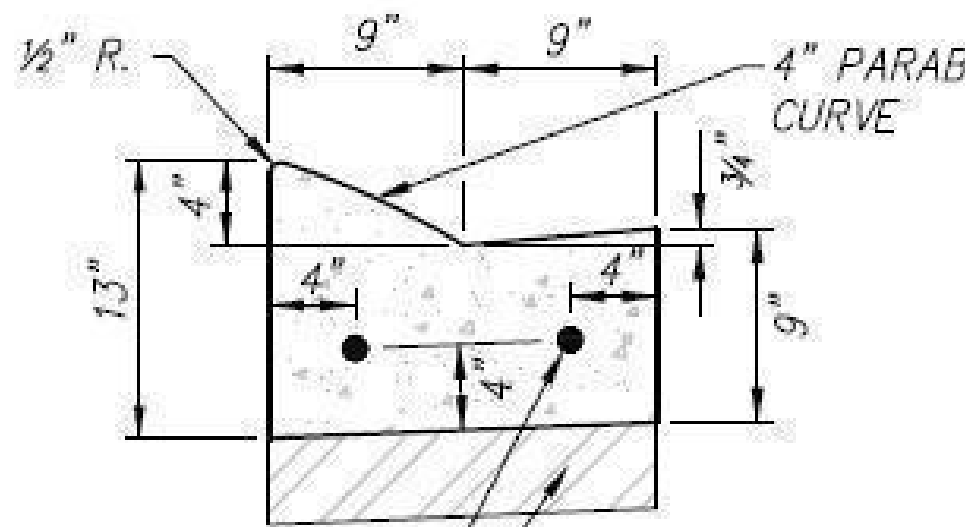

EPOXY COATED #4 BAR (TYP)
4" LIMESTONE AGG. BASE, 21AA

DETAIL

4" MOUNTABLE CURB & GUTTER STANDARD PAN

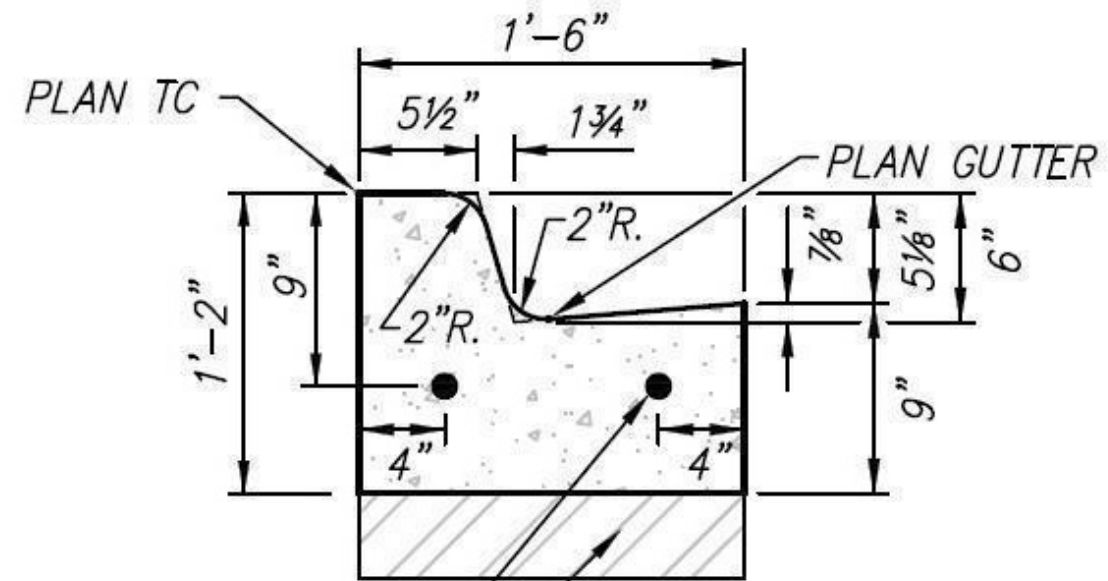

EPOXY COATED #4 BAR (TYP)
4" LIMESTONE AGG. BASE, 21AA

DETAIL

**6" CURB & GUTTER STANDARD PAN
(MDOT TYPE F1)**



REVISION TABLE	NUMBER	DATE	REVISION BY	DESCRIPTION

DRAWINGS PROVIDED BY:
MIDLAND PUBLIC SCHOOLS
FACILITIES DEPARTMENT
989-923-5035

DATE:

3/5/2026

SCALE:

SHEET:

P-8



--

NUMBER	DATE	REVISION TABLE	DESCRIPTION

**H. H. DOW HIGH SCHOOL
CONCRETE WORK**

DRAWINGS PROVIDED BY:
MIDLAND PUBLIC SCHOOLS
FACILITIES DEPARTMENT
989-923-5035

DATE:

3/5/2026

SCALE:

SHEET:

P-9



A



B



C



D

IMG_2535

REVISION TABLE	
NUMBER	DATE

**H. H. DOW HIGH SCHOOL
CONCRETE WORK**

DRAWINGS PROVIDED BY:
**MIDLAND PUBLIC SCHOOLS
FACILITIES DEPARTMENT
989-923-5035**

DATE:

3/5/2026

SCALE:

SHEET:

P-10



DRAWINGS PROVIDED BY:

MIDLAND PUBLIC SCHOOLS
FACILITIES DEPARTMENT
989-923-5035

DATE:

3/5/2026

SCALE:

SHEET:

P-11

H. H. DOW HIGH SCHOOL
CONCRETE WORK

REVISION TABLE

NUMBER	DATE	REVISED BY	DESCRIPTION

TWO PADS AS FOLLOWS:

A Add Two 20'Lx21'Wx6"D Concrete Pads

NOTES:

1. PERFORM EXCAVATION OF SOIL AS REQUIRED TO ATTAIN PROPER DEPTH FOR CONCRETE THICKNESS.
2. ALL CONCRETE AND SPOIL TO BE REMOVED FROM SITE.
3. PROVIDE CLEAN SANDFILL WHERE NECESSARY, INCLUDING COMPACTION, TO ATTAIN SUITABLE BASE.
4. ALL NEW CONCRETE SLABS TO INCLUDE EXPANSION JOINT MATERIAL AT EXISTING JOINTS THAT ARE BEING REPLACED WITH NEW. PROVIDE "SCORED" CONTROL JOINTS AT SPACING TO MATCH EXISTING SLAB
5. CONTRACTOR TO INSTALL GRADED BACKFILL IN AREAS WHERE FORM WORK OR OTHER RELATED WORK CAUSES DEPRESSIONS, AND SEED.
6. ALL NEW CONCRETE TO BE 4000 PSI WITH MESH OR FIBER

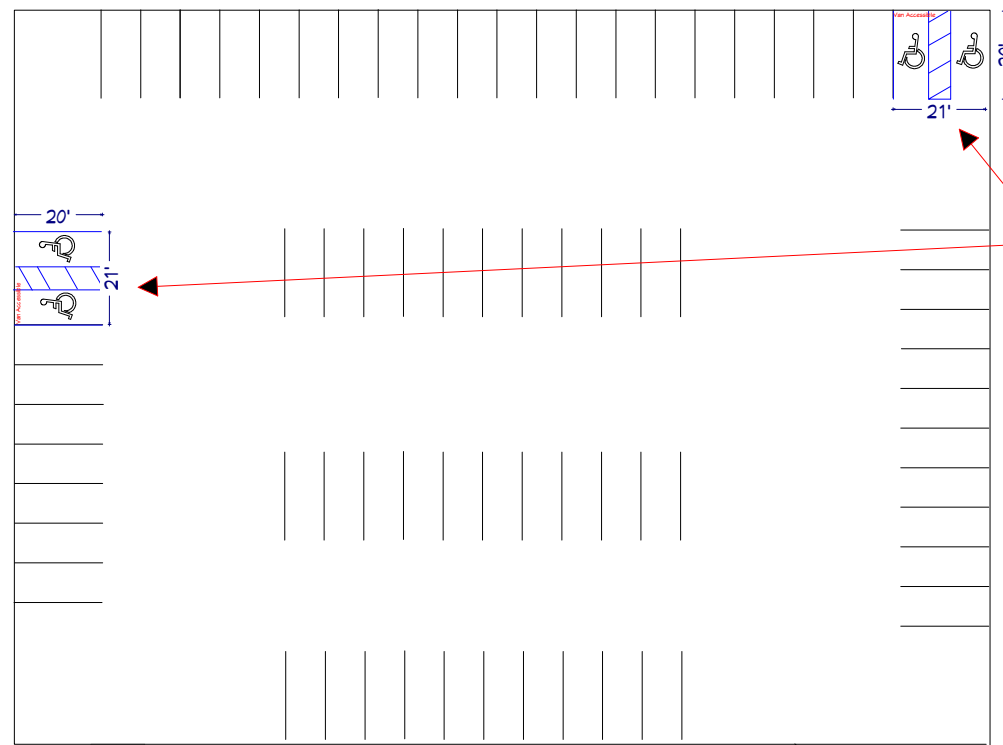
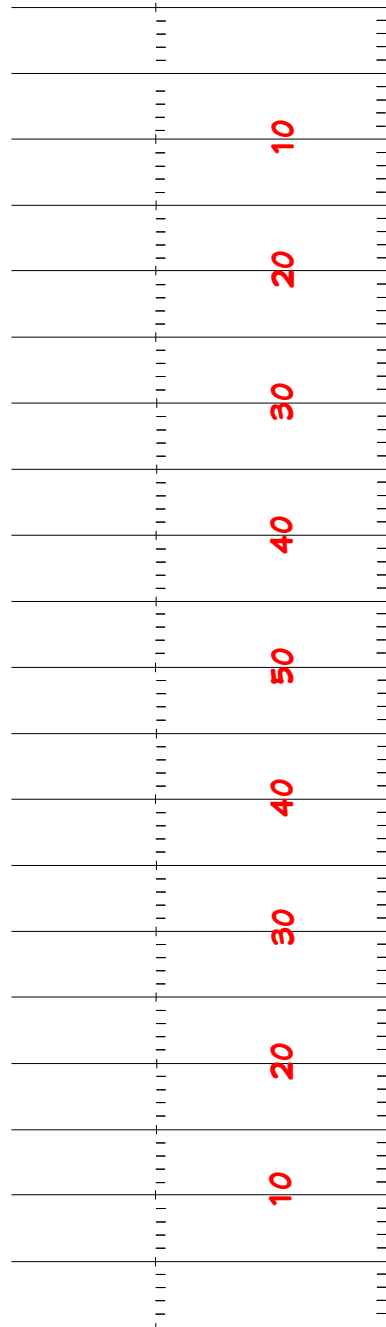

A
Four two 20'Lx21'Wx6"D Pads

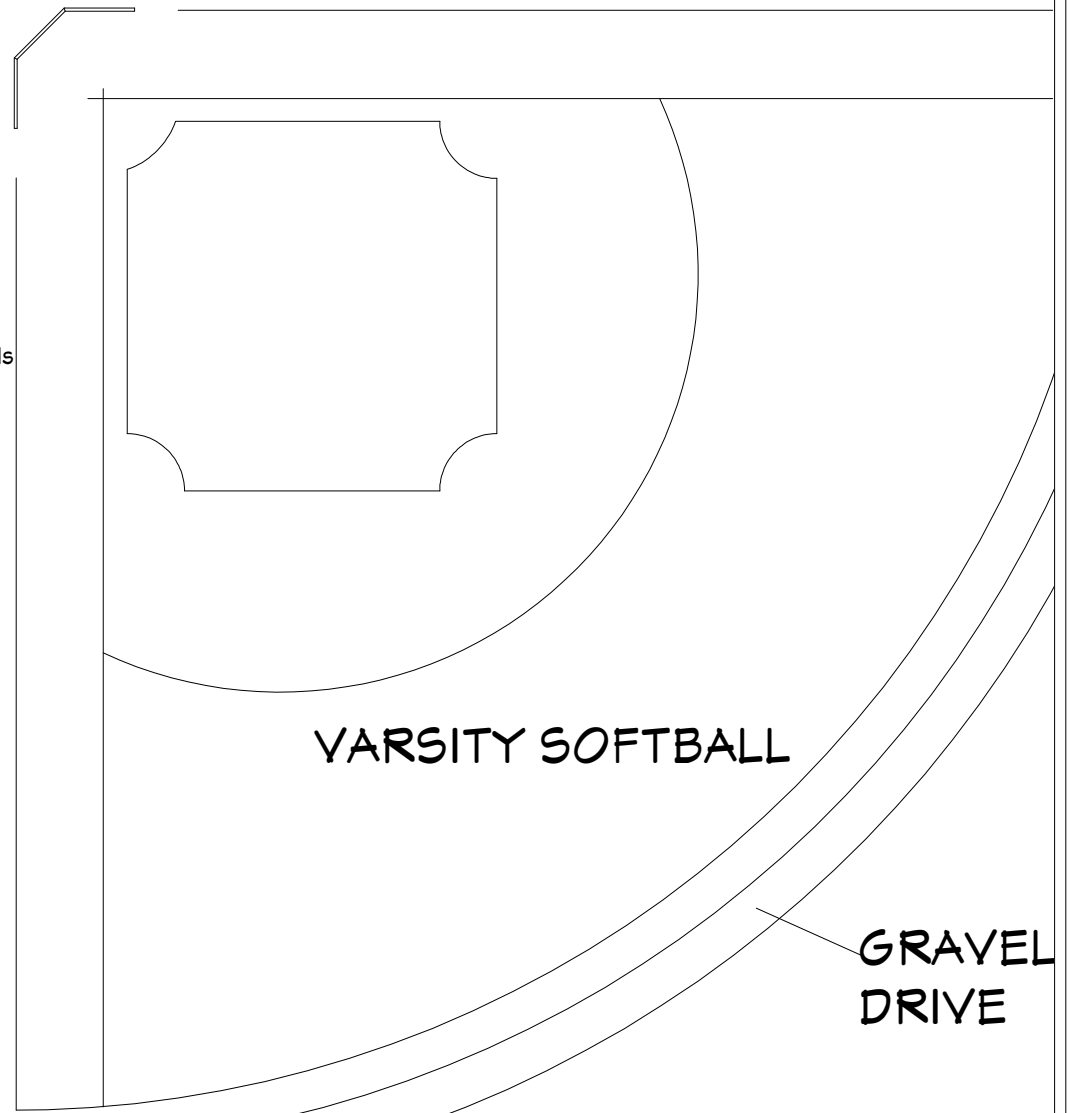

REVISION TABLE	NUMBER	DATE	REVISED BY	DESCRIPTION

H. H. DOW HIGH SCHOOL
SPORTS FIELD
CONCRETE WORK

DRAWINGS PROVIDED BY:
MIDLAND PUBLIC SCHOOLS
FACILITIES DEPARTMENT
989-923-5035

DATE:

3/5/2026

SCALE:

SHEET:

P-12



--	--

NUMBER	DATE	REVISION TABLE	REVISOR	DESCRIPTION

--

**H. H. DOW HIGH SCHOOL
SPORTS FIELD
CONCRETE WORK**

DRAWINGS PROVIDED BY:
MIDLAND PUBLIC SCHOOLS
FACILITIES DEPARTMENT
989-923-5035

DATE:

3/5/2026

SCALE:

SHEET:

P-13



REVISION TABLE

NUMBER	DATE	REVISED BY	DESCRIPTION

**H. H. DOW HIGH SCHOOL
SPORTS FIELD
CONCRETE WORK**

DRAWINGS PROVIDED BY:
**MIDLAND PUBLIC SCHOOLS
FACILITIES DEPARTMENT
989-923-5035**

DATE:

3/5/2026

SCALE:

SHEET:

P-14

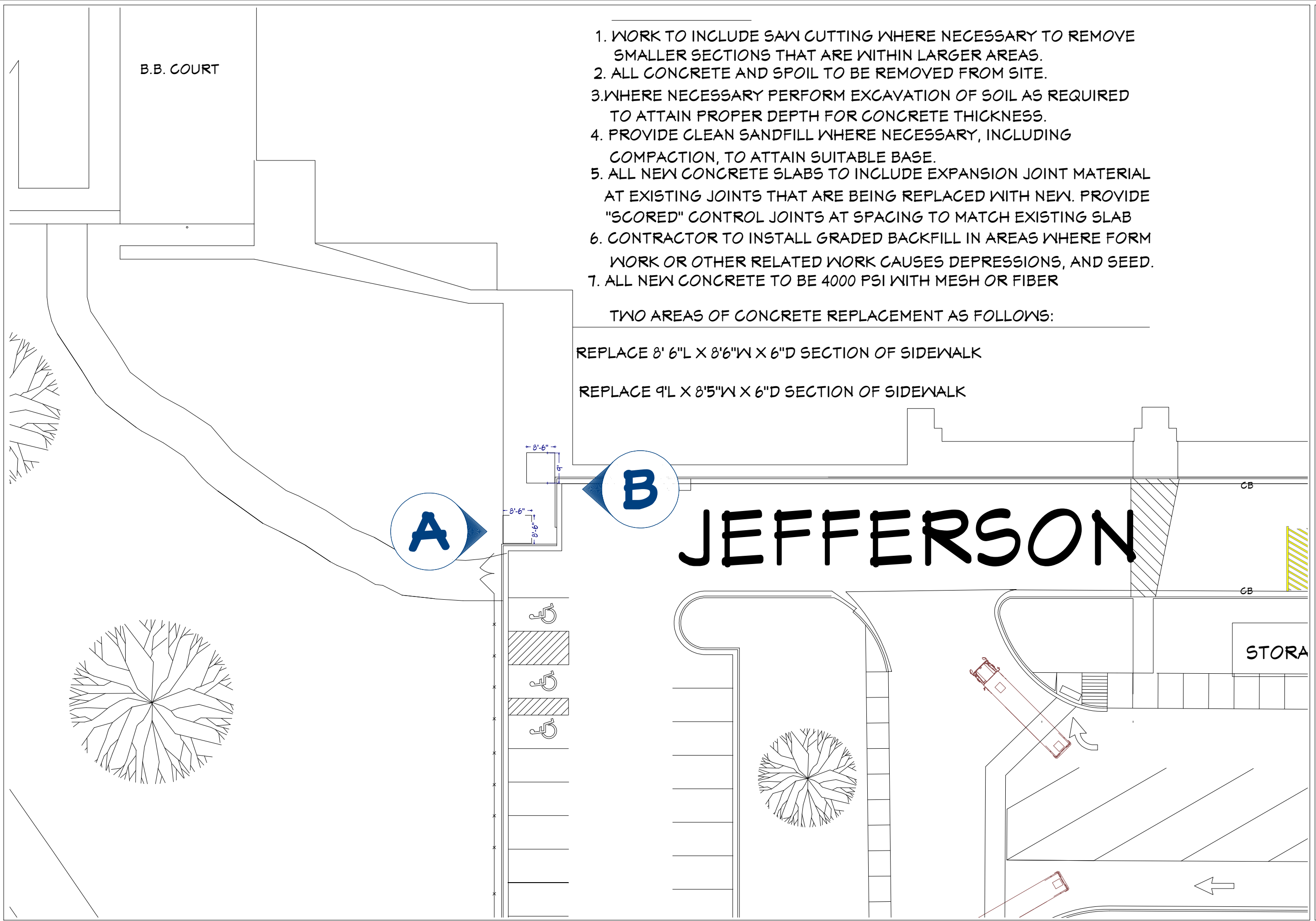

1. WORK TO INCLUDE SAW CUTTING WHERE NECESSARY TO REMOVE SMALLER SECTIONS THAT ARE WITHIN LARGER AREAS.
2. ALL CONCRETE AND SPOIL TO BE REMOVED FROM SITE.
3. WHERE NECESSARY PERFORM EXCAVATION OF SOIL AS REQUIRED TO ATTAIN PROPER DEPTH FOR CONCRETE THICKNESS.
4. PROVIDE CLEAN SANDFILL WHERE NECESSARY, INCLUDING COMPACTION, TO ATTAIN SUITABLE BASE.
5. ALL NEW CONCRETE SLABS TO INCLUDE EXPANSION JOINT MATERIAL AT EXISTING JOINTS THAT ARE BEING REPLACED WITH NEW. PROVIDE "SCORED" CONTROL JOINTS AT SPACING TO MATCH EXISTING SLAB
6. CONTRACTOR TO INSTALL GRADED BACKFILL IN AREAS WHERE FORM WORK OR OTHER RELATED WORK CAUSES DEPRESSIONS, AND SEED.
7. ALL NEW CONCRETE TO BE 4000 PSI WITH MESH OR FIBER

TWO AREAS OF CONCRETE REPLACEMENT AS FOLLOWS:

- REPLACE 8' 6"L X 8'6"W X 6"D SECTION OF SIDEWALK
- REPLACE 9'L X 8'5"W X 6"D SECTION OF SIDEWALK

REVISION TABLE	NUMBER	DATE	REVISOR	DESCRIPTION

JEFFERSON MIDDLE SCHOOL CONCRETE WORK

DRAWINGS PROVIDED BY:
MIDLAND PUBLIC SCHOOLS FACILITIES DEPARTMENT
989-923-5035

DATE: 3/5/2026

SCALE:

SHEET: P-15

Concrete Repair 2025

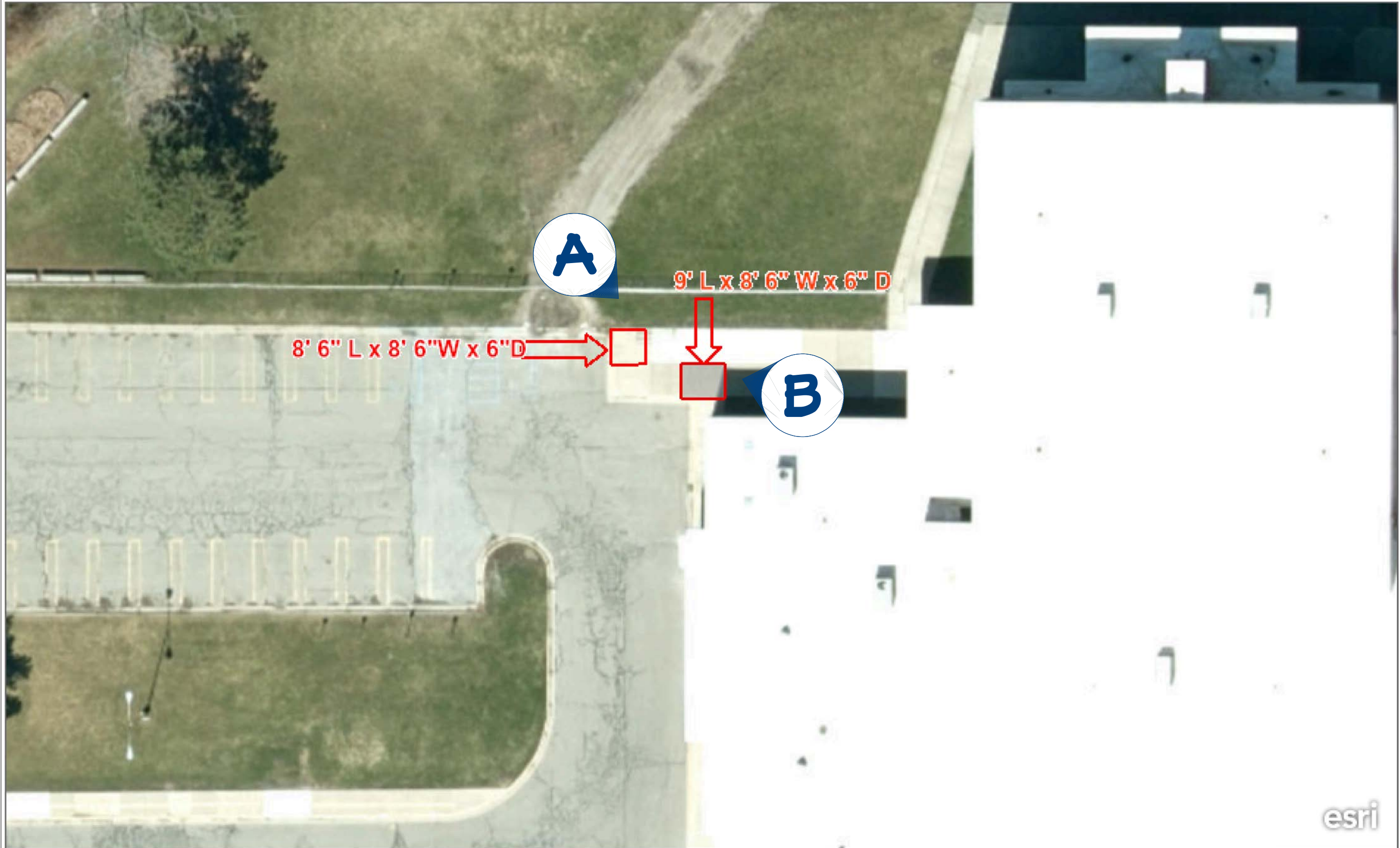

REVISION TABLE	
NUMBER	DATE

JEFFERSON MIDDLE SCHOOL
CONCRETE WORK

DRAWINGS PROVIDED BY:
MIDLAND PUBLIC SCHOOLS
FACILITIES DEPARTMENT
989-923-5035

DATE:

3/5/2026

SCALE:

SHEET:

P-16





REVISION TABLE	
NUMBER	DATE

JEFFERSON MIDDLE
SCHOOL
CONCRETE WORK

DRAWINGS PROVIDED BY:
MIDLAND PUBLIC SCHOOLS
FACILITIES DEPARTMENT
989-923-5035

DATE:

3/5/2026

SCALE:

SHEET:

P-17

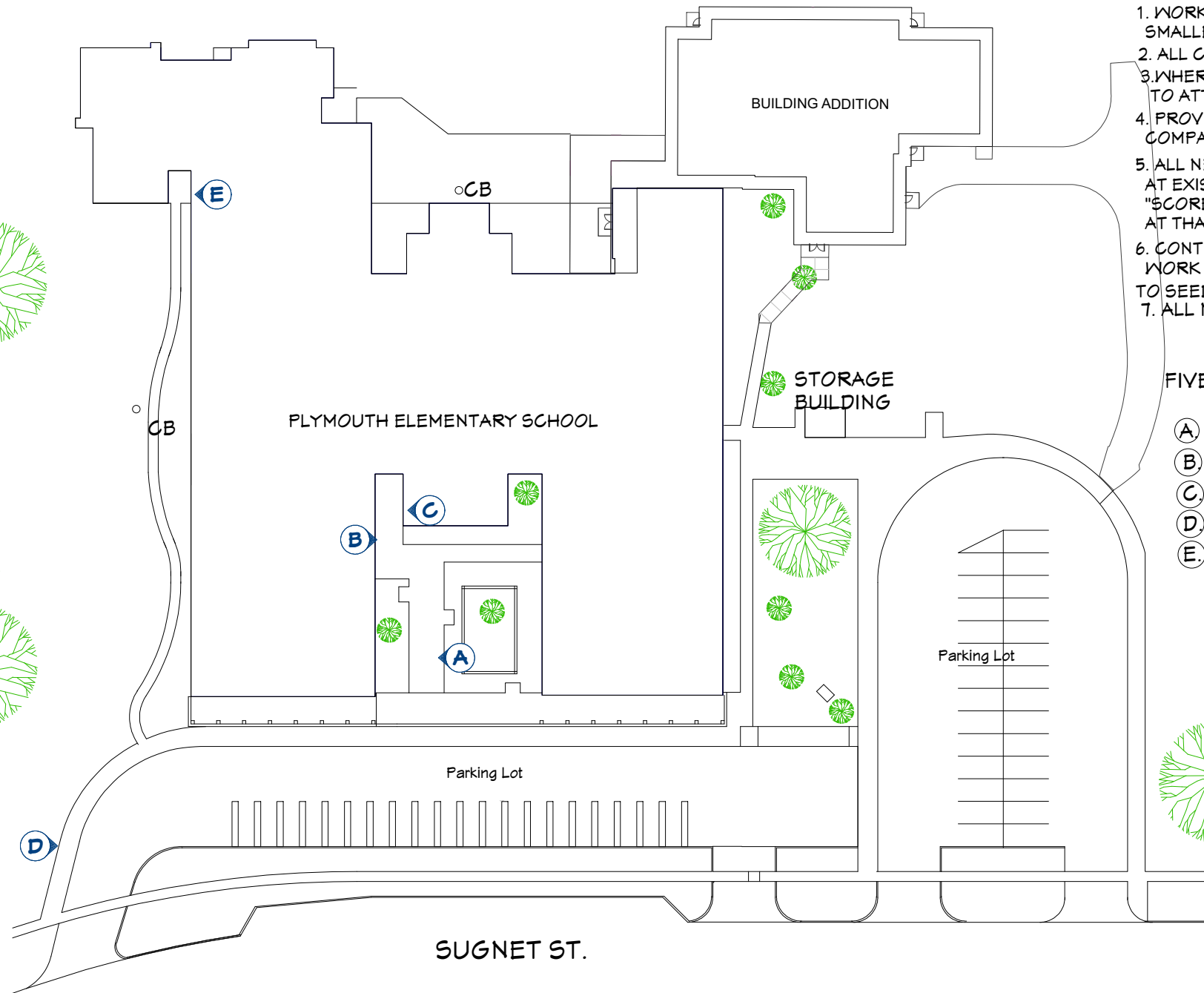
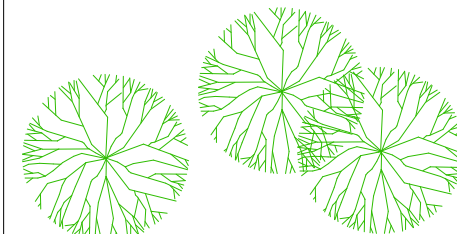
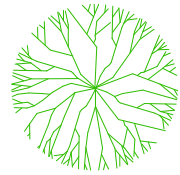
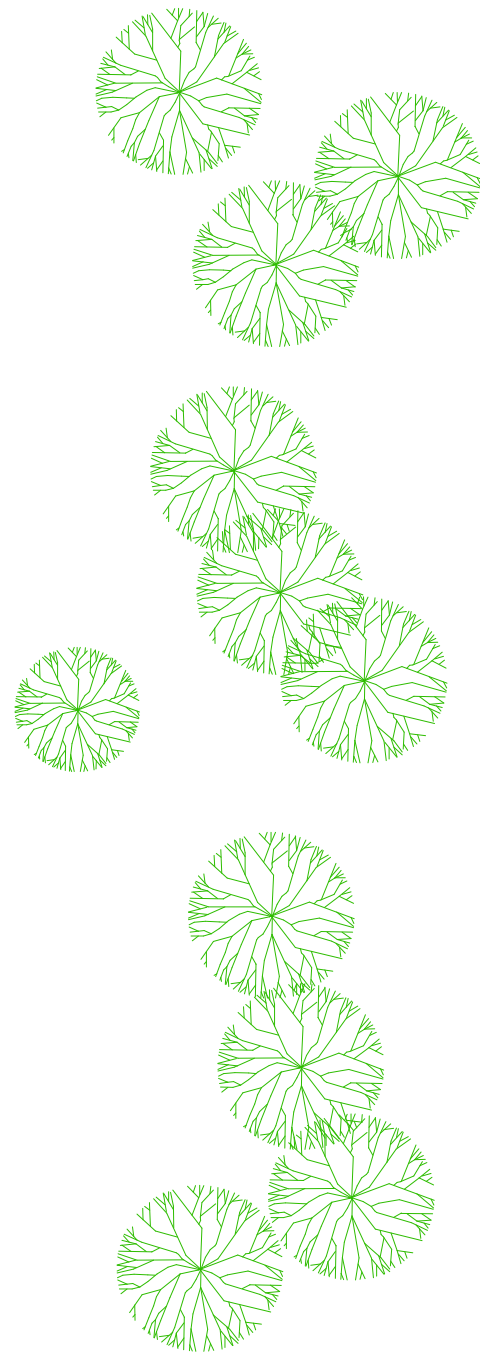

NOTES:

1. WORK TO INCLUDE SAW CUTTING WHERE NECESSARY TO REMOVE SMALLER SECTIONS THAT ARE WITHIN LARGER AREAS.
2. ALL CONCRETE AND SPOIL TO BE REMOVED FROM SITE.
3. WHERE NECESSARY PERFORM EXCAVATION OF SOIL AS REQUIRED TO ATTAIN PROPER DEPTH FOR CONCRETE THICKNESS.
4. PROVIDE CLEAN SANDFILL WHERE NECESSARY, INCLUDING COMPACTION, TO ATTAIN SUITABLE BASE.
5. ALL NEW CONCRETE SLABS TO INCLUDE EXPANSION JOINT MATERIAL AT EXISTING JOINTS THAT ARE BEING REPLACED WITH NEW. PROVIDE "SCORED" CONTROL JOINTS AT SPACING TO MATCH EXISTING SLAB AT THAT AREA.
6. CONTRACTOR TO INSTALL GRADED BACKFILL IN AREAS WHERE FORM WORK OR OTHER RELATED WORK CAUSES DEPRESSIONS. CONTRACTOR TO SEED.
7. ALL NEW CONCRETE TO BE 4000 PSI WITH MESH OR FIBER

FIVE AREAS OF REPLACEMENT AS FOLLOWS:

- (A) 7'L X 14'6"W X 4"D SECTION OF SIDEWALK
- (B) 7'6"L X 7'W X 4"D SECTION OF SIDEWALK
- (C) 15'L X 7'W X 4"D SECTION OF SIDEWALK
- (D) 15'L X 8'W X 6"D SECTION OF SIDEWALK
- (E) 15'L X 10'W X 4"D SECTION OF SIDEWALK

SITE PLAN

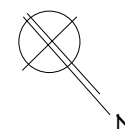

REVISION TABLE	NUMBER	DATE	REVISED BY	DESCRIPTION

PLYMOUTH ELEMENTARY SCHOOL
CONCRETE WORK

DRAWINGS PROVIDED BY:
MIDLAND PUBLIC SCHOOLS
FACILITIES DEPARTMENT
 989-923-5035

DATE:

3/5/2026

SCALE:

SHEET:

P-18



--	--

REVISION TABLE	NUMBER	DATE	REVISOR	DESCRIPTION

**PLYMOUTH ELEMENTARY
SCHOOL
CONCRETE WORK**

DRAWINGS PROVIDED BY:
MIDLAND PUBLIC SCHOOLS
FACILITIES DEPARTMENT
989-923-5035

DATE:

3/5/2026

SCALE:

SHEET:

P-19



A



B



C



D

REVISION TABLE	
NUMBER	DATE

DESCRIPTION

PLYMOUTH ELEMENTARY
SCHOOL
CONCRETE WORK

DRAWINGS PROVIDED BY:
MIDLAND PUBLIC SCHOOLS
FACILITIES DEPARTMENT
989-923-5035

DATE:

3/5/2026

SCALE:

SHEET:

P-20

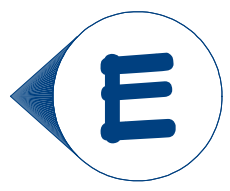

DRAWINGS PROVIDED BY:
MIDLAND PUBLIC SCHOOLS
FACILITIES DEPARTMENT
989-923-5035

DATE:

3/5/2026

SCALE:

SHEET:

P-21

PLYMOUTH ELEMENTARY
SCHOOL
CONCRETE WORK

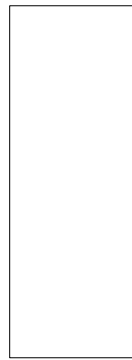

REVISION TABLE	NUMBER	DATE	REVISED BY	DESCRIPTION



MHS
DRIVERS ED
RANGE

NOTES:

1. WORK TO INCLUDE SAW CUTTING WHERE NECESSARY TO REMOVE SMALLER SECTIONS THAT ARE WITHIN LARGER AREAS.
2. ALL CONCRETE AND SPOIL TO BE REMOVED FROM SITE.
3. WHERE NECESSARY PERFORM EXCAVATION OF SOIL AS REQUIRED TO ATTAIN PROPER DEPTH FOR CONCRETE THICKNESS.
4. PROVIDE CLEAN SANDFILL WHERE NECESSARY, INCLUDING COMPACTION, TO ATTAIN SUITABLE BASE.
5. ALL NEW CONCRETE SLABS TO INCLUDE EXPANSION JOINT MATERIAL AT EXISTING JOINTS THAT ARE BEING REPLACED WITH NEW. PROVIDE "SCORED" CONTROL JOINTS AT SPACING TO MATCH EXISTING SLAB AT THAT AREA.
6. CONTRACTOR TO INSTALL GRADED BACKFILL IN AREAS WHERE FORM WORK OR OTHER RELATED WORK CAUSES DEPRESSIONS, AND SEED AFFECTED AREAS.
7. ALL NEW CONCRETE TO BE 4000 PSI WITH MESH OR FIBER

FIVE AREAS OF SIDEWALK REPLACEMENT AS FOLLOWS:

- (A) Replace 325 Sq/ft OF SIDEWALK INCLUDING ADA RAMP AND
- (B) REPLACE 14' OF CURB
- (C) REPLACE 96' OF CURBING WITH MOUNTABLE CURBS
- (D) REPLACE A 96'L X 6'W X 4"D SECTION OF SIDEWALK
- (E) REPLACE A 125'L X 6'W X 4"D SECTION OF SIDEWALK
- (F) REPLACE 93' OF CURBING WITH MOUNTABLE CURBS
- (G) REPLACE 26' OF CURBING WITH MOUNTABLE CURBS

SITE PLAN

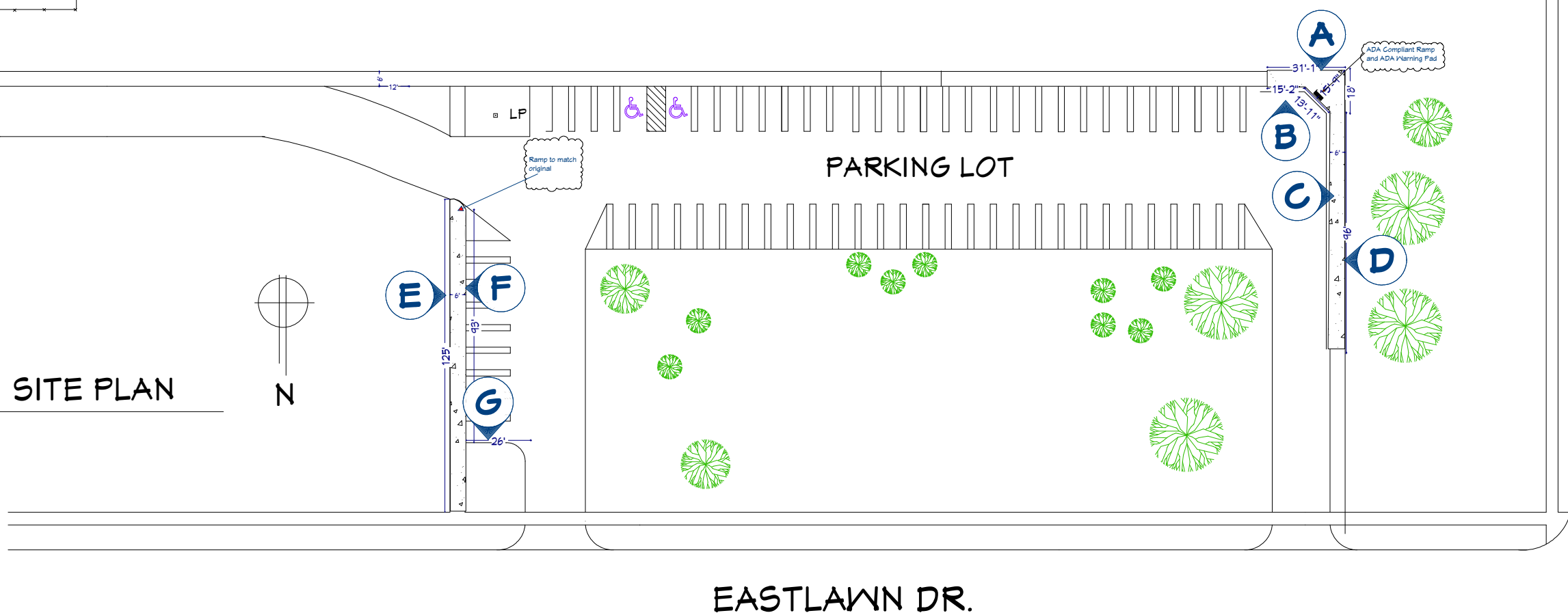
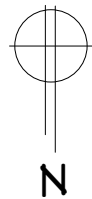

SUEDE RD.

EASTLAWN DR.

REVISION TABLE	NUMBER	DATE	REVISION BY	DESCRIPTION

MIDLAND HIGH SCHOOL
CONCRETE WORK

DRAWINGS PROVIDED BY:
MIDLAND PUBLIC SCHOOLS
FACILITIES DEPARTMENT
989-923-5035

DATE:

3/5/2026

SCALE:

SHEET:

P-22

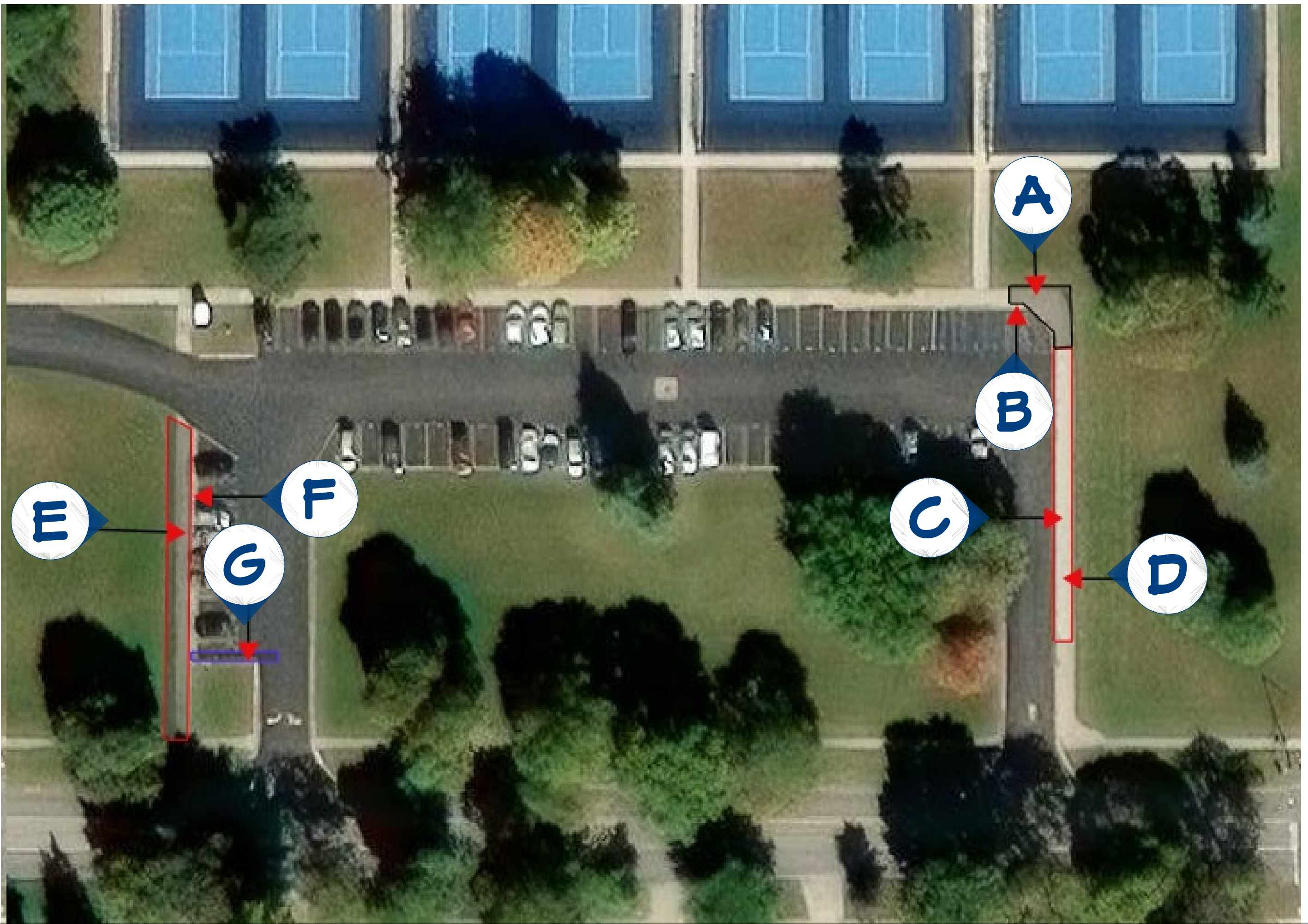

REVISION TABLE	
NUMBER	DATE

**MIDLAND HIGH SCHOOL
CONCRETE WORK**

DRAWINGS PROVIDED BY:
**MIDLAND PUBLIC SCHOOLS
 FACILITIES DEPARTMENT**
 989-923-5035

DATE:	
DATE:	3/5/2026
SCALE:	
SHEET:	P-23



A



B



C

D

REVISION TABLE	NUMBER	DATE	REVISION BY	DESCRIPTION

MIDLAND HIGH SCHOOL
CONCRETE WORK

DRAWINGS PROVIDED BY:
MIDLAND PUBLIC SCHOOLS
FACILITIES DEPARTMENT
989-923-5035

DATE:

3/5/2026

SCALE:

SHEET:

P-24



--

NUMBER	DATE	REVISION	DESCRIPTION

--

MIDLAND HIGH SCHOOL
CONCRETE WORK

DRAWINGS PROVIDED BY:
MIDLAND PUBLIC SCHOOLS
FACILITIES DEPARTMENT
989-923-5035

DATE:

3/5/2026

SCALE:

SHEET:

P-25

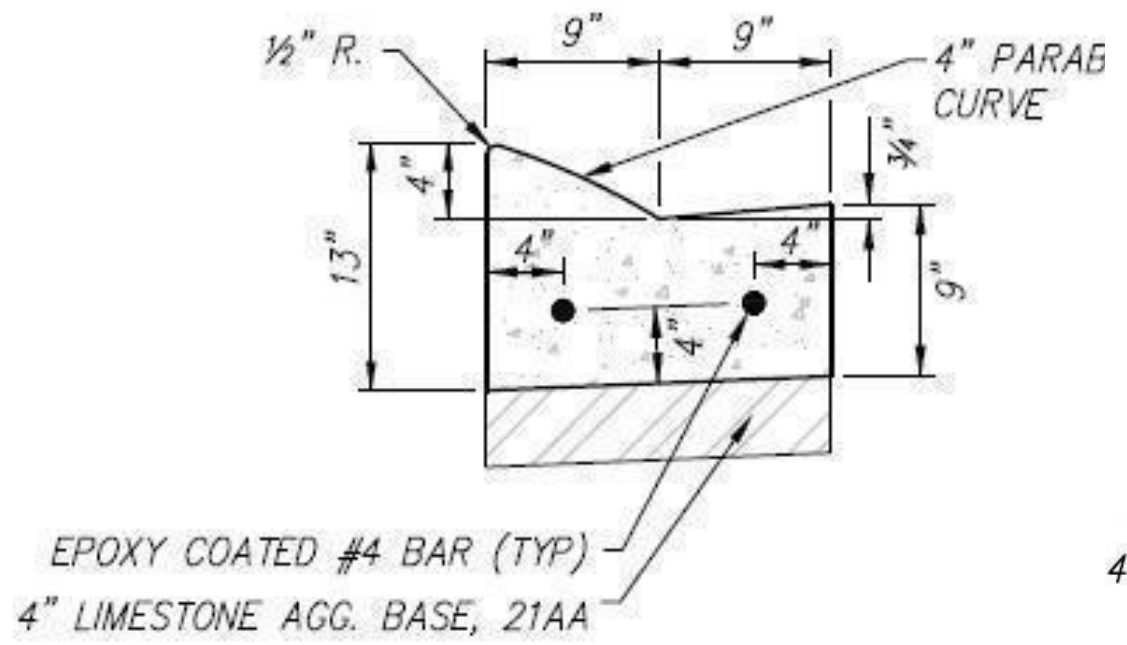

DETAIL
 4" MOUNTABLE CURB & GUTTER STANDARD PAN

A
P-22

Attic

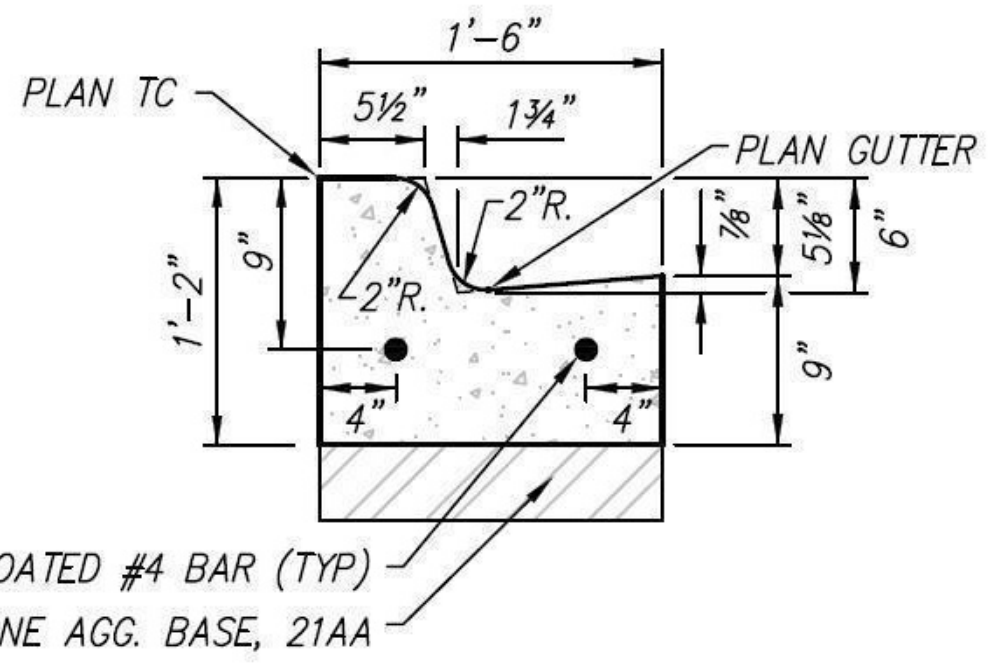

DETAIL
 6" CURB & GUTTER STANDARD PAN
 (MDOT TYPE F1)

C, F, G
P-22

REVISION TABLE	NUMBER	DATE	REVISION BY	DESCRIPTION

MIDLAND HIGH SCHOOL
 CONCRETE WORK

DRAWINGS PROVIDED BY:
 MIDLAND PUBLIC SCHOOLS
 FACILITIES DEPARTMENT
 989-923-5035

DATE:

3/5/2026

SCALE:

SHEET:

P-26

Better² Enterprises

Bid Form

Adams Elementary
1005 Adams Dr.
Midland, Michigan 48642

Area A \$21,600

Area B,C,D \$3,980

Total \$25,580

Central Park Elementary
1400 Rodd St,
Midland Michigan 48640

Total \$4,400

Herbert Henry Dow High School
3901 N. Saginaw Rd
Midland, Michigan 48640

Total \$31,747.25

Plymouth Elementary
1105 E. Sugnet Rd
Midland, Michigan 48642

Total \$8,055

Jefferson Middle School
800 W. Chapel Ln
Midland, Michigan 48640

Total \$2,380

Northeast Middle School
1305 E. Sugnet Rd
Midland Michigan 48642

Total \$0 _____

Midland High School
1301 Eastlawn Dr.
Midland Michigan 48640

Total \$34,525 _____

Price Per Cu/Yd Installed \$~1,215 _____

Please Describe Scope of Work to Include Time Frame of Work

Estimated time frame to complete all work stated in proposal at all locations
would be 1 month

Company Better2Enterprises

Title Owner

Phone # 810-397-5000

Email stevehoadley2016@gmail.com

Contact Person Steve Hoadley

My signature certifies that the proposal as submitted complies with all Terms and Conditions as set forth in this RFP.

Signature 

Iran Economic Sanctions Act Certification

I am the Owner (insert title) of Better2Enterprises (insert bidder company name), or I am bidding in my individual capacity ("Bidder"), with authority to submit a binding bid for the provision concrete services to Midland Public Schools. I have personal knowledge of the matters described in this Certification, and I am familiar with the Iran Economic Sanctions Act, MCL 129.311, et seq. ("Act"). I am fully aware that the school district will rely on my representations in evaluating bids.

I certify that Bidder is not an Iran-linked business, as that term is defined in the Act. I understand that submission of a false certification may result in contract termination, ineligibility to bid for three (3) years, and a civil penalty of \$250,000 or twice the bid amount, whichever is greater, plus related investigation and legal costs.

Signature  _____

Affidavit of Bidder-Compliance with School Safety Initiative Legislation

The undersigned, the owner or authorized officer of Better2Enterprises (the "Bidder"), certifies to Midland Public Schools (the "School District"), that any and all persons who will work directly or indirectly for the Bidder, including, but not limited to, Bidder's employees, agents, vendors, subcontractors or consultants, and who will work at or on any School District property, shall at all times be in compliance with MCL 380.1230, 380.1230a, 380.1230c, 380.1230d, and 380.1230g and have not been convicted of any "listed offenses".¹ The Bidder further warrants and represents that all persons who will work directly or indirectly for the Bidder, including, but not limited to, Bidder's employees, agents, vendors, subcontractors or consultants, and who will work at or on any School District property, shall at all times be in compliance with MCL 380.1230, 380.1230a, 380.1230c, 380.1230d, and 380.1230g. In this regard, Bidder agrees, without limitation, to report within 3 business days to the School District when any such person is charged with a crime listed in Section 1535a(1) of the Revised School Code² or a substantially similar law, and to immediately report to the School District if that person is subsequently convicted, plead guilty or plead no contest to that crime.

BIDDER: Better2Enterprises

By: Steve Hoadley 

Its: Owner

Affidavit of Bidder –Familial Relationships Form

The undersigned, the owner or authorized officer of Better2Enterprises _____ (the “Bidder”), pursuant to the familial disclosure requirement provided in the Midland Public Schools _____ (the “School District”) advertisement for construction bids, hereby represent and warrant, except as provided below, that no familial relationships exist between the bidder(s) or any employee of Better2Enterprises _____, and any member of the Board of Education of the School District or the Superintendent of the School District.

List any Familial Relationships:

None

BIDDER: Better2Enterprises _____

By: Steve Hoadley _____ 3-23-26

Its: Owner _____

STATE OF MICHIGAN)
)ss.
COUNTY OF Genesee)

This instrument was acknowledged before me on the 23rd day of March, 2026, by Steve Hoadley.

JULIA MIECZKOWSKI
NOTARY PUBLIC - STATE OF MICHIGAN
COUNTY OF GENESEE
My Commission Expires September 27, 2030
Acting in the County of Genesee

Julia Mieczkowski
Julia Mieczkowski, Notary Public
Genesee County, Michigan
My Commission Expires: 27-Sep-2030
Acting in the County of: Genesee

Genesee

9. 5. For Action: Fast Ice Camera Bid (Wamack)

Recommendation

Administration recommends approving a purchase order to Mobile Communications America (MCA) of Troy, MI, for \$77,412.40 for video security equipment for the new facility at Fast Ice Drive. This equipment includes nine 270-degree and nine 360-degree multi-sensor cameras, twelve indoor IR dome cameras, eight outdoor dual-head cameras, and 38 Enterprise camera channel licenses. This will provide comprehensive video surveillance and safety monitoring throughout and around the building. The pricing provided by MCA was secured through the REMC bid, ensuring compliance with Board purchasing policy. The expenditure will be paid for through 31aa Mental Health & Safety Grant funds.

Supporting Documents



[_Estimate_4503917 - Avigilon Video Parts - REMC](#)

Midland Public Schools, MI

Avigilon Video Parts - REMC

Q4190000578

Provided By:



Matt Camps

mattcamps@callmc.com

Table of Contents

[Bill of Materials](#)

[System Investment](#)

[Payment Terms](#)

[Customer Acceptance](#)

DCJS No.: 11-17936 and NC 2610-CSA

VA DCJS # 11-17936

CONFIDENTIALITY STATEMENT

THIS DOCUMENT CONTAINS INFORMATION THAT IS CONFIDENTIAL PERTAINING TO MOBILE COMMUNICATIONS AMERICA, INC. (MCA), THE SECURITY, FACILITIES, IT AND OTHER DEPARTMENTS OF THE REVIEWING ORGANIZATION. IT SHALL BE NEITHER DUPLICATED NOR DISCLOSED TO ANY PERSON OR PERSONS OUTSIDE THE RESPECTIVE COMPANIES WITHOUT PRIOR WRITTEN CONSENT.

MCA FURTHER AGREES TO MAINTAIN COMPLETE CONFIDENTIALITY AND AGREES ANY INFORMATION FURNISHED WILL BE KEPT IN THE STRICTEST CONFIDENCE. MCA WILL FURTHER NOT DISCLOSE TO ANYONE WHO IS NOT A DIRECT PARTICIPANT IN THE POSSIBLE PROJECT, THE FACT THAT NEGOTIATIONS ARE TAKING PLACE OR ANY TERMS OF THE POSSIBLE TRANSACTION.

Date:
2/24/2026

Quote:
Q4190000578

Expiration Date:
5/25/2026

Bill of Materials

SKU	Unit Price	Quantity	Row Total
138057	\$1,753.64	9	\$15,782.76
3X8MP; WDR; 270 degree max field of view; Lightcatcher; 3.3-5.7MM; Camera Only			
138058	\$2,094.31	9	\$18,848.79
4X8MP; WDR; 360 degree max field of view; Lightcatcher; 3.3-5.7MM; Camera Only			
143869	\$1,099.49	12	\$13,193.88
8MP H6A Indoor IR Dome Camera with 4.4-9.3mm Lens			
186142	\$1,422.23	8	\$11,377.84
Avigilon 16.0C-H6ADH-DO1-IR 2x 8MP H6A Dual Head Camera. Outdoor camera with built-in IR			
137758	\$131.82	7	\$922.74
Outdoor pendant mount adapter. For use with the Avigilon H5A Multisensor			
136652	\$76.07	7	\$532.49
Wall Mount for large pendant camera			
58547	\$257.59	7	\$1,803.13
Optional IR illuminator ring; up to 30m (100ft); for use with H4AMH-DO-COVR1.			
137756	\$95.92	7	\$671.44
CORNER MNT FOR LRGE PENDT WLMT-1001			
137761	\$131.82	18	\$2,372.76
Dome bubble and cover; for outdoor surface mount or pendant mount; clear. For use with the Avigilon H5A Multisensor			
137775	\$117.09	18	\$2,107.62
Gigabit 802.3bt 60 W PoE Injector; Indoor; single port			
137757	\$131.82	11	\$1,450.02
Outdoor surface mount adapter. For use with the Avigilon H5A Multisensor			
141835	\$117.09	5	\$585.45
In-ceiling adapter; must order either a H5AMH-DC-COVR1 or H5AMH-DC-COVR1-SMOKE.			
183362	\$46.31	2	\$92.62
Avigilon NPTA-1201 1.5 inch NPT Adapter for Dual Head Cameras			
143868	\$46.83	2	\$93.66
Mount; Pendant Arm; 20cm Long; 1.5 NPT			

Date:
2/24/2026

Quote:
Q4190000578

Expiration Date:
5/25/2026

SKU	Unit Price	Quantity	Row Total
218319	\$199.40	38	\$7,577.20
Avigilon UNITY8-ENT Unity Enterprise camera channel			

Subtotal: \$77,412.40

System Investment

Purchase Price, Excluding Taxes:	\$77,412.40
Estimated Taxes:	\$0.00
Purchase Price, Including Taxes:	\$77,412.40

Payment Terms

Payment Terms:

Except as provided below, all contracted services require payment in full, due upon receipt of invoice. Installation contracts or services in excess of \$5,000 require:

1. 30% down payment.
2. 100% payment of stored materials upon receipt at MCA's warehouse. Inspection of billed products by Customer at MCA's warehouse will be permitted
3. Progress labor billing will occur each month based upon the percentage of completion of whole project up to 90% of total labor charges.
4. Final charges will be billed upon final completion of the job. All billings shall be net due upon receipt of invoice.

All credit card payments are subject to a 2% convenience fee

Delinquent Accounts - 18% APR will be added to Invoice(s) that are more than 7 days past due. The 18% APR will be applied on a monthly basis.

Contact cashapp@callmc.com for a remittance address that allows receipt tracking.

Customer is responsible for all taxes; except if the Customer represents that it is tax exempt under sections 501(a) and 501(c) of the Internal Revenue Code of the United States, and under the applicable laws of any State due any tax. If Customer represents that all sales, use or business taxes or personal property taxes and all fees imposed by municipal, state, and/or federal authorities in connection with the systems and services to be performed or sold by MCA are tax exempt, then Customer agrees to hold MCA harmless from and to indemnify MCA against any of the foregoing charges if the exempt status is incorrect, discontinued, or modified.

Credit card payments by customers, may be subject to convenience fees, in MCA's sole and absolute discretion.

Assumptions:

MCA's proposal is based on the basic investigation of your site together with the available information provided. MCA's goal is to provide the system solution desired; however, MCA reserves the right to make adjustments should we discover that material facts or circumstances relating to the project or specification have been omitted or inadvertently missed at the time of project design, engineering, or during the installation. All adjustments will be formally documented on a revised MCA proposal document if the job has not commenced; or a MCA "Additional Work Authorization" or "Change Order" document if the adjustments are discovered after the work has begun. These documents will be presented for your review and approval.

Post-Installation Service and Support:

Each item of equipment purchased under this agreement is covered by the manufacturer's warranty. MCA's sole warranty is for its labor which is warranted for 90 days on new equipment and services. Warranty will begin upon completion of the installation, or at a time where "beneficial use" of the system occurs; or of any of its' component sub-systems. Upon request, MCA can also provide a customized maintenance plan that fits the customers application and budget. Our value-added service

maintenance plans can include all parts and labor to correct system failures, as well as a preventative maintenance program to minimize system downtime.

Customer Acceptance

IN WITNESS WHEREOF, the Parties hereto execute and accept this proposal and agree to be bound by all parts, including the terms and conditions, which together form the complete agreement (hereinafter the "Agreement") between the Parties. The terms and conditions are incorporated by reference as fully set forth herein and available at [Terms and Conditions](#) (the "Terms"). This Agreement is in effect on the date proposal is signed. Customer agrees that it has read the Terms prior to customer's acceptance of this proposal. MCA hereby reserves the right to amend the Terms from time to time and without notice to Customer. This Agreement shall not be binding to MCA unless approved in writing by an Authorized Signer of MCA. In the event of non- approval, the sole liability of MCA shall be to refund to buyer the deposit amount that has been paid to MCA by Customer.

Agree to MCA's Terms

Agree to Other Terms: _____

MCA Location

Mobile Communications
America, Inc.
1330 Piedmont Ave
Troy MI 48083
(248) 997-4010
United States

Delivery Address

Administration Dave Dziedzic
Midland Public Schools
600 E Carpenter
Midland MI 48640
(989) 923-5088
United States

Billing Address

accountspayable@midlandps.org
Midland Public Schools
600 E Carpenter
Midland MI 48640
(989) 923-5088
United States

Seller

MCA Representative

Title

Approved MCA Authorized Signer

Customer

Printed Name

Title

Signature Authorized Signer

Date

9. 6. For Action: Gifts Totaling \$25,092.00 (Wamack)

Recommendation

School	Donor	Purpose	Amount
Dow High	HH Dow High Sports Boosters	Installation of 8 Electrical Circuits	\$9,842.00
Dow High	HH Dow High Sports Boosters	Installation of Daktronics Equipment	\$9,250.00
Midland High/Dow High	Dodrothy O Minikel Business Education Endowment Fund	BPA/DECA	\$6,000.00

Supporting Documents



[_Gift Summary April 2026](#)

4/20/2026	Dow High	522	H H Dow High Sports Boosters	Installation of 8 Electrical Circuits	9,842.00
4/20/2026	Dow High	521	H H Dow High Sports Boosters	Installation of Daktronics Equipment	9,250.00
4/20/2026	Midland & Dow High	28886	Dorothy O Minikel Business Education Endowment Fund	BPA & DECA	6,000.00
4/20/2026	Dow High	523	H H Dow High Sports Boosters	Rebounder for Boys and Girls Lacrosse	3,851.50
4/20/2026	Midland High	22 Checks	Midland High Baseball Parents	Support for MH Baseball Team Needs	2,440.00
4/20/2026	Dow High	2518	Megan Yezak	DHS Drama Spring Musical	2,000.00
4/20/2026	Midland High	ACH	Gerstacker Innovator Mini-Grant	Support TKO Transportation	2,000.00
4/20/2026	Adams	1770	Michigan Foundation for Agriculture	Backpack Buddy Program - Nutritional Resources	2,000.00
4/20/2026	Midland High	121645	Swan Valley School District	Transportation to BPA Nationals	1,961.80
4/20/2026	Jefferson	ACH	Gerstacker Innovator Mini-Grant	Support for Silent Sustained Reading Program	1,550.00
4/20/2026	Midland High	17047	Tuscola Technology Center	Transportation to BPA Nationals	1,038.60
4/20/2026	Midland High	279575	Sam Bernstein Law Firm	MHS Hockey	1,000.00
4/20/2026	Jefferson	28872	Hemlock Semiconductor	TechnoHuskies Team 10309	1,000.00
4/20/2026	Jefferson	28899	CommunityGives Youth Service Program	CyDogs FTC 10615	1,000.00
4/20/2026	Jefferson	28899	CommunityGives Youth Service Program	TechnoHuskies Team 10309	1,000.00
4/20/2026	Jefferson	736	Velazco Grill LLC	CyDogs Team 10615	500.00
4/20/2026	Central Park	28899	Kellogg Youth Fund	Beyond the Brick Safe Artifact Transportation	500.00
4/20/2026	Siebert	28899	Kellogg Youth Fund	Kindergarten Trip to the Zoo	500.00
4/20/2026	Adams	2082289	Midland Kiwanis Foundation	Mrs Richards Kindergarten Classroom	498.45
4/20/2026	Adams	101051	America Heart Association	Support for Adams Physical Education Program	300.00
4/20/2026	Jefferson	1164	Jefferson Parent Advisory Committee	Art Club Field Trip to Detroit Institute of Art	300.00
4/20/2026	Plymouth	1363	Donald Pearson	In Memory of Jean Pearson	200.00
4/20/2026	Midland High	68524,67854 & 70705	Ludus Technologies Inc.	Orchestra, Band & Choir	150.02
4/20/2026	Dow High	68524,67854 & 70705	Ludus Technologies Inc.	Band, Orchestra & Choir	150.02
4/20/2026	Central Park	1029	Meki & Ian Craig	Central Park Robotics	100.00

4/20/2026	Midland High	ACH	Dow Inc Political Action Committee	Robotics	65.00
4/20/2026	Jefferson	6036	Gavin & Lindsey McMacken	TechnoHuskies Team 10309	50.00
4/20/2026	Dow High	2050	Dow Parent Advisory Committee	Go Green, Drama & DECA	40.00
4/20/2026	Dow High	2993904	Cargill	FRC Team 2619	6.00
4/20/2026	Dow High	3000567	Cargill	FRC Team 2619	4.00
4/20/2026	Dow High	2993903	Cargill	FRC Team 2619	3.00
4/20/2026	Dow High	3000566	Cargill	FRC Team 2619	2.00

9. 7. For Information: Gifts totaling \$24,210.39 (Wamack) 

Recommendation

School	Donor	Purpose	Amount
Dow High	HH Dow High Sports Boosters	Rebounder for Boys and Girls Lacrosse	\$3,851.50
Midland High	Midland High Baseball Parents	Support for MH Baseball Team Needs	\$2,440.00
Dow High	Megan Yezak	DHS Drama Spring Musical	\$2,000.00
Midland High	Gerstacker Innovator Mini-Grant	Support TKO Transportation	\$2,000.00
Adams	Michigan Foundation for Agriculture	Backpack Buddy Program - Nutritional Resources	\$2,000.00
Midland High	Swan Valley School District	Transportation to BPA Nationals	\$1,961.80
Jefferson	Gerstacker Innovator Mini-Grant	Support for Silent Sustained Reading Program	\$1,550.00
Midland High	Tuscola Technology Center	Transportation to BPA Nationals	\$1,038.60
Midland High	Sam Bernstein Law Firm	MHS Hockey	\$1,000.00
Jefferson	Hemlock Semiconductor	TechnoHuskies Team 10309	\$1,000.00
Jefferson	CommunityGives Youth Service Program	CyDogs FTC 10615	\$1,000.00
Jefferson	CommunityGives Youth Service Program	TechnoHuskies Team 10309	\$1,000.00
Jefferson	Velazco Grill LLC	CyDogs Team 10615	\$500.00
Central Park	Kellogg Youth Fund	Beyond the Brick Safe Artifact Transportation	\$500.00
Siebert	Kellogg Youth Fund	Kindergarten Trip to the Zoo	\$500.00
Adams	Midland Kiwanis Foundation	Mrs. Richards Kindergarten Classroom	\$498.45
Adams	American Heart Association	Support for Adams Physical Education Program	\$300.00
Jefferson	Jefferson Parent Advisory Committee	Art Club Field Trip to Detroit Institute of Art	\$300.00
Plymouth	Donald Pearson	In Memory of Jean Pearson	\$200.00
Midland High	Ludus Technologies Inc.	Orchestra, Band & Choir	\$150.02
Dow High	Ludus Technologies Inc.	Orchestra, Band & Choir	\$150.02
Central Park	Meki & Ian Craig	Central Park Robotics	\$100.00
Midland High	Dow Inc Political Action Committee	Robotics	\$65.00

Jefferson	Gavin & Lindsey McMacken	TechnoHuskies Team 10309	\$50.00
Dow High	Dow Parent Advisory Committee	Go Green, Drama & DECA	\$40.00
Dow High	Charities Aid Foundation America	FRC Team 2619	\$6.00
Dow High	Charities Aid Foundation America	FRC Team 2619	\$4.00
Dow High	Charities Aid Foundation America	FRC Team 2619	\$3.00
Dow High	Charities Aid Foundation America	FRC Team 2619	\$2.00

Supporting Documents



[_Gift Summary April 2026](#)

4/20/2026	Dow High	522	H H Dow High Sports Boosters	Installation of 8 Electrical Circuits	9,842.00
4/20/2026	Dow High	521	H H Dow High Sports Boosters	Installation of Daktronics Equipment	9,250.00
4/20/2026	Midland & Dow High	28886	Dorothy O Minikel Business Education Endowment Fund	BPA & DECA	6,000.00
4/20/2026	Dow High	523	H H Dow High Sports Boosters	Rebounder for Boys and Girls Lacrosse	3,851.50
4/20/2026	Midland High	22 Checks	Midland High Baseball Parents	Support for MH Baseball Team Needs	2,440.00
4/20/2026	Dow High	2518	Megan Yezak	DHS Drama Spring Musical	2,000.00
4/20/2026	Midland High	ACH	Gerstacker Innovator Mini-Grant	Support TKO Transportation	2,000.00
4/20/2026	Adams	1770	Michigan Foundation for Agriculture	Backpack Buddy Program - Nutritional Resources	2,000.00
4/20/2026	Midland High	121645	Swan Valley School District	Transportation to BPA Nationals	1,961.80
4/20/2026	Jefferson	ACH	Gerstacker Innovator Mini-Grant	Support for Silent Sustained Reading Program	1,550.00
4/20/2026	Midland High	17047	Tuscola Technology Center	Transportation to BPA Nationals	1,038.60
4/20/2026	Midland High	279575	Sam Bernstein Law Firm	MHS Hockey	1,000.00
4/20/2026	Jefferson	28872	Hemlock Semiconductor	TechnoHuskies Team 10309	1,000.00
4/20/2026	Jefferson	28899	CommunityGives Youth Service Program	CyDogs FTC 10615	1,000.00
4/20/2026	Jefferson	28899	CommunityGives Youth Service Program	TechnoHuskies Team 10309	1,000.00
4/20/2026	Jefferson	736	Velazco Grill LLC	CyDogs Team 10615	500.00
4/20/2026	Central Park	28899	Kellogg Youth Fund	Beyond the Brick Safe Artifact Transportation	500.00
4/20/2026	Siebert	28899	Kellogg Youth Fund	Kindergarten Trip to the Zoo	500.00
4/20/2026	Adams	2082289	Midland Kiwanis Foundation	Mrs Richards Kindergarten Classroom	498.45
4/20/2026	Adams	101051	America Heart Association	Support for Adams Physical Education Program	300.00
4/20/2026	Jefferson	1164	Jefferson Parent Advisory Committee	Art Club Field Trip to Detroit Institute of Art	300.00
4/20/2026	Plymouth	1363	Donald Pearson	In Memory of Jean Pearson	200.00
4/20/2026	Midland High	68524,67854 & 70705	Ludus Technologies Inc.	Orchestra, Band & Choir	150.02
4/20/2026	Dow High	68524,67854 & 70705	Ludus Technologies Inc.	Band, Orchestra & Choir	150.02
4/20/2026	Central Park	1029	Meki & Ian Craig	Central Park Robotics	100.00

4/20/2026	Midland High	ACH	Dow Inc Political Action Committee	Robotics	65.00
4/20/2026	Jefferson	6036	Gavin & Lindsey McMacken	TechnoHuskies Team 10309	50.00
4/20/2026	Dow High	2050	Dow Parent Advisory Committee	Go Green, Drama & DECA	40.00
4/20/2026	Dow High	2993904	Cargill	FRC Team 2619	6.00
4/20/2026	Dow High	3000567	Cargill	FRC Team 2619	4.00
4/20/2026	Dow High	2993903	Cargill	FRC Team 2619	3.00
4/20/2026	Dow High	3000566	Cargill	FRC Team 2619	2.00

9. 8. For Information: Gifts of Item

Recommendation

School	Donor	Item(s)	Estimated Value
Midland High	Lee Industrial Contracting	Welding supplies: 8-pipe caps, 12-90s, 8-Ts, 6-12' sticks of black pipe, 6-ball valves (all Sch 40 black iron pipe)	\$2,000.00
Midland High	BOSTONtec	Sheet metal, hardware, and casters for Mobile Quench Tank	\$4,952.00

Supporting Documents

 [_Gift of Item April 2026 \(2\)](#)

 [_Gift of item April 2026](#)



Series 3000: Operations, Finance, and Property

3300 Facilities, Real, and Personal Property

3303-F Gifts and Donations Form

The Board of Education recognizes and appreciates the generosity and support it receives from individuals, companies, parent/guardian support groups, the community, and other donors ("Donors").

The District is a tax-exempt organization that may receive charitable contributions under Internal Revenue Service (IRS) Code Section 170(c)(1). The District may not be a tax-exempt organization under Section 501(c)(3). For additional information on deductions related to a donation ("Donation") or charitable contribution, Donors are encouraged to consult with a tax professional. Donations to the District shall be treated as public funds to be used for a public and educational purpose in accordance with state and federal law.

Donor Information

Name of Donor: Bostentec, Inc

Contact Person: Luke Richard

Address: 2700 James Savage Rd, Midland, MI 48642

Phone: (989) 496-3500 Email: luke.richard@coacsystems.com

If the Donor is an internal support group (Booster Club, PTO, Other Support Group) operating within the District as described under Policy 3106, please provide the following information, if applicable:

Describe student group or club, activity, or event:

N/A

Donation Information

School building associated with Donation: Midland High School

Insert "district-wide" if not associated with a particular school building.

Donation Purpose

Is the gift or donation for a specific purpose? Yes No

If yes, please describe the specific purpose (e.g., the District building, event or student club) as well as any other related details:

Weld skill development and the creation of a new
ouch tank for the welding program

Is the Donation for the purchase of a gift or an award for recognition (e.g., volunteer services, student achievement, staff appreciation)? Yes No

If yes, please describe the purpose: M/A

Do any other terms, conditions, or restrictions apply to the Donation? Yes No

If yes, please describe: The items donated are for the creation of a new ouch tank for the welding program, as well as, skill development.

By signing this form, I understand and agree that:

The information provided is complete and accurate to the best of my knowledge and belief. I acknowledge that I have read and understand Board Policy 3303, Gifts and Donations, and understand that accepted Donations become public funds of the District unless a specific exception applies under law.

Signature Gift Requester: Christopher Lee Wall Date: 4/14/26

Printed Name: Christopher Lee Wall

Title/Position & Building/Dept.: Welding Instructor, MHS, CTE Dept.

Signature Building/Dept Administrator: [Signature] Date: 4-14-26

For Internal Use

Accepted Not Accepted Date: 4/15/26

Signature of Superintendent or Designee: [Signature]

If BOE approval needed, date of meeting gift approved: _____

**Date: 4/14/2026**

DONATION FORM

To:

Midland High School – Welding Program
 Midland Public Schools
 600 E Carpenter St
 Midland, MI, 48640

From:

BOSTONtec
 2700 James Savage Rd.
 Midland, MI 48642

Description of Work / Product

ITEMS		Total
QTY	DESCRIPTION	\$4952.00
1	60Lx34Wx36T Mobile Quench Tank 304 SS <ul style="list-style-type: none"> ▪ 5in HD Steel Casters ▪ 2 Hanger Baskets 304 SS ▪ 3 Panel Grate System 304 SS ▪ 2in SS Fittings ▪ 400lbs 14ga Sheet Welding Material 	

Total Value of Donation: \$4952.00

No payment required – donated item*THANK YOU for your Business*



Series 3000: Operations, Finance, and Property

3300 Facilities, Real, and Personal Property

3303-F Gifts and Donations Form

The Board of Education recognizes and appreciates the generosity and support it receives from individuals, companies, parent/guardian support groups, the community, and other donors (“Donors”).

The District is a tax-exempt organization that may receive charitable contributions under Internal Revenue Service (IRS) Code Section 170(c)(1). The District may not be a tax-exempt organization under Section 501(c)(3). For additional information on deductions related to a donation (“Donation”) or charitable contribution, Donors are encouraged to consult with a tax professional. Donations to the District shall be treated as public funds to be used for a public and educational purpose in accordance with state and federal law.

Donor Information

Name of Donor: Lee Industrial Contracting

Contact Person: Dana Drew

Address: 631 Cesar E. Chavez, Pontiac, MI 48342

Phone: 248-332-4646 Email: danadrew@leecontracting.com

If the Donor is an internal support group (*Booster Club, PTO, Other Support Group*) operating within the District as described under Policy 3106, please provide the following information, if applicable:

Describe student group or club, activity, or event:

Donation Information

School building associated with Donation: Midland High School

Insert “district-wide” if not associated with a particular school building.

3303-F Gifts and Donations Form

Please indicate type of Donation and complete the appropriate section that follows.

- Monetary Donation [Account #: _____ - _____ - _____ - _____ - _____ - _____]
- Real Property
- Personal Property (e.g., equipment, supplies)
- Other (e.g., services, capital projects, or other construction):

Cash or Monetary Donation:

Amount of Donation: \$ _____

Do not attach checks to this Form. The District will provide notification of acceptance or, if unable to accept, notification including the reason for non-acceptance.

Personal Property:

Please include the item being donated, make/model, serial number, building where gift will be housed.

Description of Personal Property: (8) pipe caps, (12) 90s, (8) Ts,
(6) 12' sticks of black pipe, (6) ball valves-all material is for 1" Sch 40 black iron pipe
to be used in the Welding program.

Estimated fair market value: * \$ 2,000.00

Real Property and Capital Projects:

Description of Real Property: _____

Estimated fair market value: * \$ _____

Pursuant to Policy 3303, donations of real property require approval by the Board of Education. The Superintendent or designee will contact Donors desiring to gift real property or complete capital projects for additional documentation as identified in Policy 3303.

Other:

Description: _____

* For specific information related to valuation, see IRS Publication 561, *Determining the Value of Donated Property*.

Donation Purpose

Is the gift or donation for a specific purpose? Yes No

If yes, please describe the specific purpose (e.g., the District building, event or student club) as well as any other related details:

Welding Program

Is the Donation for the purchase of a gift or an award for recognition (e.g., volunteer services, student achievement, staff appreciation)? Yes No

If yes, please describe the purpose:

Do any other terms, conditions, or restrictions apply to the Donation? Yes No

If yes, please describe:

By signing this form, I understand and agree that:

The information provided is complete and accurate to the best of my knowledge and belief. I acknowledge that I have read and understand Board Policy 3303, Gifts and Donations, and understand that accepted Donations become public funds of the District unless a specific exception applies under law.

Signature

Gift Requester: Voluntary Donation

Date: 3/26/26

Printed Name:

Title/Position & Building/Dept.:

Signature

Building/Dept

Administrator:

Date:

For Internal Use

Accepted Not Accepted

Date: 4/10/24

Signature of Superintendent or Designee:

[Handwritten Signature]

If BOE approval needed, date of meeting gift approved:

10. Human Resources

Recommendation

Study Committee Chair: Member Horowitz; Staff Resource Person: Associate Superintendent Stark

10. 1. For Information: The Board and Staff extend their deepest sympathy to the following family: (Stark) 

Recommendation

The Board and Staff extend their deepest sympathy to the family of Beth Chapman, who passed away on April 5, 2026. Beth was employed as a paraprofessional in various locations throughout the district until her retirement in 2017, with 28 years of service. Following her retirement, she also served as a substitute paraprofessional from 2017-2019.

Supporting Documents



[B. Chapman obituary](#)

11. Correspondence From the Board of Education

11. 1. Letters from the Board of Education to:

Recommendation

- Gerstacker Foundation c/o Midland County ESA
- Ludus Technologies, Inc.
- H.H. Dow High Sports Boosters (2)
- Firehouse Subs - K&S Brothers, LLC
- The Music Parents of Northeast
- Apprecots
- Joseph & Angelin Nokku
- Todd & Mary Draves Family Donor Advised Fund (2)
- Julie Johnston & Angela Kerr
- Jefferson Music Parents

Supporting Documents



[_Gift letters sent 3.17.26](#)



Midland Public Schools

Inspiring Excellence

600 E. Carpenter Street
Midland, MI 48640
Website: midlandps.org
Phone: 989-923-5001

Board of Education

March 17, 2026

Gerstacker Foundation c/o Midland County ESA
3917 Jefferson Avenue
Midland, MI 48640

Dear Gerstacker Foundation,

The Board of Education wishes to thank you for the generous gift presented at the Board meeting on March 16, 2026. Your gift has been accepted with our most sincere gratitude.

AMOUNT:	\$5,000.00
CHECK DATE:	
CHECK NUMBER:	ACH

Thank you, Gerstacker Foundation, for your support of Midland Public Schools students, staff, and families. Your generosity will have a lasting influence.

Sincerely,



Jennifer Ringgold, Secretary
cc: Members of the Board of Education

Phillip Rausch, President

Scott McFarland, Vice President

Jennifer Ringgold, Secretary

Jon Lauderbach, Treasurer

Brad Blasy, Trustee

Ann Horowitz, Trustee

Meki Craig, Trustee

Penny Miller-Nelson, Superintendent



Midland Public Schools
Inspiring Excellence

600 E. Carpenter Street
Midland, MI 48640
Website: midlandps.org
Phone: 989-923-5001

Board of Education

March 17, 2026

Ludus Technologies, Inc.
217 E 24th St #140
Holland, MI 49423

Dear Ludus Technologies, Inc.,

The Board of Education wishes to thank you for the generous gift that was presented to the Board of Education at the March 16, 2026, meeting. Your gift has been accepted with our most sincere gratitude.

AMOUNT:	\$105.44
CHECK DATE:	02/02/2026
CHECK NUMBER:	068041

Thank you, Ludus Technologies, Inc., for your support of Midland Public Schools students, staff, and families. Your generosity will have a lasting influence.

Sincerely,

Jennifer Ringgold, Secretary
cc: Members of the Board of Education

Phillip Rausch, President

Scott McFarland, Vice President

Jennifer Ringgold, Secretary

Jon Lauderbach, Treasurer

Brad Blasy, Trustee

Ann Horowitz, Trustee

Meki Craig, Trustee

Penny Miller-Nelson, Superintendent



Midland Public Schools
Inspiring Excellence

600 E. Carpenter Street
Midland, MI 48640
Website: midlandps.org
Phone: 989-923-5001

Board of Education

March 17, 2026

HH Dow High Sports Boosters
3901 N Saginaw Rd
Midland, MI 48640

Dear HH Dow High Sports Boosters,

The Board of Education wishes to thank you for the generous gift presented at the Board meeting on March 16, 2026. Your gift has been accepted with our most sincere gratitude.

AMOUNT:	\$1,000.00
CHECK DATE:	02/12/2026
CHECK NUMBER:	517

Thank you, HH Dow High Sports Boosters, for your support of Midland Public Schools students, staff, and families. Your generosity will have a lasting influence.

Sincerely,

Jennifer Ringgold, Secretary
cc: Members of the Board of Education

Phillip Rausch, President

Scott McFarland, Vice President

Jennifer Ringgold, Secretary

Jon Lauderbach, Treasurer

Brad Blasy, Trustee

Ann Horowitz, Trustee

Meki Craig, Trustee

Penny Miller-Nelson, Superintendent



Midland Public Schools

Inspiring Excellence

600 E. Carpenter Street
Midland, MI 48640
Website: midlandps.org
Phone: 989-923-5001

Board of Education

March 17, 2026

Firehouse Subs - K&S Brothers, LLC
% Sean Hoffman
7215 Eastman Ave
Midland, MI 48642

Dear Firehouse Subs - K&S Brothers, LLC,

The Board of Education wishes to thank you for the generous gift presented at the Board meeting on March 16, 2026. Your gift has been accepted with our most sincere gratitude.

AMOUNT:	\$200.00
CHECK DATE:	01/29/2026
CHECK NUMBER:	2357

Thank you, Firehouse Subs - K&S Brothers, LLC, for your support of Midland Public Schools students, staff, and families. Your generosity will have a lasting influence.

Sincerely,

Jennifer Ringgold, Secretary
cc: Members of the Board of Education

Phillip Rausch, President

Scott McFarland, Vice President

Jennifer Ringgold, Secretary

Jon Lauderbach, Treasurer

Brad Blasy, Trustee

Ann Horowitz, Trustee

Meki Craig, Trustee

Penny Miller-Nelson, Superintendent



Midland Public Schools
Inspiring Excellence

600 E. Carpenter Street
Midland, MI 48640
Website: midlandps.org
Phone: 989-923-5001

Board of Education

March 17, 2026

The Music Parents of Northeast
% Jessica Burdick

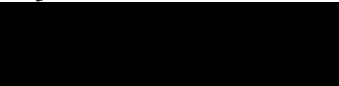

Dear The Music Parents of Northeast,

The Board of Education wishes to thank you for the generous gift presented at the Board meeting on March 16, 2026. Your gift has been accepted with our most sincere gratitude.

AMOUNT:	\$266.00
CHECK DATE:	02/13/2026
CHECK NUMBER:	1098

Thank you, The Music Parents of Northeast, for your support of Midland Public Schools students, staff, and families. Your generosity will have a lasting influence.

Sincerely,

Jennifer Ringgold, Secretary
cc: Members of the Board of Education

Phillip Rausch, President

Scott McFarland, Vice President

Jennifer Ringgold, Secretary

Jon Lauderbach, Treasurer

Brad Blasy, Trustee

Ann Horowitz, Trustee

Meki Craig, Trustee

Penny Miller-Nelson, Superintendent



Midland Public Schools
Inspiring Excellence

600 E. Carpenter Street
Midland, MI 48640
Website: midlandps.org
Phone: 989-923-5001

Board of Education

March 17, 2026

Apprecots
340 S. Main St
Freeland, MI 48623

Dear Apprecots,

The Board of Education wishes to thank you for the generous gift presented at the Board meeting on March 16, 2026. Your gift has been accepted with our most sincere gratitude.

AMOUNT:	\$300.00
CHECK DATE:	01/21/2026
CHECK NUMBER:	697

Thank you, Apprecots, for your support of Midland Public Schools students, staff, and families. Your generosity will have a lasting influence.

Sincerely,

Jennifer Ringgold, Secretary
cc: Members of the Board of Education

Phillip Rausch, President

Scott McFarland, Vice President

Jennifer Ringgold, Secretary

Jon Lauderbach, Treasurer

Brad Blasy, Trustee

Ann Horowitz, Trustee

Meki Craig, Trustee

Penny Miller-Nelson, Superintendent



Midland Public Schools

Inspiring Excellence

600 E. Carpenter Street
Midland, MI 48640
Website: midlandps.org
Phone: 989-923-5001

Board of Education

March 17, 2026

Joseph & Angelin Nokku
[REDACTED]

Dear Joseph & Angelin Nokku,

The Board of Education wishes to thank you for the generous gift presented at the Board meeting on March 16, 2026. Your gift has been accepted with our most sincere gratitude.

AMOUNT:	\$1,000.00
CHECK DATE:	02/11/2026
CHECK NUMBER:	940

Thank you, Joseph & Angelin Nokku, for your support of Midland Public Schools students, staff, and families. Your generosity will have a lasting influence.

Sincerely,

Jennifer Ringgold, Secretary
cc: Members of the Board of Education

Phillip Rausch, President

Scott McFarland, Vice President

Jennifer Ringgold, Secretary

Jon Lauderbach, Treasurer

Brad Blasy, Trustee

Ann Horowitz, Trustee

Meki Craig, Trustee

Penny Miller-Nelson, Superintendent



Midland Public Schools

Inspiring Excellence

600 E. Carpenter Street
Midland, MI 48640
Website: midlandps.org
Phone: 989-923-5001

Board of Education

March 17, 2026

Todd and Mary Draves Family Donor Advised Fund
% Mary Draves



Dear Todd and Mary Draves Family Donor Advised Fund,

The Board of Education wishes to thank you for the generous gift presented at the Board meeting on March 16, 2026. Your gift has been accepted with our most sincere gratitude.

AMOUNT:	\$1,000.00
CHECK DATE:	02/19/2026
CHECK NUMBER:	04069522

Thank you, Todd and Mary Draves Family Donor Advised Fund, for your support of Midland Public Schools students, staff, and families. Your generosity will have a lasting influence.

Sincerely,

Jennifer Ringgold, Secretary
cc: Members of the Board of Education

Phillip Rausch, President

Scott McFarland, Vice President

Jennifer Ringgold, Secretary

Jon Lauderbach, Treasurer

Brad Blasy, Trustee

Ann Horowitz, Trustee

Meki Craig, Trustee

Penny Miller-Nelson, Superintendent



Midland Public Schools

Inspiring Excellence

600 E. Carpenter Street
Midland, MI 48640
Website: midlandps.org
Phone: 989-923-5001

Board of Education

March 17, 2026

Julie Johnston & Angela Kerr

Dear Julie Johnston & Angela Kerr,

The Board of Education wishes to thank you for the generous gift presented at the Board meeting on March 16, 2026. Your gift has been accepted with our most sincere gratitude.

AMOUNT:	\$1,000.00
CHECK DATE:	02/19/2026
CHECK NUMBER:	1379

Thank you, Julie Johnston & Angela Kerr, for your support of Midland Public Schools students, staff, and families. Your generosity will have a lasting influence.

Sincerely,

Jennifer Ringgold, Secretary
cc: Members of the Board of Education

Phillip Rausch, President

Scott McFarland, Vice President

Jennifer Ringgold, Secretary

Jon Lauderbach, Treasurer

Brad Blasy, Trustee

Ann Horowitz, Trustee

Meki Craig, Trustee

Penny Miller-Nelson, Superintendent



Midland Public Schools
Inspiring Excellence

600 E. Carpenter Street
Midland, MI 48640
Website: midlandps.org
Phone: 989-923-5001

Board of Education

March 17, 2026

Jefferson Music Parents
% Kevin Schroeder

Dear Jefferson Music Parents,

The Board of Education wishes to thank you for the generous gift presented at the Board meeting on March 16, 2026. Your gift has been accepted with our most sincere gratitude.

AMOUNT:	\$2,000.00
CHECK DATE:	02/12/2026
CHECK NUMBER:	1177

Thank you, Jefferson Music Parents, for your support of Midland Public Schools students, staff, and families. Your generosity will have a lasting influence.

Sincerely,

Jennifer Ringgold, Secretary
cc: Members of the Board of Education

Phillip Rausch, President

Scott McFarland, Vice President

Jennifer Ringgold, Secretary

Jon Lauderbach, Treasurer

Brad Blasy, Trustee

Ann Horowitz, Trustee

Meki Craig, Trustee

Penny Miller-Nelson, Superintendent



Midland Public Schools

Inspiring Excellence

600 E. Carpenter Street
Midland, MI 48640
Website: midlandps.org
Phone: 989-923-5001

Board of Education

March 17, 2026

Todd and Mary Draves Family Donor Advised Fund
% Mary Draves

Dear Todd and Mary Draves Family Donor Advised Fund,

The Board of Education wishes to thank you for the generous gift presented at the Board meeting on March 16, 2026. Your gift has been accepted with our most sincere gratitude.

AMOUNT:	\$2,000.00
CHECK DATE:	02/11/2026
CHECK NUMBER:	04069185

Thank you, Todd and Mary Draves Family Donor Advised Fund, for your support of Midland Public Schools students, staff, and families. Your generosity will have a lasting influence.

Sincerely,

Jennifer Ringgold, Secretary
cc: Members of the Board of Education

Phillip Rausch, President

Scott McFarland, Vice President

Jennifer Ringgold, Secretary

Jon Lauderbach, Treasurer

Brad Blasy, Trustee

Ann Horowitz, Trustee

Meki Craig, Trustee

Penny Miller-Nelson, Superintendent



Midland Public Schools
Inspiring Excellence

600 E. Carpenter Street
Midland, MI 48640
Website: midlandps.org
Phone: 989-923-5001

Board of Education

March 17, 2026

HH Dow High Sports Boosters
3901 N Saginaw Rd
Midland, MI 48640

Dear HH Dow High Sports Boosters,

The Board of Education wishes to thank you for the generous gift presented at the Board meeting on March 16, 2026. Your gift has been accepted with our most sincere gratitude.

AMOUNT:	\$5,445.00
CHECK DATE:	02/12/2026
CHECK NUMBER:	518

Thank you, HH Dow High Sports Boosters, for your support of Midland Public Schools students, staff, and families. Your generosity will have a lasting influence.

Sincerely,

Jennifer Ringgold, Secretary
cc: Members of the Board of Education

Phillip Rausch, President

Scott McFarland, Vice President

Jennifer Ringgold, Secretary

Jon Lauderbach, Treasurer

Brad Blasy, Trustee

Ann Horowitz, Trustee

Meki Craig, Trustee

Penny Miller-Nelson, Superintendent

12. Scheduled Activities: For Information

Recommendation

All meetings are Regular and Special Meetings of the Board of Education and begin at 7:00 p.m. at the MPS Administration Center (600 E. Carpenter, Midland) unless otherwise noted:

- May 18, 2026
- June 15, 2026
- July 20, 2026
- August 17, 2026
- September 21, 2026
- October 19, 2026
- November 16, 2026
- December 21, 2026

13. Study Session Discussion

Summary

This portion of the agenda is utilized by the Board to introduce topics for future study, to discuss school district related matters, to complete professional association business and to relate items of interest. No action is taken during this time. Occasionally closed sessions are scheduled to discuss confidential personnel, negotiations or property matters.

13. 1. Points of Clarification

13. 2. Announcements from Superintendent Miller-Nelson

14. Adjournment
